



DUDLEY ANNE LIBRARY  
NAVAL POST GRADUATE SCHOOL  
MONTEREY CALIF 93940









# NAVAL POSTGRADUATE SCHOOL

## Monterey, California

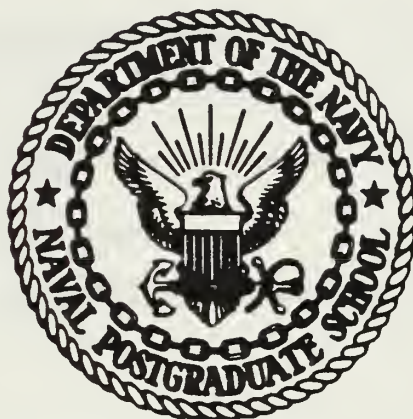

# THESIS

COMPUTER EVALUATION OF THE ON-AND-OFF-DESIGN  
PERFORMANCE OF AN AXIAL AIR TURBINE

by

Robert Cirone

March 1981

Thesis Advisor

R. P. Shreeve

Approved for public release; distribution unlimited

T199164

THE UNIVERSITY OF CHICAGO  
LIBRARY



1911





REPORT DOCUMENTATION PAGE		READ INSTRUCTIONS BEFORE COMPLETING FORM
1. REPORT NUMBER	2. GOVT ACCESSION NO.	3. RECIPIENT'S CATALOG NUMBER
4. TITLE (and Subtitle) Computer Evaluation of the On-and-Off Design Performance of an Axial Air Turbine		5. TYPE OF REPORT & PERIOD COVERED Master's Thesis March 1981
7. AUTHOR(s) Robert Cirone		6. PERFORMING ORG. REPORT NUMBER
9. PERFORMING ORGANIZATION NAME AND ADDRESS Naval Postgraduate School Monterey, California 93940		8. CONTRACT OR GRANT NUMBER(s)
11. CONTROLLING OFFICE NAME AND ADDRESS Naval Postgraduate School Monterey, California 93940		10. PROGRAM ELEMENT, PROJECT, TASK AREA & WORK UNIT NUMBERS
14. MONITORING AGENCY NAME & ADDRESS (if different from Controlling Office)		12. REPORT DATE March 1981
		13. NUMBER OF PAGES 268
		18. SECURITY CLASS. (of this report)  Unclassified
		18a. DECLASSIFICATION/DOWNGRADING SCHEDULE
16. DISTRIBUTION STATEMENT (of this Report)  Approved for public release; distribution unlimited.		
17. DISTRIBUTION STATEMENT (of the abstract entered in Block 20, if different from Report)		
18. SUPPLEMENTARY NOTES		
19. KEY WORDS (Continue on reverse side if necessary and identify by block number)  Axial turbine Performance prediction Off-design performance		
20. ABSTRACT (Continue on reverse side if necessary and identify by block number)  An existing code for calculating axial turbine performance using multiple stream surfaces was modified and made to run on the equivalent of an HP-1000 computer system. Calculations were made for the geometry of a 485 horsepower dual-discharge air-drive turbine for both on and off-design conditions. The results were compared with available data obtained at off-design speeds. Agreement of the flow rate and horsepower to within 5% was obtained.		



Approved for public release; distribution unlimited

Computer Evaluation of the On-and-Off-Design  
Performance of an Axial Air Turbine

by

Robert Cirone  
Lieutenant, United States Navy  
B.S.M.E., University of Notre Dame, 1973

Submitted in partial fulfillment of the  
requirements for the degree of

MASTER OF SCIENCE IN MECHANICAL ENGINEERING

from the

NAVAL POSTGRADUATE SCHOOL  
March 1981



ABSTRACT

An existing code for calculating axial turbine performance using multiple stream surfaces was modified and made to run on the equivalent of an HP-1000 computer system. Calculations were made for the geometry of a 485 horsepower dual-discharge air-drive turbine for both on and off-design conditions. The results were compared with available data obtained at off-design speeds. Agreement of the flow rate and horsepower to within 5% was obtained.



TABLE OF CONTENTS

I.	INTRODUCTION -----	13
	A. DESCRIPTION OF THE TRANSONIC COMPRESSOR TEST RIG -----	13
	B. STATEMENT OF THE TASK -----	14
II.	APPROACH -----	16
	A. BACKGROUND -----	16
	B. ANALYSIS -----	17
	C. METHOD OF SOLUTION -----	19
	D. MODIFICATION TO THE COMPUTER CODE -----	20
III.	RESULTS OF AXIAL TURBINE PREDICTIONS -----	23
	A. USING BOTH COMPLETE AND MODIFIED PROGRAMS ---	23
	B. COMPARISON WITH MEASURED DATA -----	24
IV.	DISCUSSION -----	26
V.	CONCLUSIONS -----	28
APPENDIX A:	DESCRIPTION OF THE COMPUTER PROGRAM -----	42
	A-1. INTRODUCTION -----	42
	A-2. DESCRIPTION -----	42
	A-2.1 Input Data -----	42
	A-2.2 Initial Geometric Calculations -----	43
	A-2.3 Calculation of Gas Outlet Angles -----	43
	A-2.4 Calculation of the Flow Rate -----	44





A-2.5	Solution of the Equation of Motion for the Stator -----	45
A-2.6	Calculation of the Stator Loss Coefficients -----	49
A-2.7	Solution of the Continuity Equation -----	53
A-2.8	Calculation of the Rotor Inlet Conditions -----	56
A-2.9	Calculation of the Rotor Exit Conditions -----	58
A-2.10	Accounting for Streamline Curvature -----	61
APPENDIX B:	DERIVATION OF EQUATIONS USED IN THE PROGRAM -----	95
B-1.	EQUATION OF MOTION FOR RELATIVE FLOW -----	95
B-2.	EQUATION OF MOTION FOR ABSOLUTE FLOW -----	107
B-3.	THE AREA RESTRICTION FACTOR, Z -----	108
B-4.	THE ENERGY PARAMETER, H*** -----	112
APPENDIX C:	PROGRAM SEGMENTATION ON THE HP-1000 -----	115
APPENDIX D:	RUNNING THE COMPUTER PROGRAM -----	119
APPENDIX E:	DISCREPANCIES IN MACCHI'S PROGRAM -----	122
APPENDIX F:	COMPUTER OUTPUT -----	124
APPENDIX G:	COMPUTER CODE LISTING -----	240
LIST OF REFERENCES	-----	265
INITIAL DISTRIBUTION LIST	-----	267



## LIST OF TABLES

I	Turbine Geometry -----	30
II	Measured/Design Data Used to Verify the Program -----	31
III	Comparison of Predicted Turbine Performance vs Measured Performance -----	32
IV	Values of Assumed Total Inlet Temperature for Each Pressure Ratio -----	33
A-I	Turbine Geometric Input Data (STATOR) -----	69
A-II	Turbine Geometric Input Data (ROTOR) -----	71
A-III	Turbine Operating Conditions (INPUT DATA) ----	73
A-IV	Special Input Data -----	74
A-V	Program Control Parameters -----	75
A-VI	Fortran Symbols in the Main Program -----	76
A-VII	Fortran Symbols in Subroutine (CHAN) -----	78
A-VIII	Fortran Symbols in Subroutine (STATR) -----	79
A-IX	Fortran Symbols in Subroutine (TRAU2) -----	80
A-X	Fortran Symbols in Subroutine (FLOWR) -----	81
A-XI	Fortran Symbols in Subroutine (ROTO1) -----	82
A-XII	Fortran Symbols in Subroutine (ROTO2) -----	83



LIST OF FIGURES

1.	Schematic of the Compressor Test Rig, with proposed modifications -----	34
2.	Turbine rotor and stator blade shapes -----	35
3.	Predicted horsepower vs RPM as a function of pressure ratio, at temperatures to avoid condensation -----	36
4.	Predicted referred horsepower vs referred RPM as a function of pressure ratio -----	37
5.	Predicted flow rate vs RPM as a function of pressure ratio at temperatures to avoid condensation -----	38
6.	Predicted horsepower vs pressure ratio as a function of RPM, at temperatures to avoid condensation -----	39
7.	Predicted flow rate vs pressure ratio as a function of RPM at temperatures to avoid condensation -----	40
8.	Predicted referred flow rate vs referred RPM as function of pressure ratio -----	41
A-1	Program flowchart -----	84
A-2	Blade nomenclature -----	85
A-3	Velocity diagram nomenclature -----	86
A-4	Interconnection of the subroutines in the Traupel method -----	87
A-5	Initial profile loss coefficient and Mach number correction from Traupel -----	88
A-6	T.E. thickness correction factor, mixing loss coefficient and fan loss coefficient from Traupel-	89
A-7	"Remaining" loss coefficient from Traupel -----	90
A-8	Subroutine FLOWR flowchart -----	91



A-9	Subroutine ROTO2 flowchart -----	92
A-10	Tip leakage loss coefficient plot from Traupel -----	93
A-11	Streamline coordinates -----	94
B-1	Boundary layer effects at the exit of a blade row -----	114
C-1	Program segmentation.-Illustration of the main program calling a segment into logical memory -----	118





## LIST OF SYMBOLS

A	Cross sectional area
a	Blade opening
c	Blade chord
$c_p$	Specific heat at constant pressure
D	Diameter
E	Kinetic energy
$g_c$	Universal gravitational constant
H	Total enthalpy
H***	Energy parameter, boundary layer
h	Static enthalpy
h	Blade height
HP	Horsepower
I	Integrand
J	Conversion factor
$K_{is}$	Head coefficient
L	Distance between stations
M	Mach number
$\dot{m}$	Mass flow rate
m	Exponent used in boundary layer calculations
$\dot{m}_{ref}$	Reference flow rate
N	Rotational speed
P	Pressure (Psia )
R	Gas constant for air



R	Radius
r	Radius
r*	Theoretical degree of reaction
s	Entropy
s*	Non-dimensional entropy
T	Temperature ( $^{\circ}\text{R}$ )
t	Maximum blade thickness
$t_e$	Trailing edge thickness
U	Peripheral velocity
u	Velocity within the boundary layer
V	Absolute velocity
W	Relative velocity
X	Non-dimensional radius ( $r/r_m$ )
Y	Non-dimensional axial velocity ratio ( $V_a/V_{am}$ )
y	Pressure loss coefficient

#### GREEK LETTERS

$\alpha$	Absolute gas outlet angle
$\beta$	Relative gas outlet angle
$\gamma$	Specific heat ratio, $c_p/c_v$
$\delta$	Boundary layer thickness
$\delta$	Referred pressure ratio ( $P_{t0}/14.7$ )
$\delta^*$	Boundary layer displacement thickness
$\delta^{***}$	Boundary layer energy thickness
$\xi$	Loss coefficient
$\eta$	Efficiency



$\theta$	Referred temperature ratio, $\frac{T_{T0}}{518.4}$
$\kappa$	Curvature factor
$\lambda$	Angle of flow in a meridional plane
$\xi$	Area restriction factor
$\rho$	Density
$\Phi$	Non-dimensional flow function
$\omega$	Angular velocity

#### SUBSCRIPTS

a	Axial
ACT	Actual or computed value
E	An equivalent thermodynamic quantity
eff	Effective
H	Hub
is	Isentropic
m	Mean streamline value
p	Profile
R	Relative flow value
r	radial
ref	Referred value
req	Required
s	secondary
TH	Theoretical value
TO	Total conditions
u	Tangential
o	Station at the stator inlet



- 1 Station between the stator and the rotor
- 2 Station at the rotor outlet





## I. INTRODUCTION

### A. DESCRIPTION OF THE TRANSONIC COMPRESSOR TEST RIG

The Transonic Compressor Test Rig at the Turbopropulsion Laboratory (TPL) of the Naval Postgraduate School is shown schematically in Fig. 1 and consists of the following major components:

1. Air drive turbine.
2. Air supply system.
3. Associated piping including throttling valves at the turbine and compressor inlets.
4. Test compressor.

The drive turbine is a dual-flow axial air turbine with 50% reaction. The geometry is given in Table 1. The profile shapes of the turbine rotor and of the stator blades are identical and the blades are of constant section along the radius as shown in Fig. 2. The stator has 31 blades while the rotor has 32 (to avoid resonant excitation from wake interference). The two parallel stages of the turbine are designed for the following output and total inlet conditions:

Pressure Ratio: 2.8

Total Inlet Temperature: 640°R

Flow rate: 10.85 LBM/SEC

Horsepower: 485 HP



The compressor presently under test is a transonic single stage, axial flow compressor. It is instrumented for measurements of torque, mass flow rate, stagnation temperatures and pressures, case and hub wall pressures, and for unsteady pressure measurements in the flow field and at the walls.

The Air Supply System incorporates an electric motor-driven multi-stage axial flow compressor manufactured by Allis-Chalmers. It can presently supply up to 12 lbs/sec of air at 3 atmospheres, at temperatures between 560°R and 660°R. The compressor is rated at 1250 HP and has a controlled variable speed drive.

#### B. STATEMENT OF THE TASK

The Transonic Compressor Test Rig was designed to provide the means for obtaining experimental data in fundamental compressor phenomena. Following the present experiments, an experiment to investigate the onset of supersonic unstalled blade flutter is planned which would involve replacing at least the present compressor rotor by a rotating cascade of flat-plate blades. Such a rotor would not be able to produce the pressure ratios required to pump the required flow rates through the system. Therefore, it has been proposed, that a turbocharger compressor be fitted in series with the rotating cascade to provide the required flow through it. The turbocharger would also be driven using air from the Allis-Charmers air supply system.



In order to evaluate the feasibility of the turbocharger installation, it is necessary to determine the mass flow rate required by the drive turbine to drive the test compressor at a given power and speed. The remaining air to drive the turbocharger turbine is then known and the selection of a commercially available turbocharger suitable for this application can be made.

Thus, the performance of the air drive turbine must be known over the complete speed range. Of particular importance, are the required mass flow rates for given values of horsepower. The problem, therefore, is to obtain the turbine performance map for all pressure ratios and speeds.



## II. APPROACH

### A. BACKGROUND

A search of the most recent literature revealed a number of analytical methods for the calculation of turbine off-design performance. The majority of these used in a finite element approach but little information on the relative success of these methods in practice was available. Two alternate methods, both used at the Turbopropulsion Laboratory, were those of M. H. Vavra and E. Macchi. Each was examined in detail.

The method of Vavra, given in Ref. [1] is a one-dimensional (meanline) approach using mathematical modelling and experimental data to express flow angles and losses. It is primarily a method to design turbine blading but may also be used to predict turbine performance for a given set of gas inlet and operating conditions when the blading geometries are specified. It is assumed that the axial velocity is constant along the blading from hub to tip. Vavra states that this assumption is reasonable for blading in which the tip-to-hub ratio is equal to or less than 1.15. The ratio is 1.312 and 1.424 for the drive turbine stator and rotor blading respectively. It was thought therefore, that the method of Macchi might yield more accurate predictions.





Macchi's method is given in Ref. [2]. The method, implemented by Macchi in a computer program written for the IBM 360, was an extension of the work done by R. Eckert [Ref. 3] and R. Harrison [Ref. 4]. Eckert wrote a program, following a simplified three-dimensional analysis, which could be used to predict the performance of a single-stage axial flow turbine. Harrison improved the program by modifying the analysis to take into account streamline curvature. Both programs were based on the three-dimensional method developed by Vavra in Ref. [5]. Macchi's principle improvements to the program were to introduce the choice of various methods to calculate gas outlet angles and loss coefficients. Two methods of calculating gas outlet angles are included; those of Ainley and Mathieson [Ref. 6] and Traupel [Ref. 7]. Five methods for calculating the loss coefficients can be selected; those due to Ainley and Mathieson [Ref. 6], Dunham and Came [Ref. 8], Balje [Ref. 9], Lonherr and Carter [Ref. 10] and Traupel [Ref. 7].

Macchi's computer program, as documented in Ref. [2], was selected for performance predictions of the drive turbine. It should be noted that no card deck of the program was available, and no results of using the program were available other than those included in Ref. [2].

## B. ANALYSIS

The method requires the following assumptions;

1. There are an infinite number of blades in each blade row so that blades downstream do not affect upstream conditions.



2. The flow is axisymmetric at locations where the equation of motion is solved.

3. The flow is steady and adiabatic. Thus, the total enthalpy through the stator remains constant along a streamline and the relative total enthalpy through the rotor remains constant along a streamline.

4. All equations are solved at between blade row locations. Increases in entropy occur in the blade row upstream of the stations where equations are solved and the entropy change along a streamline between blade rows is zero.

5. The boundary layers on the turbine casing are not accounted for.

The method of solution is as follows:

1. Assume initial radial positions of the streamlines.

2. Obtain the axial velocity distribution by solving the equation of motion at the stator outlet. The velocity distribution into the stator is assumed to be axial, and uniform

3. Obtain stator loss coefficients.

4. Check overall continuity and adjust the inlet Mach number as necessary.

5. Check the between-streamline continuity, and adjust streamline radial positions as necessary.

6. Repeat this process for the rotor.

7. Re-cycle all the above calculations, accounting for streamline curvature, and repeat until convergence is reached.



### C. METHOD OF SOLUTION

The computer code written by Macchi was originally run on the IBM 360 computer. The program consisted of a deck of over 2000 program cards plus over 60 data cards. Since the deck could not be located, it was necessary to re-type the program from the listing in Macchi's paper. However, since the IBM 360 computer was soon to be replaced in the period in which the work was to be carried out, an alternate computer was sought.

The HP-1000 series mini-computer located at TPL was selected for two reasons. First, the machine used FORTRAN as did Macchi's program. Secondly, it would be a benefit to TPL to have the program immediately available on the laboratory computer.

The first steps were to analyze Macchi's program, in detail, and then to run it using his example input/output. In analyzing the program it became obvious that the computer program listing given in Ref. 2, was not the one used to obtain the listed output. Numerous discrepancies were found in the listing, some of which would have prevented the program from running; others would have caused incorrect results to be obtained. A listing of these discrepancies is contained in Appendix E. When the program was understood and flow-charted, it was keyed-in at the HP-1000 computer terminal. However, modifications were required to accomodate



the program within the mini-computer disc-based operating system.

#### D. MODIFICATION TO THE COMPUTER CODE

Since there was no card reader, variable input data such as turbine speed had to be entered using data or specification statements. This contributed in part to the most difficult problem, that of program size. The HP-1000 mini-computer uses a disc with a storage capability of 19.5 mega-bytes. However, the machine memory is only 124 K Bytes, of which only 29 K Bytes is available to a programmer. Also, the available memory is divided up, or partitioned into two 18 K and one 11 K partitions, so that no single program can exceed 18 K. It was estimated that Macchi's program was over 100 K. So it was clear that the program would have to be modified if it were to run on the mini-computer.

The first modification was to remove all subroutines from the program that were not actually used. It will be recalled that Macchi's program contained five methods for calculating loss coefficients and two methods for calculating gas outlet angles. It was decided that only the Traupel method of calculating loss coefficients would be retained. Traupel was selected for two reasons. Firstly, it was the method used by Macchi in his example calculations and therefore the modified program should still reproduce Macchi's results. Secondly, the method of Traupel is widely respected.





The method of calculating gas outlet angles was totally changed. Neither Ainley and Mathieson [Ref. 6] nor Traupel [Ref. 7] was used. Both methods required prohibitively large sections of computer code. The method selected was that of Vavra [Ref. 1].

Use of Vavra's method greatly simplified the program because this method predicts gas outlet angles independently of the inlet Mach number. Macchi's approach was to use Traupel's method which is dependent on the Mach number of the flow into the blade.

The above simplifications reduced the program size from 2257 lines to less than 1800 lines. However, this was still too large and the program could not be loaded without overflowing the memory.

The solution to the problem was found in program segmentation. In this process, the computer code is divided into a main program and several segments. Each segment is a "piece" of the original program. The segments are individually compiled and loaded. However, the segments are placed into memory only as they are needed to execute the overall program. Thus, a very large program can be made to run in the available 18 K partition. Since the present program was not originally intended for a mini-computer, segmentation was not straight forward. The method finally arrived at is detailed in Appendix C. Basically, the main



program consists of all the subroutines, while the three other segments contain coding which enables program flow to proceed in a logical manner.

Successfully segmented, the program was run using Macchi's input. An output was obtained which agreed almost exactly with Macchi's results. All output quantities were within 1% of Macchi's quantities. The differences were, in all probability, due to the different method of calculating gas outlet angles.

After verifying Macchi's program, the drive turbine geometry was input and the program was run for a given set of operating conditions. The results are discussed in the following section. Note: The "verification" of Macchi's program amounted to verifying that the computer code now loaded into the HP-1000, was indeed Macchi's code. It was not known whether Macchi's output data were a good or bad prediction of performance since they were not compared with test results.



### III. RESULTS OF AXIAL TURBINE PREDICTIONS

#### A. USING BOTH COMPLETE AND MODIFIED PROGRAMS

The drive turbine geometry was input and the following solution flow path was selected:

1. Stator and rotor loss coefficients were functions of pressure ratio.
2. The blockage factor,  $\xi^*$ , used in the equation of continuity was equal to the total loss coefficient.

Four operating points were selected to test the validity of the program. Three were off-design points at which measured data were available and the fourth was the design point itself. Table II contains details of the selected test points for Run 1.

The program variables were then changed and the following new solution flow path was selected:

1. Stator and rotor loss coefficients were those calculated by Traupel's method.
2. The blockage factor,  $\xi^*$ , was equal to the profile loss coefficient.

After reviewing the results of Runs 1 and 2, a further modification was made to the program. The original program contained a subroutine which checked between-streamline continuity. If the total mass flow rate at the stator and rotor exits was not evenly divided between the five streamlines,



the radial positions of the streamlines were adjusted and all steps were recalculated using the new streamline positions. Hence, for Run 3, a subroutine was removed and the main program was modified so that between-streamline continuity was not examined.

## B. COMPARISON WITH MEASURED DATA

The results of Run 1, 2, and 3 are tabulated in Table III. Run 1 showed predictions of mass flow rate which departed about 6% from the measured data. However, the horsepower predictions were off by as much as 16.17%. Furthermore, the computer program was unable to reach a solution for the design point.

Run 2 produced worse results as is evident from the table. Again, the program was unable to converge to a solution at the design point.

Run 3 produced more acceptable data. Additionally, convergence to a solution was noticeably faster and a solution was obtained at the design point. Because of this, the method used in Run 3 was used to map the drive turbine performance. The computer program used to obtain the results of Run 3 is described in detail in Appendix A and is listed in Appendix G. The results of Run 3 are shown plotted in Figures 3 through 8.

To obtain the plots in Figures 3 and 6, a value of the total inlet temperature was approximated by the method of Vavra as contained in Ref. [14]. It was assumed that the static turbine discharge temperature should not be less than





45°F (505°R). This corresponds to the approximate temperature at which condensation of moisture in the air, assuming 100% relative humidity, will occur. The inlet temperature was given by

$$\text{Total Inlet Temperature} = \frac{\text{Static Outlet Temperature}}{1 - \eta_s \left[ 1 - \left( \frac{1}{\delta_T} \right)^{\frac{\gamma-1}{\gamma}} \right]}$$

where  $\eta_s$ , the total-static turbine efficiency was assumed to be 81%, and  $\delta_T$ , was the total to static pressure ratio. The total inlet temperature corresponding to each pressure ratio is given in Table IV.

The computer output corresponding to each point on Figures 3 through 8 is contained in Appendix F. Only one side of the dual flow turbine was analyzed, thus, the resulting printed values of horsepower, referred horsepower, moment, referred moment, flow rate and referred flow rate must be doubled to obtain the actual turbine characteristics which have been plotted in Figures 3 through 8.



#### IV. DISCUSSION

The agreement of both the predicted flow rate and the horsepower obtained in Run 3 with turbine test data was encouraging. It is to be noted however, that this agreement was obtained using a procedure which was conceptually incorrect. In Runs 1 and 2, between-streamline continuity was checked and the streamlines were adjusted as necessary. In Run 3, between-streamline continuity was not checked, and as a result, the mass flow rate between streamlines was not precisely 25% of the total flow rate. It is noted however, that the deviations were less than 10.0% and while the radial positions of the streamlines varied by 10.%, the differences between predicted and measured output horsepower decreased from 24% to 4.5%. Since the enthalpy change on each streamline was computed using Euler's turbine equation, the total horsepower obtained by integration is sensitive to the streamline radial positions. On the other hand, the calculation of the overall mass flow rate is primarily a function of the blade throat openings and inlet conditions of the flow. Consequently, in relaxing the requirement for between-streamline continuity, the output horsepower was changed significantly, while the overall flow rate was not.



Using this procedure, which preserves overall continuity, a performance map for the turbine was produced (Fig. 3-8) which agreed well with the off-design performance measurements made at lower speeds (Table III). It is noted however, that the inability of the program in its original form to predict the measured turbine performance is not explained, and both the program itself and the data input for the geometry should be closely re-examined.

The difficulty in obtaining convergence to a solution at some operating points above the pressure ratio of 2.0 is likely to be the result of choking occurring on one or more of the streamlines. This was suspected but not fully explored.

Finally, although the program was eventually made to run on the mini-computer, the time required to put the program into its final form was excessive since the original program was not written with segmentation in mind. When the segmented program was completed, only one operating point per run could be obtained. Thus, excessive time was spent compiling and loading the program. The execution time for the program averaged 2 minutes at the lower pressure ratios and up to 30 minutes at the higher ones. This would be unacceptable if many points were to be examined.



## V. CONCLUSIONS

The program for calculating the performance of a single stage axial turbine reported by Macchi was revised, corrected and segmented and made to run on the Laboratory mini-computer. When applied to the geometry of the air-drive turbine of the compressor test rig, selecting specific options for the representation of loss coefficients, the revised program failed to converge when design-point test conditions were input. Also, the computed horsepower was in error by as much as 24% when the program predictions were compared with specific test data obtained from the rig at off-design (lower speed) conditions. The revised program did however closely reproduce the results given by Macchi in his original report for a specific turbine geometry.

When the requirement that the computed stream surfaces be such that they divided the flow exactly into equal 25% increments was removed, the program converged satisfactorily for design point conditions and gave agreement with test data to within 5% in flow rate and horsepower at off-design conditions.

The complete performance map for the air drive turbine was obtained with the program following this revision. Based on the favorable comparison with data so far obtained, the map is likely to describe the performance to better than a 10% uncertainty. This is considered to be satisfactory for





sizing the turbocharger for the proposed compressor rig modification.

The following recommendations are made concerning further application or development of the computer program:

1. The failure of the program to converge before the final revision was made should be analysed closely, and the final revision removed if possible.
2. The geometrical input for the air drive turbine (which was taken from drawings) should be reexamined and the physical dimensions of the blade rows themselves should be measured.
3. Consideration should be given to putting the corrected original version of the program onto the IBM 370 computer so that, when successfully operating, a turbine map can be calculated with a single load.



TABLE I

TURBINE GEOMETRY

(see Figure 2; Dimensions in inches)

STATOR:

Hub Radius	2.764
Mean Radius	3.196
Tip Radius	3.627
Blade Chord	1.003
Blade Suction Side Radius of Curvature	2.8065
Maximum Blade Thickness	.2252
T.E. Projected Thickness	.03
T.E. Normal Thickness	.0186

ROTOR:

Hub Radius	2.693
Mean Radius	3.265
Tip Radius	3.837
Blade Chord	1.003
Blade Suction Side Radius of Curvature	2.8065
Maximum Blade Thickness	.2252
T.E. Projected Thickness	.03
T.E. Normal Thickness	.0186
Tip Clearance	.01(estimated)



TABLE II

MEASURED/DESIGN DATA USED TO VERIFY THE PROGRAM

POINT	RPM	T <sub>IN</sub>	(R) T <sub>OUT</sub>	(R) P <sub>TO</sub>	(PSI) P.R.	M( $\frac{\text{LBM}}{\text{SEC}}$ )	H.P.
1	18310	579.2	550.8	23.56	1.602	5.542	110.1
2	15200	557.4	517.8	20.43	1.390	4.698	63.27
3	21300	578.9	506.8	27.13	1.846	7.033	172.0
4*	30500	640.0	---	41.16	2.8	10.85	485

\*Design Point



TABLE III

COMPARISON OF PREDICTED TURBINE PERFORMANCE  
VS MEASURED PERFORMANCE

POINT	RUN I			HORSEPOWER		
	<u>FLOWRATE</u> PREDICT.	MEAS.	%DIFF.	PREDICT.	MEAS	%DIFF.
1	5.88	5.542	6.09	99.5	110.1	9.63
2	4.74	4.698	0.89	52.5	63.27	16.17
3	7.04	7.033	0.009	163.64	172.0	4.86
4	N.C.	10.85	---	N.C.	485	---
RUN 2						
1	6.06	5.542	9.35	90.92	110.1	17.4
2	4.90	4.698	4.29	49.76	63.27	21.35
3	7.30	7.033	3.80	130.76	172.0	23.97
4	N.C.	10.85	---	N.C.	485	---
RUN 3						
1	5.82	5.542	5.01	113.12	110.1	2.74
2	4.66	4.698	0.81	61.96	63.27	2.09
3	7.04	7.033	0.10	179.68	172.0	4.47
4	10.40	10.85	4.15	444.18	485	8.42

NC: Computer program would not converge to a solution after a large number of iterations.





TABLE IV

VALUES OF ASSUMED TOTAL INLET TEMPERATURE FOR EACH  
PRESSURE RATIO GIVEN IN FIGS. 3, 5, 6, AND 7

<u>PRESSURE RATIO</u>	<u>TOTAL INLET TEMPERATURE (°R)</u>
1.4	545.5
1.6	562.6
1.8	577.3
2.0	591.0
2.2	603.6
2.4	615.3
2.6	626.1
2.8	636.6



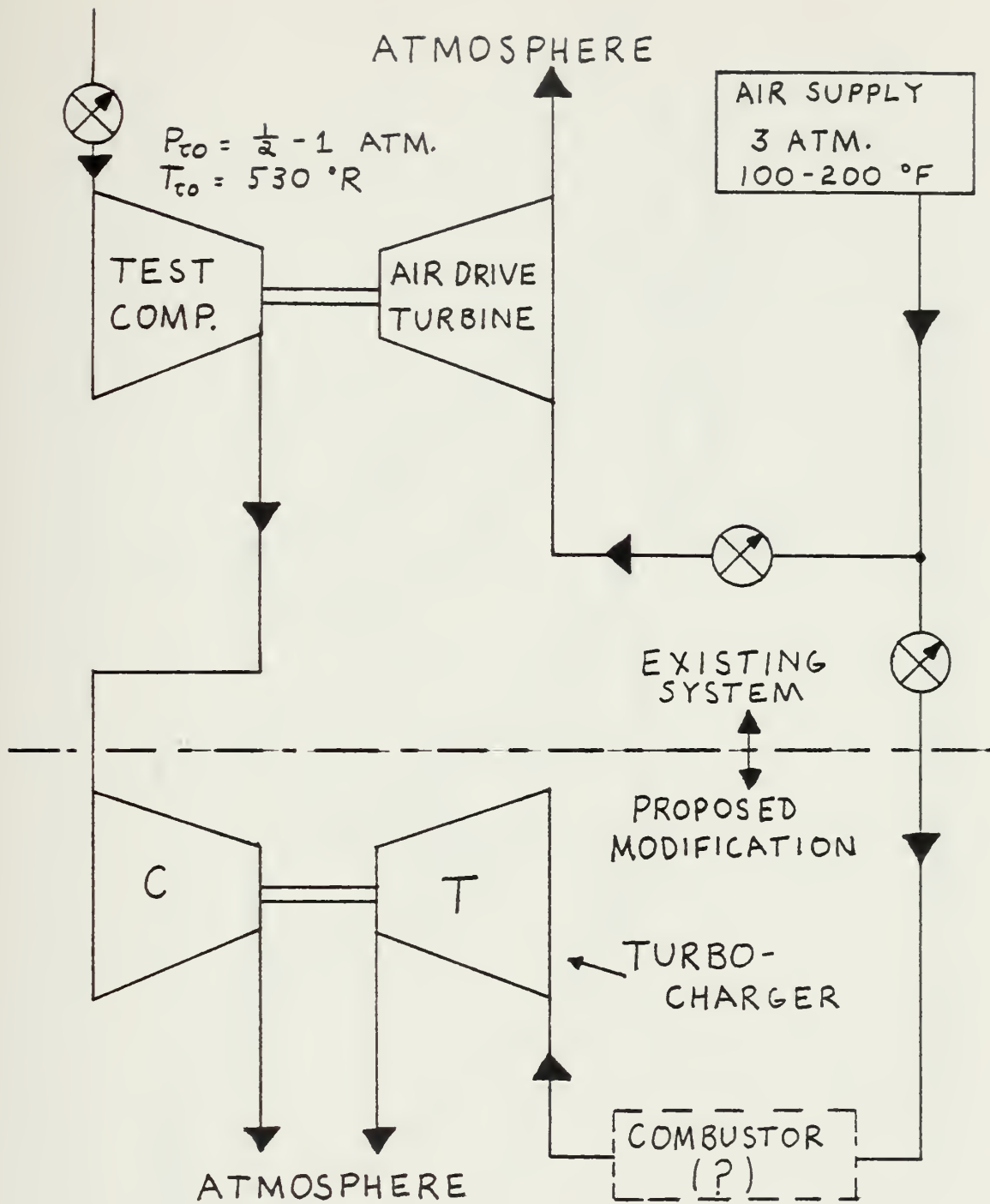

FIGURE 1: SCHEMATIC OF THE COMPRESSOR TEST RIG, WITH PROPOSED MODIFICATIONS



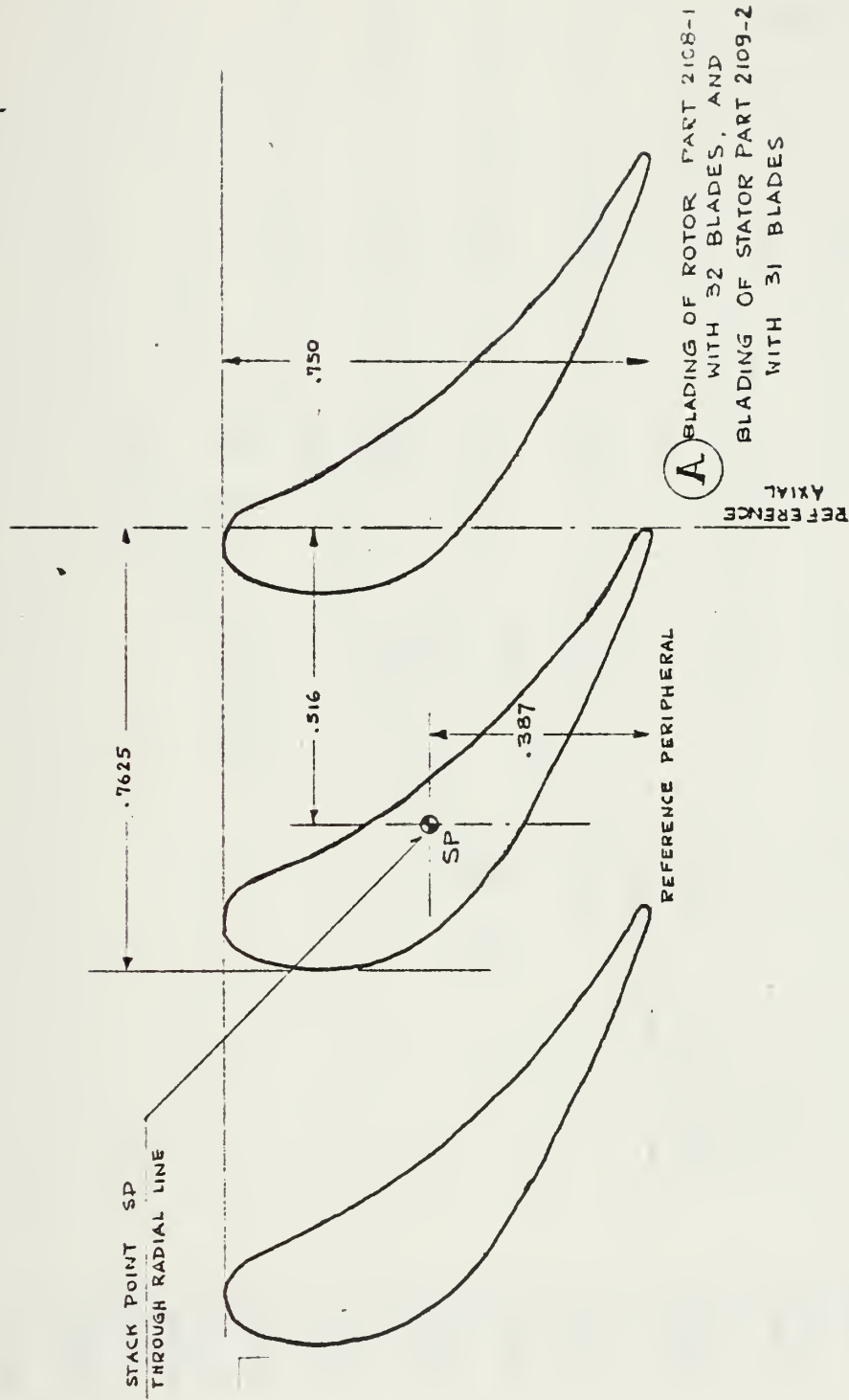

FIGURE 2: TURBINE ROTOR AND STATOR BLADE SHAPES



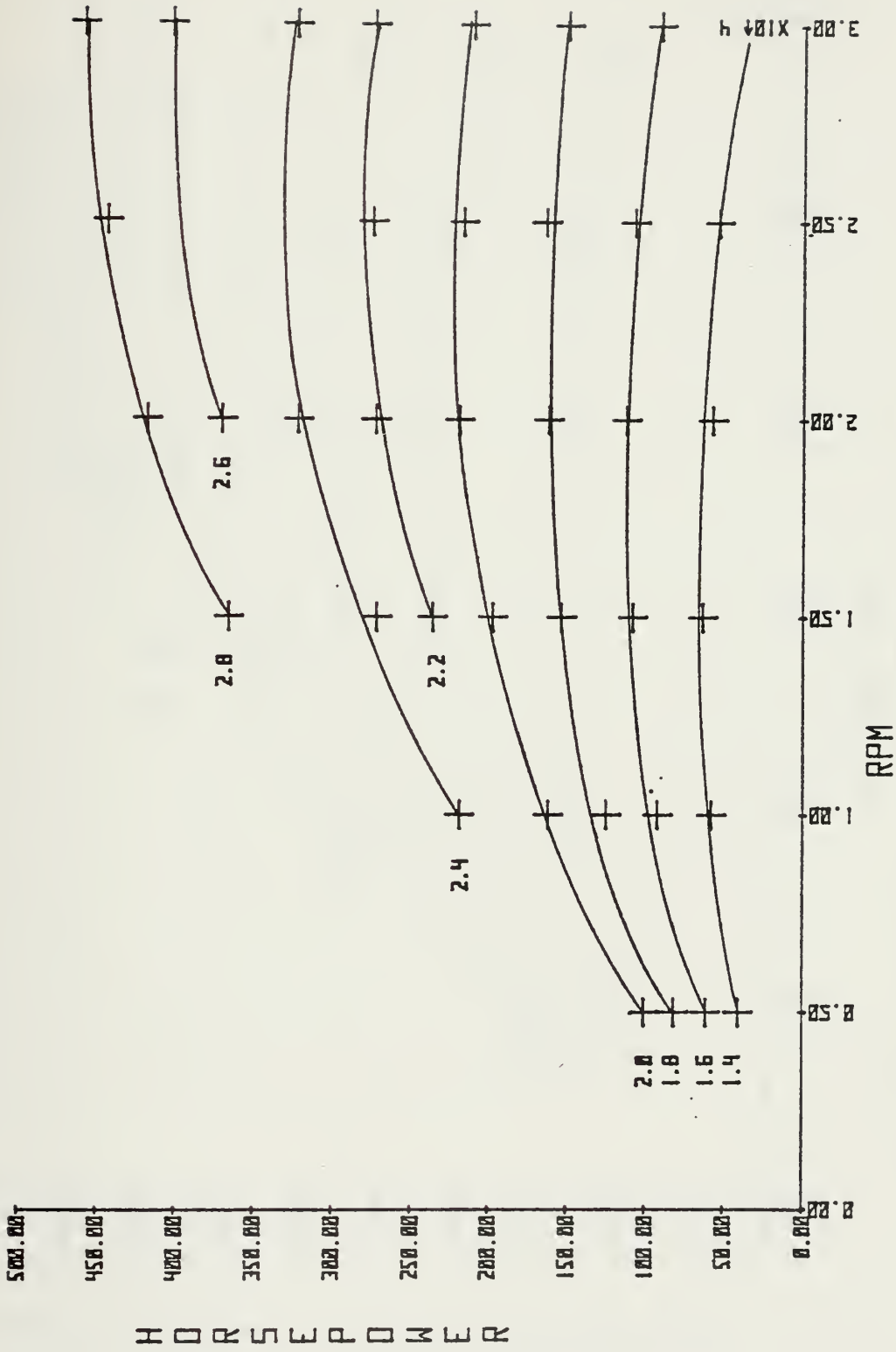

FIGURE 3: PREDICTED HORSEPOWER VS RPM AS A FUNCTION OF PRESSURE RATIO, AT TEMPERATURES TO AVOID CONDENSATION





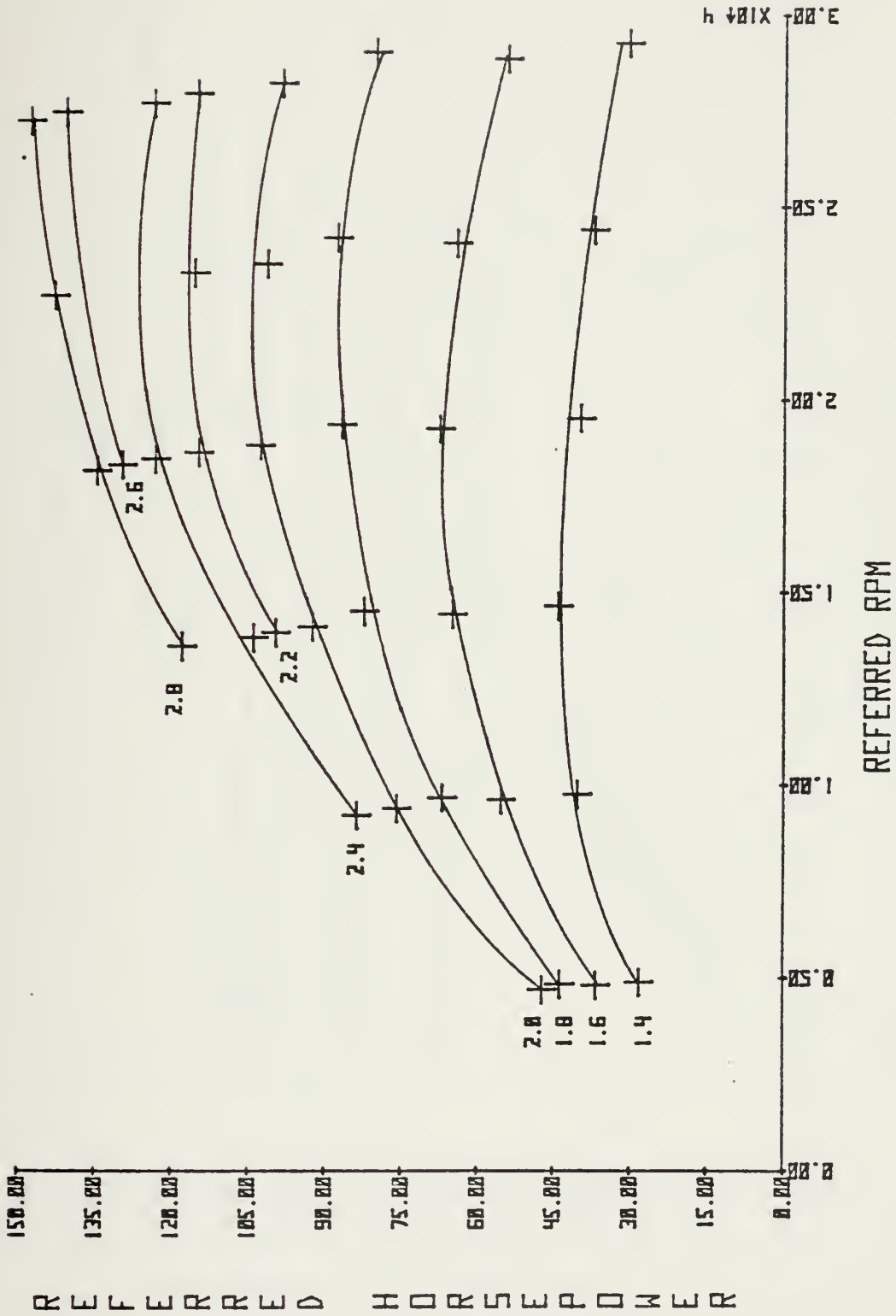

FIGURE 4: PREDICTED REFERRED HORSEPOWER VS REFERRED RPM AS A FUNCTION OF PRESSURE RATIO



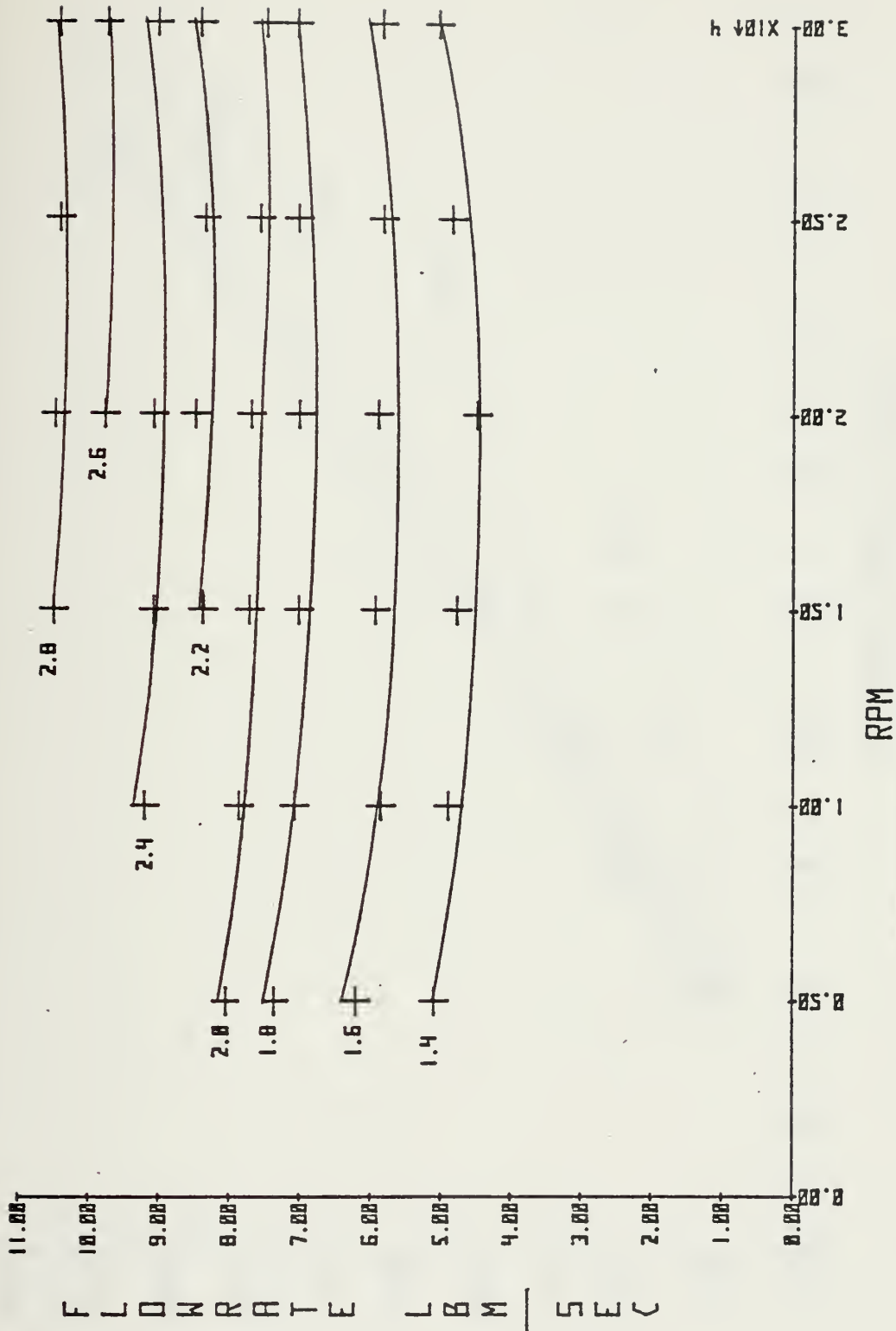

FIGURE 5: PREDICTED FLOWRATE VS RPM AS A FUNCTION OF PRESSURE RATIO AT TEMPERATURES TO AVOID CONDENSATION.



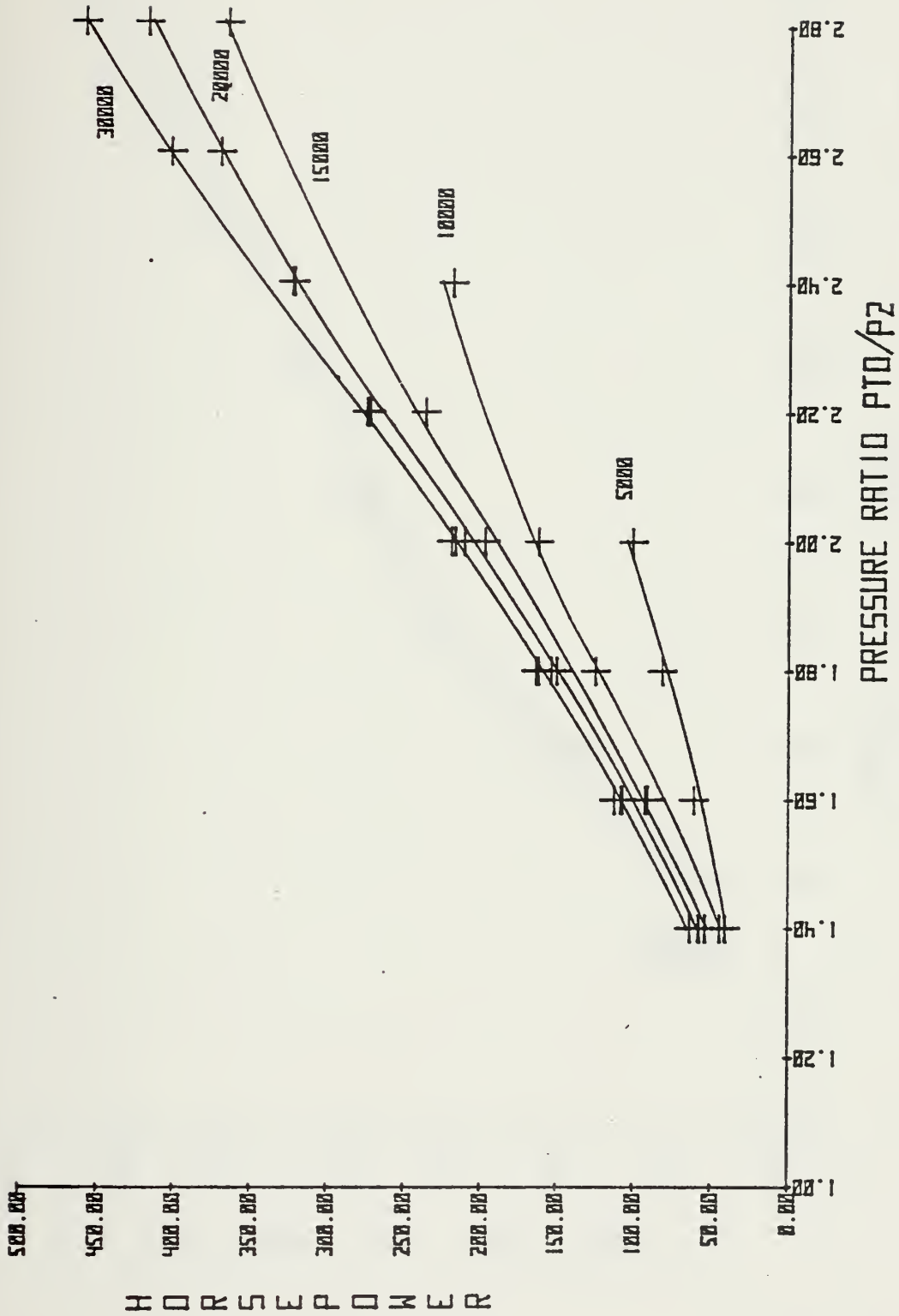

FIGURE 6: PREDICTED HORSEPOWER VS PRESSURE RATIO AS A FUNCTION OF RPM, AT TEMPERATURES TO AVOID CONDENSATION



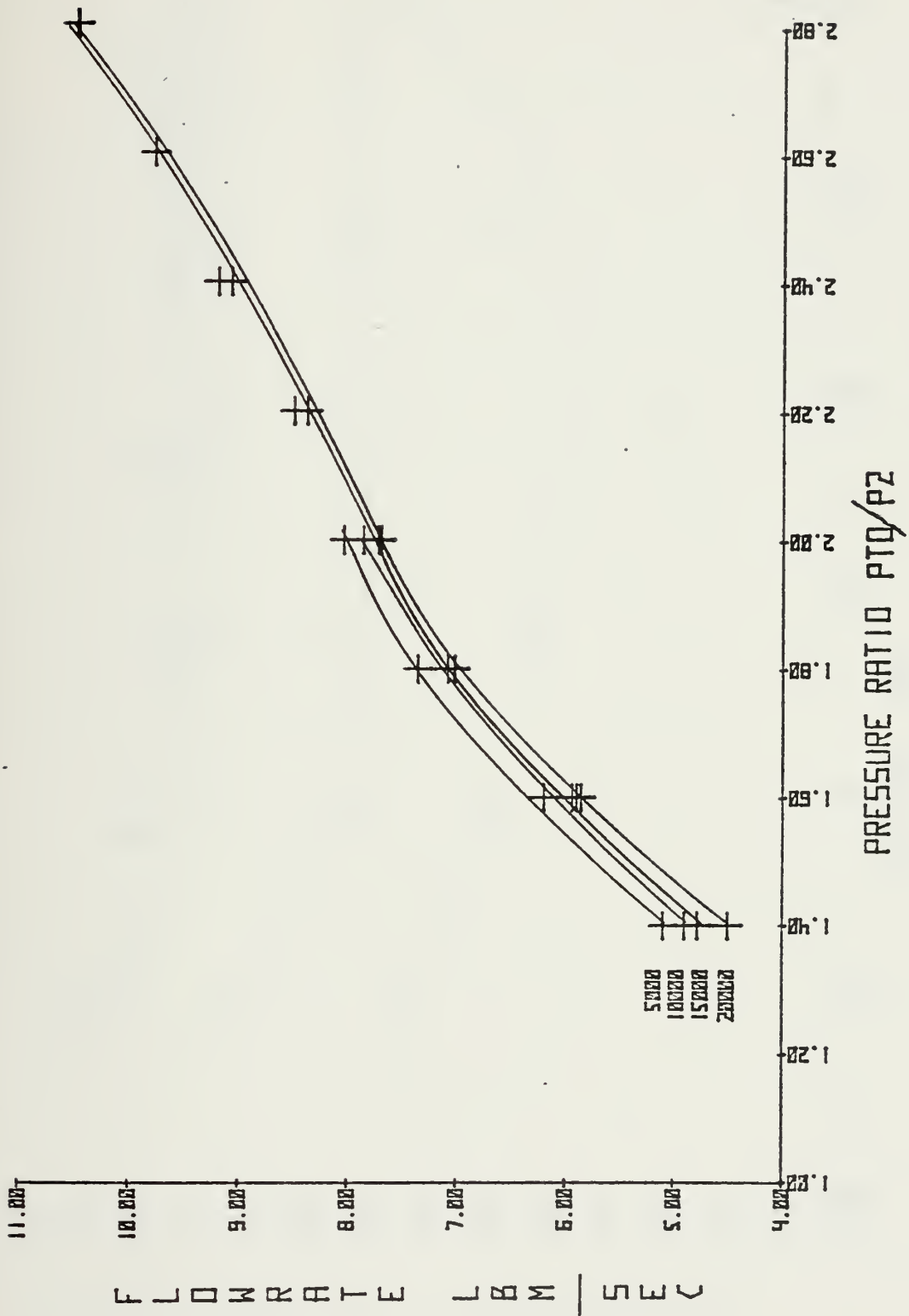

FIGURE 7: PREDICTED FLOW RATE VS PRESSURE RATIO AS A FUNCTION OF RPM AT TEMPERATURES TO AVOID CONDENSATION.





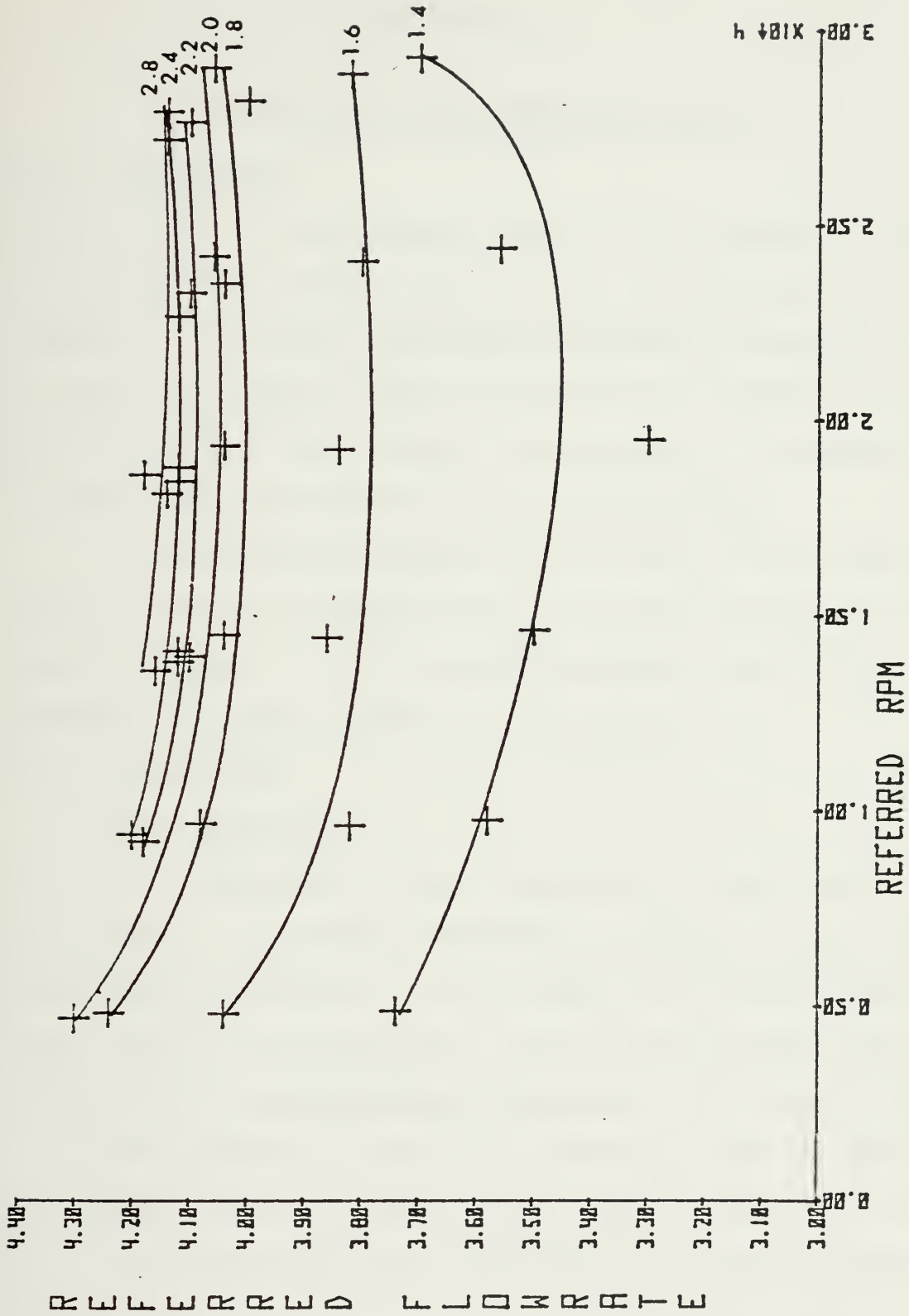

FIGURE 8: PREDICTED REFERRED FLOWRATE VS REFERRED RPM AS A FUNCTION OF PRESSURE RATIO



## APPENDIX: A

### DESCRIPTION OF THE COMPUTER PROGRAM

#### A-1. INTRODUCTION

To enable the program to run on the laboratory computer, the program was divided into 4 parts; a main program and 3 segments. A detailed discussion of program segmentation on the HP-1000 computer series is contained in Appendix C. In the description which follows, the program is treated as if it were one large program with many subroutines.

The description follows the individual steps from start to finish in the analysis. A program flowchart is given in Figure A-1 and the FORTRAN symbols used in the program are listed in Tables A-I to A-IX.

#### A-2. DESCRIPTION

##### A-2.1 Input Data

There are 4 basic categories of input data; turbine geometry, operating conditions, special data and program control parameters. Since there was no card reader input device on the computer, all data were entered using either data or specification statements. Explanations of the turbine geometry, operating conditions, special data and program control parameters are found in Table A-I through A-V. The nomenclature for the blading is given in Figure A-2.



### A-2.2 Initial Geometric Calculations

The first calculation performed is to establish the 5 streamline locations at the stator inlet (station 0). The streamlines are initially positioned such that there are equal areas (25% of the total flow area) between them. Next, blade heights of the stator and rotor are calculated using the hub and tip radii of each blade. Blade spacings for the stator and rotor are computed at 3 streamlines; hub, mean and tip. The blade spacing on the mean streamline for the stator is given by

$$S = \frac{2\pi}{Z_s} R_m \quad (A-1)$$

where

S = Blade spacing

$Z_s$  = Number of stator blades

$R_m$  = Mean stator radius

### A-2.3 Calculation of Gas Outlet Angles

Subroutine VAVRA calculates gas outlet angles for both stator and rotor. The method is that of M.H. Vavra [Ref. 1]. The equation programmed in the subroutine is

$$\alpha = \cos^{-1} \left[ \frac{a}{S} + 4 \frac{t_e}{S} \left( 1 - \frac{\cos^{-1} \left( \frac{a}{S} \right)}{90} \right) \right] \quad (A-2)$$

where

$\alpha$  = Gas outlet angle

a = Throat opening

S = Blade spacing

$t_e$  = Projected trailing edge thickness

This method is much simpler than that used by Macchi since



there is no variation in outlet angle with Mach number (for sub-sonic conditions). Therefore, once calculated, the stator and rotor exit angles remain unchanged. Subroutine VAVRA computes exit angles for the hub, mean and tip streamlines. The outlet angles at streamlines two and four are computed later in the subroutines STATR and ROTO2.

Before printing the input data, the program calculates the mean throat opening for the stator and for the rotor. The ten equally spaced radii and corresponding throat openings (part of the input geometry) are fitted with a fourth order Chebyshev polynomial. A throat opening corresponding to the mean radius is thus obtained. In the present application of the program to the drive turbine, the mean throat opening was obtained from the design drawing of the blading shown in Figure 2. It was assumed that the throat opening varied linearly with radial position and hence the throat openings at other radii could be calculated. The resulting throat openings are shown in the computer output under the heading of "Input Prints". The design values of the stator and rotor throat areas were obtained from the original design notes of M.H. Vavra.

#### A-2.4 Calculation of the Flow Rate

Subroutine CHAN is called to calculate the mass flow rate entering the stator. The equations used are as follows:





$$T = \frac{T_{T0}}{1 + \frac{\gamma-1}{2} M_0^2} \quad (\text{A-3})$$

$$V = \sqrt{g_c \gamma R T} \quad (\text{A-4})$$

$$P = \frac{P_{T0}}{1 + \frac{\gamma-1}{2} M_0^2} \quad (\text{A-5})$$

$$\rho = P / RT \quad (\text{A-6})$$

$$A = \pi [R_{TIP}^2 - R_{HUB}^2] \quad (\text{A-7})$$

$$\dot{m} = \rho A V \quad (\text{A-8})$$

$$\dot{m}_{REF} = \frac{\dot{m}}{P_{T0}} \sqrt{\frac{RT_{T0}}{g_c}} \quad (\text{A-9})$$

$\dot{m}_{ref}$  is the reference (dimensionless) flowrate

and is used to check overall continuity later in the program.

#### A-2.5 Solution of the Equation of Motion for the Stator

Subroutine STATR is called to solve the equation of motion for the stator outlet conditions. The equation of motion which is programmed is as follows:

$$\frac{d(\ln Y_1^2)}{dX_1} = -\cos^2 \alpha_1 \left[ -\left( K 2 r_m \frac{\delta R}{L^2} \right) - \left( \frac{4L^2 + (\delta r)^2}{4L^2} \right) \right. \\ \left. \frac{dS_1^*}{dX_1} \right] - 2 \tan \alpha \frac{d\alpha_1}{dX_1} - \frac{2}{X_1} \sin^2 \alpha_1 + \\ \frac{C_1 \cos^2 \alpha_1}{Y_1^2 V_{a_{1m}}^2} \frac{dH}{dX_1} - \left[ \frac{C_1 H \cos^2 \alpha_1}{Y_1 V_{a_{1m}}^2} - \sin^2 \alpha_1 \right] \frac{dS_1^*}{dX_1} \quad (\text{A-10})$$



where  $C_1 = 2g_c J$  (a constant to convert H, the enthalpy from  $\frac{\text{BTU}}{\text{LBM}}$  TO  $\frac{\text{FT}^2}{\text{sec}^2}$ )

$$Y_1 = \frac{V_a(I)}{V_a(3)} = \frac{\text{Axial velocity at a streamline}}{\text{Axial velocity at mean streamline}}$$

$$X_1 = \frac{R(I)}{R_m} = \frac{\text{Streamline radius}}{\text{Mean streamline radius}}$$

$$\frac{ds^*}{dX_1} = \frac{d}{dX} \left[ \ln \left[ \frac{1 - \frac{Y_1^2 V_{a,m}^2}{C_1 H \cos^2 \alpha_1}}{1 - \frac{Y_1^2 V_{a,m}^2}{C_1 H \cos^2 \alpha (1-\xi)}} \right] \right]$$

$\xi$  = Stator loss coefficient  
(which is initially assigned an estimated value)

The derivation of this form of the equation of motion is given in Appendix B. However, at this stage of the analysis, the streamline curvature is assumed to be zero. Therefore, the equation of motion becomes:

$$\frac{d(\ln Y_1^2)}{dX_1} = -2 \tan \alpha_1 \frac{d\alpha_1}{dX_1} - \frac{2}{X_1} \sin^2 \alpha_1 + \frac{C_1 \cos^2 \alpha_1}{Y_1^2 V_{a,m}^2} \cdot \frac{dH}{dX_1} + \left[ 1 - \frac{C_1 H \cos^2 \alpha_1}{Y_1^2 V_{a,m}^2} \right] \frac{ds^*}{dX_1} \quad (\text{A-11})$$

The equation of motion is solved when the value of  $Y_1$  at each streamline satisfies the equation. The solution is to first put the equation in the form:

$$\frac{d(\ln Y_1^2)}{dX_1} = I(X) \quad (\text{A-12})$$

where  $I(X)$  consists of the right hand side of equation (A-11). Integrating equation (A-12) yields;



$$\ln Y_1^2 = \int_{x_0}^x I(x) dx_1 + \ln c^2 \quad (\text{A-13})$$

where  $\ln c^2$  is the constant of integration when  $x = 1$  and  $Y_1 = 1$ .

1. With these boundary conditions Eq. (A-13) gives

$$\ln c^2 = - \int_{x_0}^1 I(x) dx_1 \quad (\text{A-14})$$

using Eq. (A-14) in Eq. (A-13),

$$\ln Y_1^2 = \int_{x_0}^{x_1} I(x) dx_1 - \int_{x_0}^1 I(x) dx_1 \quad (\text{A-15})$$

which becomes

$$\ln Y_1^2 = \int_1^{x_1} I(x) dx_1 \quad (\text{A-16})$$

Taking the inverse natural log and the square root of both sides

$$Y_1 = e^{\frac{1}{2} \int_1^x I(x) dx_1} \quad (\text{A-17})$$

Equation (A-17) is the form of the equation of motion solved in subroutine STATR. Solution of the equation gives five values of  $Y_1$  and thus the value of the axial velocity at each of the five streamlines. Initially, the value of  $Y_1$  is taken to be 1 and the value of  $\frac{ds^*}{dx_1}$  is taken to be zero. In succeeding iterations, the calculated value of  $Y_1$  is used to obtain a new value of  $\frac{ds^*}{dx_1}$ , and so on.

After calculating five values of  $Y_1$ , the stator exit conditions are calculated at each streamline from the geometry of the velocity diagram. The convention for positive



and negative angles and velocities is defined in Figure A-3.

The required relations are the following:

$$V_{a_1} = V_{a_1} (3) \cdot Y_1 \quad (\text{A-18})$$

$$V_{u_1} = V_{a_1} \cdot \text{TAN } \alpha_1 \quad (\text{A-19})$$

$$V_1 = V_{a_1} / \text{COS } \alpha_1 \quad (\text{A-20})$$

$$V_{R_1} = -V_{a_1} \left[ \Delta R / 2L \right] \quad (\text{A-21})$$

where L is the axial distance between stations and  $\Delta R$  is the change in radial position of the streamline.  $V_{R_1}$ , the radial component of velocity, is taken to be zero at this stage in the calculation.

$$V_1 = \sqrt{V_1^2 + V_R^2} \quad (\text{A-22})$$

$$T_1 = T_{T0} - \frac{V_1^2}{2g_c J C_p} \quad (\text{A-23})$$

$$T_{1,5} = T_{T0} - \left[ \frac{T_{T0} - T_1}{1 - \xi_s} \right] \quad (\text{A-24})$$

$$\text{P.R.} = P_1 / P_{T0} \quad (\text{A-25})$$

$$P_1 = P_{T0} \left[ \frac{T_{1,5}}{T_{T0}} \right]^{\frac{\gamma}{\gamma-1}} \quad (\text{A-26})$$

$$M_1 = V_1 / \sqrt{\gamma g_c R T} \quad (\text{A-27})$$

After the above quantities have been calculated at each streamline, subroutine STATR returns to the main program.





## A-2.6 Calculation of the Stator Loss Coefficients

The calculation of the stator loss coefficients at each streamline is accomplished by subroutine ALOS1.

The method of solution to obtain these loss coefficients is that formulated by Traupel [Ref. 7]. In Traupel's method, the value of the total loss coefficient is given by

$$\xi_{\text{total}} = \xi_{\text{profile}} + \xi_{\text{wall}} + \xi_{\text{remaining}} \quad (\text{A-28})$$

The calculation of  $\xi_{\text{total}}$  requires 9 subroutines. Figure A-4 describes the connection between the subroutines and subroutine ALOS1.

The first step is to obtain the value of the total profile loss coefficient,  $\xi_p$ .  $\xi_p$  is defined by Traupel to be

$$\xi_p = \xi_{p0} \chi_m \chi_s + \xi_m + \xi_f \quad (\text{A-29})$$

where  $\xi_{p0}$  = initial value of the profile loss coefficient

$\chi_m$  = mach number correction factor

$\chi_s$  = trailing edge thickness correction factor

$\xi_m$  = loss coefficient due to mixing losses and separation losses

$\xi_f$  = loss coefficient due to fan losses

The total profile loss coefficient is calculated in the following manner. First, data for initial profile loss ( $\xi_{p0}$ ) as a function of gas outlet angle ( $\alpha_1$ ) for various values of gas inlet angle ( $\alpha_0$ ) is read from an array (Fig. A-5).



This is done by subroutine TRAU1 and functions XPO and YC. The values of  $\xi_{po}$  are contained in two arrays XPO1 (5, 8) and XPO2 (6, 8). This is because the data shown plotted in Fig. A-5 has been divided into two sets. One set is for values of  $\alpha_1$  between  $40^\circ$  and  $80^\circ$ . The other is for values of  $\alpha_1$  between  $80^\circ$  and  $170^\circ$ . The FORTRAN symbols for the two ranges of values of  $\alpha_1$  are ALFO1(I) and ALFO2(I) respectively. The FORTRAN symbol for the gas inlet angle is ALF1 (J) once the data points selected from the plot are entered, fifth and sixth degree polynomials respectively are fitted through the data points. The value of  $\xi_{po}$  can then be determined for given values of  $\alpha_1$  and  $\alpha_0$ .

The mach number correction,  $X_m$  is obtained from Fig. A-5. Subroutine CSIM calculates the value of  $X_m$  using straight line approximations of the plot.

Subroutine CID calculates the remaining terms in the expression for  $\xi_p$ . These are  $X_s$ ,  $\xi_m$ ,  $\xi_f$ . They are obtained from the data in Fig. A-6 using the linear interpolation. The abscissa of the curves for  $X_s$  and  $\xi_m$  is either f or 1-f where f is defined as

$$f = 1 - \frac{\delta}{t \sin \alpha_1} \quad (A-30)$$

where  $\delta$  = normal trailing edge thickness.

t = blade spacing.

$\alpha_1$  = gas outlet angle.

The loss coefficient due to wall friction,  $\xi_w$ , is calculated using



$$\xi_w \approx \int_{p_0} \chi_p \frac{t \sin \alpha}{l} \quad (\text{A-31})$$

where  $t$  - blade maximum thickness

$l$  = blade height

This equation is programmed in subroutine CSIW.

The value of  $\xi_R$  is obtained using subroutine CSIR.

$\xi_R$  is defined by Traupel to be an all-inclusive loss coefficient which accounts for any remaining losses not previously defined. It is written as

$$\xi_R = \chi_L \xi_{R0} \quad (\text{A-32})$$

$\xi_{R0}$  is an initial value of  $\xi_R$  which depends on the value of  $\phi$ , where  $\phi$  is given by

$$\phi = \frac{v_1 \sin \alpha_1}{U} \quad (\text{A-33})$$

in which  $v_1$  = true velocity of gas

$v$  = blade speed

A plot of  $\xi_{R0}$  vs  $\phi$  is shown in Fig. A-7. The correction  $\chi_L$  is a function of  $s/l$  where

$s$  = chord length

$l$  = blade height

and is obtained using the data in the lower half of Fig. A-7.

The total stator loss coefficient is computed for 3 streamlines; those at the hub, mean and tip.

The loss coefficients at streamlines 2 and 4 are obtained by linear interpolation.



A refinement to the stator loss coefficient may be applied depending on the input value of one program control parameter. The following 3 variations of  $\xi_s$  are available:

$$\xi_s = \frac{\left[ \frac{1 + \xi_0}{1 + \xi_0 \frac{P}{P_{TO}}} \right]^{\frac{\gamma-1}{\gamma}} - 1}{\left[ \frac{1}{\frac{P}{P_{TO}}} \right]^{\frac{\gamma-1}{\gamma}} - 1} \quad (\text{A-34})$$

$$\xi_s = \xi_0 \quad (\text{A-35})$$

and

$$\xi_s = \frac{\left[ \frac{1 + \xi_0}{1 + \xi_0 \beta^*} \right]^{\frac{\gamma-1}{\gamma}} - 1}{\left[ \frac{1}{\beta^*} \right]^{\frac{\gamma-1}{\gamma}} - 1} \quad (\text{A-36})$$

where  $\xi_0$  = loss coefficient calculated using the method of Traupel

$$\beta^* = \left[ 1 + \frac{\gamma-1}{2} (.8)^2 \right]^{\frac{\gamma-1}{\gamma}} \quad (\text{A-37})$$

The values of the program control parameter required to select between options are given in Table A-V.





Before returning to the main program, subroutine ALOS1 calculates a value of  $\xi^*$  which is a blockage factor to be used in the equation of continuity. There are three ways to define  $\xi^*$ ; they are as follows:

$$\int \rho^* = \int \rho_0 \quad (\text{A-38})$$

$$\int \rho^* = \frac{1}{2} \int \rho_0 \quad (\text{A-39})$$

$$\int \rho^* = \int \rho_P \quad (\text{A-40})$$

#### A-2.7 Solution of the Continuity Equation After Returning to the Main Program

The overall continuity at the stator exit is checked. Subroutine FLOWR performs this task. The flow chart for FLOWR is given in Fig. A-8. In FLOWR the mass flow rate required by continuity is checked against the calculated mass flow rate. If the calculated flow rate does not agree with that required by continuity, adjustments are made to the axial velocity and/or the inlet Mach number, as will be explained.

The mass flow required by continuity is

$$\dot{m}_{REQD} = \frac{\dot{m}_{REF}}{Z_s \cdot A_m R_m} \quad (\text{A-41})$$

where  $\dot{m}_{REF}$  = reference mass flow rate as computed in subroutine CHAN



$Z_s$  = # of stator blades

$A_m$  = mean stator throat opening

$R_m$  = mean stator radius

The mass flow rate at each streamline computed in this subroutine is

$$\dot{m}_{ACT} = \left[ \frac{P_{TE}}{P_{TO}} \right] \sqrt{\frac{T_{TE}}{T_{TO}}} \left[ \frac{A(I)}{A(3)} \right] Z \Phi \quad (A-42)$$

where  $Z$  is an area reduction coefficient defined by

$$Z = \frac{H^{***} - 1}{H^{***} - 1 + \xi^*} \quad (A-43)$$

$Z$  gives the percentage of flow area between the blades over which it is permissible to assume a uniform velocity. The boundary layer on both sides of the flow limits the available flow area and the backage facotr,  $Z$ . accounts for this.

Equation A-43,  $Z$  is seen to be a function of the energy parameter  $H^{***}$  and  $\xi^*$ .  $\xi^*$  is the value of the loss coefficient returned from subroutine ALOS1. The energy parameter is defined as



$$H^{***} = \frac{\delta 3}{\delta 1} = \frac{\text{Energy thickness}}{\text{Displacement thickness}} \quad (\text{A-44})$$

$H^{***}$  can be written as

$$H^{***} = \frac{\left[ \frac{1}{X_E^{-1}} + \frac{1}{3m+1} + \frac{X_E}{5m+1} + \frac{X_E^2}{7m+1} + \frac{X_E^3}{9m+1} + \frac{X_E^4}{11m+1} \right]}{\left[ \frac{1}{X_E^{-1}} + \frac{1}{m+1} + \frac{X_E}{3m+1} + \frac{X_E^2}{5m+1} + \frac{X_E^3}{7m+1} + \frac{X_E^4}{9m+1} \right]} \quad (\text{A-45})$$

where:

$$m = .15$$

$$X_E = 1 - \left( \frac{P}{P_{TO}} \right)^{\frac{\gamma-1}{\gamma}} \quad \text{for unchoked flow}$$

$$X_E = 1 - [P_{CRIT}]^{\frac{\gamma-1}{\gamma}} \quad \text{for choked flow}$$

and

$$P_{CRIT} = \left[ \frac{2}{\gamma+1} \right]^{\frac{\gamma}{\gamma-1}}$$

The derivation of  $Z$  and  $H^{***}$  as given in Appendix B.

The expression for  $\Phi$ , the flow function, for unchoked flow is

$$\Phi = \sqrt{\left( \frac{2\gamma}{\gamma-1} \right) \left( \frac{P}{P_{TO}} \right)^{\frac{2}{\gamma}} - \left( \frac{P}{P_{TO}} \right)^{\frac{\gamma+1}{\gamma}}} \quad (\text{A-46})$$

and for choked flow is

$$\Phi = \left[ \frac{2}{\gamma+1} \right]^{\frac{1}{\gamma-1}} \sqrt{\frac{2\gamma}{\gamma+1}} \quad (\text{A-47})$$



After calculating for each streamline, the flow rate is integrated from hub to tip and the resulting value is compared with  $\dot{m}_{reqd}$ . If the two values of flow rate agree to within a specified tolerance (see Table A-IV) continuity is considered to be satisfied. Then, after calculating the total percentage of mass flow between adjacent streamlines, subroutine FLOWR returns to the main program.

If the flow rates are not within tolerance the program checks to see if the actual mass flow is too high. If it is too high, the value of the axial velocity is lowered proportionally to the difference between the actual and required flow rates.

If the actual flow rate is too low, the procedure is more complicated. First, the flow is checked to determine whether choking has occurred. Streamlines one and five are checked. If the flow is in fact choked at those streamlines, the inlet Mach number is lowered and the program loops back to recompute the reference mass flow rate and repeat the complete procedure.

If the flow is not choked, the axial velocity is raised proportionally to the difference between actual and required flow rates and subroutine FLOWR returns to the main program.

#### A-2.8 Calculation of the Rotor Inlet Conditions

Continuity having been satisfied through the stator, the rotor relative inlet conditions are calculated. In subroutine ROT01, the following expressions are used:





$$U = \frac{\omega R}{12} \quad (\text{A-48})$$

$$U_2 = \frac{\omega}{12} \cdot \frac{R_{\text{STATOR}}}{R_{\text{ROTOR}}} \quad (\text{A-49})$$

$$W_{u_1} = V_{u_1} - U \quad (\text{A-50})$$

$$\beta_1 = \text{TAN}^{-1} \left[ \frac{W_{u_1}}{V_{a_1}} \right] \quad (\text{A-51})$$

$$W_1 = \frac{V_{a_1}}{\cos \beta_1} \quad (\text{A-52})$$

$$W_1 = \sqrt{V_{R_1}^2 + W_1^2} \quad (\text{A-53})$$

$$T_{TE} = \frac{(T_1 + W_1)^2}{2g_c J_{cp} + \left( \frac{U_2^2 - U_1^2}{2g_c J_{cp}} \right)} \quad (\text{A-54})$$

$$P_{TE} = P_1 \left[ \frac{T_{TE}}{T_1} \right]^{\frac{\gamma}{\gamma-1}} \quad (\text{A-55})$$



$$H_E = (T_{TE})(.24)$$

(A-56)

Where  $T_{TE}$ ,  $P_{TE}$  and  $H_E$  are equivalent temperature, pressure and enthalpy respectively.

### A-2.9 Calculation of the Rotor Exit Conditions

Calculation of the rotor exit properties follows the same procedure as was used to compute the stator exit properties. The process is outlined here with notable differences explained. Subroutine ROT02 calculates the rotor exit properties. A flowchart of ROT02 is given in Fig. A-9.

The first step in ROT02 is to solve the equation of motion for each streamline. The equation of motion in terms of relative quantities is

$$\begin{aligned} \frac{d(\ln Y_2^2)}{dX_2} &= -\cos^2 \beta_2 \left[ 2K r_m \frac{\delta r}{L^2} - \frac{L^2 + \left(\frac{\Delta R}{2}\right)^2}{L^2} \right. \\ &\left. \frac{ds^*}{dX} \right] - 2 \tan \beta_2 \frac{d\beta_2}{dX_2} - \frac{2}{X_2} \sin^2 \beta_2 - \frac{4U_m \cos \beta_2 \sin \beta_2}{Y_2^2 Va_2^2} \\ &- \frac{2U_m U_2 \cos^2 \beta_2}{Y_2^2 Va_2^2} + \frac{C_1 \cos^2 \beta_2}{Y_2^2 Va_2^2} \cdot \frac{dH_E}{dX_2} + \\ &\left[ 1 - \frac{C_1 H_E \cos^2 \beta_2}{Y_2^2 Va_2^2} \right] \cdot \frac{ds_2^*}{dX_2} \end{aligned} \quad (A-57)$$



At this point in the calculation, streamline curvature is neglected. Hence, Eq. (A-57) reduces to

$$\begin{aligned} \frac{d(\ln Y_2^2)}{dX_2} = & -2 \tan \beta_2 \frac{d\beta_2}{dX_2} - \frac{2}{X_2} \sin^2 \beta_2 - \\ & \frac{4 U_m \cos \beta_2 \sin \beta_2}{Y_2 V_{a_2}} - \frac{2 U_m U_2 \cos^2 \beta_2}{Y_2^2 V_{a_2}^2} + \\ & \frac{C_1 \cos^2 \beta_2}{Y_2^2 V_{a_2}^2} \frac{dH_E}{dX_2} + \left[ 1 - \frac{C_1 H_E \cos^2 \beta_2}{Y_2^2 V_{a_2}^2} \right] \frac{dS_2}{dX_2} \end{aligned} \quad (A-58)$$

The derivation of Eq. (A-57) is contained in Appendix B. Equation (A-55) is similar in form to Eq. (A-10). Hence, the method of solution is identical to that employed by subroutine STATR. However, after solving the equation, the value of  $Y_2$  at each streamline is examined to determine whether or not it falls into the range  $.2 < Y_2 < 2.0$ . Values of  $Y_2$  greater than 2.0 are set equal to 2.0 while those less than .2 are set equal to .2. Successive values of  $Y_2$  at each streamline are compared, and when the values of successive iterations are within a specified tolerance (see Table A-IV), the iteration ends. The values of  $Y_2$  are used to calculate the rotor exit conditions using the following equations:

$$V_{a_2} = V_{a_2} (3) Y_2 \quad (A-59)$$



$$W_2 = \frac{V_{a2}}{\cos \beta_2} \quad (\text{A-60})$$

$$W_{R2} = \frac{(-V_{a2}) \cdot D \cdot CL}{2} \quad (\text{A-61})$$

$$T_2 = T_{TE} - \frac{W_2^2}{2g_c J C_p} \quad (\text{A-62})$$

$$V_{u2} = V_{a2} \tan \beta_2 \quad (\text{A-63})$$

$$W_{u2} = V_{u2} + U \quad (\text{A-64})$$

$$T_{2s} = T_{TE} - \frac{T_{TE} - T_2}{1 - \phi_R} \quad (\text{A-65})$$

$$P_2 = P_{TE} \left[ \frac{T_{2s}}{T_{TE}} \right]^{\frac{\gamma}{\gamma-1}} \quad (\text{A-66})$$

Subroutine ROTO2, then returns to the main program.

After calculating the rotor outlet conditions, the rotor loss coefficients are computed. Subroutine ALOS2





calculates the rotor loss coefficients following the process used in subroutine ALOS1 for the stator losses. The principle exception is that a tip clearance loss is also calculated and added to the total loss coefficient. The tip clearance loss coefficient is obtained from subroutine ALEAK which uses a straight line approximation to the curve shown in Fig. A-10. Subroutine ALOS2 also computes values of  $\xi^*$  and one of the three refinements to  $\xi_R$ .

Subroutine FLOWR is called to check continuity at the rotor exit. If continuity is satisfied, the program continues. If not, the same procedure is followed as previously explained for the stator outlet (Fig. A-1).

#### A-2.10 Accounting for Streamline Curvature

All calculations to this point have neglected streamline curvature and assumed that the streamlines remain fixed through the stator and rotor (Fig. A-11). The radial shift in a streamline between stator inlet and rotor outlet can be written as

$$\Delta R = R_{\text{STATOR INLET}} - R_{\text{ROTOR OUTLET}} \quad (\text{A-67})$$

This is the net radial shift in a streamline between stations '0' (stator inlet) and '2' (rotor outlet). It is shown in Section 16.4 of Ref. [5] that the radial shift in a streamline between the stator and the rotor (station 1) can be written as



$$\delta R = R_{\text{STATOR OUTLET}} - \frac{1}{2} \left[ R_{\text{STATOR INLET}} - R_{\text{ROTOR OUTLET}} \right] \quad (\text{A-68})$$

The angle between the meridional velocity  $V_m$  and the axial velocity  $V_1$  is  $\lambda$ . The radial velocity  $V_r$  can be expressed as

$$V_R = V_a \text{TAN } \lambda \quad (\text{A-69})$$

and from Fig. 16(1) of Ref.[5], it follows that

$$\text{TAN } \lambda = \frac{-\Delta R}{2L} \quad (\text{A-70})$$

Using Eq. (A-68) in Eq. (A-67),

$$V_R = -V_a \frac{\Delta R}{2L} \quad (\text{A-71})$$

where  $\frac{\Delta R}{2L}$  = Average streamline slope

Also, from using Eq. (A-68)

$$\text{COS } \lambda = \frac{2L}{\sqrt{\Delta R^2 + (2L)^2}} \quad (\text{A-72})$$

Rearranging;

$$\text{COS } \lambda = \frac{L^2}{L^2 + \left(\frac{\Delta R}{2}\right)^2} \quad (\text{A-73})$$



The remaining term used in the calculation of streamline curvature (Section 16-4 of Ref. [5]) is

$$K \frac{\delta R}{L^2}$$

where K is the so called curvature factor. It usually has a value between 4 and 6 and in the program its value is taken to be 5. Having calculated  $\cos\lambda$ ,  $\Delta R$  and  $\delta R$ , the program repeats the solution process. However, the only quantity which is unchanged is the reference mass flow rate  $\dot{m}_{ref}$ . In subroutine STATR the equation of motion is solved, this time accounting for streamline curvature. The same is true in subroutine ROTO2.

The flow path of the program is identical to the section which did not account for streamline curvature. Next, the program computes an average pressure ratio at the rotor outlet using the expression

$$\frac{P_2}{P_{T0}} = \left( \frac{P_2}{P_{T0}} \right)_{\text{STREAMLINE}_1} + \frac{1}{4} \left[ \left( \frac{P_2}{P_{T0}} \right)_{\text{S.L.}_2} + \left( \frac{P_2}{P_{T0}} \right)_{\text{S.L.}_3} + \left( \frac{P_2}{P_{T0}} \right)_{\text{S.L.}_4} + \left( \frac{P_2}{P_{T0}} \right)_{\text{S.L.}_5} \right]$$

(A-74)

If this pressure ratio is within a specified tolerance to the actual pressure ratio (which is input data) the program



proceeds to the final stage of the calculations. If not, the inlet mach number is adjusted by an amount which depends on the difference between the calculated and specified pressure ratios. If the calculated pressure ratio is too high, the Mach number is lowered using

$$M_o = M_o - \frac{\text{Pressure Ratio Difference}}{18} \quad (\text{A-75})$$

If the computed pressure ratio is too low, the Mach number is raised using

$$M_o = M_o + \frac{\text{Pressure Ratio Difference}}{18} \quad (\text{A-76})$$

In both cases, the program loops back to subroutine CHAN and proceeds to compute a new reference mass flow rate based on the new value of the inlet Mach number. The entire process is then repeated until the pressure ratios agree within the specified tolerance.

#### A-2.11 Final Calculations

Stator and rotor outlet conditions not previously calculated are computed as follows:

$$\alpha_2 = \text{TAN}^{-1} \left[ \frac{V_{u2}}{V_{a2}} \right] \quad (\text{A-77})$$

$$V_2 = \frac{V_{a2}}{\text{COS } \alpha_2} \quad (\text{A-78})$$





$$V_2 = \sqrt{V_2^2 + W_{R2}^2} \quad (\text{A-79})$$

$$\Delta h = \frac{U_1 V_{u1} - U_2 V_{u2}}{g_c J} \quad (\text{A-80})$$

$$T_{T2} = T_{T0} - \frac{\Delta h}{C_p} \quad (\text{A-81})$$

$$P_{T2} = P_2 \left[ \frac{T_{T2}}{T_2} \right]^{\frac{\gamma}{\gamma-1}} \quad (\text{A-82})$$

$$P_{T1} = P_1 \left[ \frac{T_{T0}}{T_1} \right]^{\frac{\gamma}{\gamma-1}} \quad (\text{A-83})$$

$$T_{2,1s} = T_{T0} \left[ \frac{P_2}{P_{T0}} \right]^{\frac{\gamma-1}{\gamma}} \quad (\text{A-84})$$

$$\text{ROTOR EXIT RELATIVE MACH \#} = \frac{W_2}{\sqrt{\gamma R g_c T_2}} \quad (\text{A-85})$$



$$T_{T1s} = T_{T0} \left[ \frac{P_{T2}}{P_{T0}} \right]^{\frac{\gamma-1}{\gamma}} \quad (\text{A-86})$$

$$\eta_{T-T} = \frac{T_{T0} - T_{T2}}{T_{T0} - T_{T1s}} \quad (\text{A-87})$$

$$\eta_{T-S} = \frac{T_{T0} - T_{T2}}{T_{T0} - T_{21s}} \quad (\text{A-88})$$

$$\text{Stator Blade Efficiency} = \frac{T_{T0} - T_1}{T_{T0} - T_{1s}} \quad (\text{A-89})$$

$$\text{Rotor Blade Efficiency} = \frac{T_{T1} - T_2}{T_{T0} - T_{21s}} \quad (\text{A-90})$$

$$r^* = \frac{T_{1s} - T_{21s}}{T_{T0} - T_{21s}} \quad (\text{A-91})$$

$$\text{Head Coefficient} = \frac{2 g_c J (T_{T0} - T_{21s})}{U^2} \quad (\text{A-92})$$

$$\text{Blade-Jet Ratio} = [\text{Head Coefficient}]^{-1} \quad (\text{A-93})$$

$$\text{Stator Exit Relative Mach \#} = \frac{W_1}{\sqrt{\gamma R g_c T_1}} \quad (\text{A-94})$$



The turbine horsepower is obtained by integration. The  $\Delta h$  term at each streamline is weighted by the percentage of mass flow at that streamline. The product is then integrated from hub to tip and result,  $\Delta \bar{h}$ , is used in the turbine horsepower equation

$$H.P. = \frac{\Delta \bar{h} \cdot J \cdot \dot{m}}{550} \quad (A-95)$$

The moment is calculated using

$$M = \frac{(H.P.)(550)}{\omega} \quad (A-96)$$

Referred horsepower, moment, mass flow and RPM are calculated using

$$H.P._{REF} = \frac{H.P.}{\theta \delta} \quad (A-97)$$

$$M_{REF} = \frac{M}{\delta} \quad (A-98)$$

$$\dot{m}_{REF} = \frac{\dot{m} \theta}{\delta} \quad (A-99)$$

$$RPM_{REF} = \frac{RPM}{\theta} \quad (A-100)$$



where

$$\Theta = \frac{T_{T0}}{518.4}$$

$$\delta = \frac{P_{T0}}{14.7}$$

The values of the total-static efficiency, total-total efficiency, total-static pressure ratio, total-total pressure ratio, head coefficient, blade/jet ratio,  $r^*$  and inlet mach number are then averaged.

With all calculations completed, the results are printed under the heading "STATOR SOLUTION", "ROTOR SOLUTION", and "OVERALL TURBINE CHARACTERISTICS".





TABLE A-I

TURBINE GEOMETRIC INPUT DATA (STATOR)  
 (see Figure A-2; Dimensions in inches)

FORTRAN SYMBOL	DESCRIPTION
ZS	Number of blades
RS(1)	Hub radius at stator outlet
RS(3)	Mean radius at stator outlet
RS(5)	Tip radius at stator outlet
C	Blade chord (mean)
CI	Blade chord (hub)
CO	Blade chord (tip)
E	Blade curvature (mean)
EI	Blade curvature (hub)
EO	Blade curvature (tip)
T	Maximum blade thickness (mean)
TI	Maximum blade thickness (hub)
TO	Maximum blade thickness (tip)
TE	Projected T.E. thickness (mean)
TEI	Projected T.E. thickness (hub)
TEO	Projected T.E. thickness (tip)
TN	Normal T.E. thickness (mean)
TNI	Normal T.E. thickness (hub)
TNO	Normal T.E. thickness (tip)
A1(1-10)	Ten values of throat diameter at 10 equally spaced radii



FORTTRAN SYMBOL	DESCRIPTION
AL	Blade camber line length (mean)
ALI	Blade camber line length (hub)
ALO	Blade camber line length (tip)
RC(1)	Hub radius at stator inlet
RC(3)	Mean radius at stator inlet
RC(5)	Tip radius at stator inlet



TABLE A-II

TURBINE GEOMETRIC INPUT DATA (ROTOR)  
 (see Figure A-2; Dimensions in inches)

FORTRAN SYMBOL	DESCRIPTION
ZR	Number of blades
RR(1)	Hub radius
RR(3)	Mean radius
RR(5)	Tip radius
CR	Blade chord (mean)
CIR	Blade chord (hub)
COR	Blade chord (tip)
ER	Blade curvature (mean)
EIR	Blade curvature (hub)
EOR	Blade curvature (tip)
TR	Maximum blade thickness (mean)
TIR	Maximum blade thickness (hub)
TOR	Maximum blade thickness (tip)
TER	Projected T.E. thickness (mean)
TEIR	Projected T.E. thickness (hub)
TEOR	Projected T.E. thickness (tip)
TNR	Normal T.E. thickness (mean)
TNIR	Normal T.E. thickness (hub)
TNOR	Normal T.E. thickness (tip)
TIPC	Tip clearance



FORTRAN SYMBOL	DESCRIPTION
A2(1-10)	10 values of throat diameter at 10 equally spaced radii
ALR	Blade camber line length (mean)
ALIR	Blade camber line length (hub)
ALOR	Blade camber line length (tip)
CV	Axial distance between stations
CK	Curvature Factor





TABLE A-III

TURBINE OPERATING CONDITIONS (INPUT DATA)

<u>FORTTRAN SYMBOL</u>	<u>DESCRIPTION</u>
AMC	Assumed inlet Mach number
AMS	Assumed stator exit Mach number (absolute)
AMR	Assumed stator exit Mach number (relative)
PTO	Total inlet pressure ( $P_{T0}$ )
TTO	Total inlet temperature ( $T_{T0}$ )
PR	Total-static pressure ratio
RPM	Operating speed (RPM)
VA1(3)	Assumed axial velocity in stator
VA2(3)	Assumed axial velocity in rotor



TABLE A-IV

SPECIAL INPUT DATA

<u>FORTRAN SYMBOL</u>	<u>DESCRIPTION</u>
TOL 1	Tolerance for convergence of equation of continuity
TOL 2	Tolerance for between-S.L. continuity (not used)
TOL 3	Tolerance in pressure ratio convergence
TOL 4	Tolerance in equation of motion convergence



TABLE A-V

PROGRAM CONTROL PARAMETERS

FORTRAN SYMBOL	POSSIBLE VALUE	EFFECT/MEANING
IND	1	Prints results in sub-routines STATR, FLOWR, ROTO2
	1	No printing in the above
ICL	1	Rotor is shrouded
	1	Rotor not shrouded
ICOZ	1	$\xi = \xi_0$
	6	$\xi = \xi$ (Y Pressure Ratio)
	8	$\xi = \xi_{M=.8}$
ICON	1	$\xi = .5 \xi_{TOTAL}$
	2	$\xi = \xi_{PROFILE}$
	3	$\xi = \xi_{TOTAL}$



TABLE A-VI

FORTRAN SYMBOLS IN THE MAIN PROGRAM

FORTRAN SYMBOLS	DESCRIPTION
BESP	$\beta^* = [1 + \frac{\gamma-1}{2} \cdot (.8)^2] \frac{\gamma-1}{\gamma}$
OI	Stator throat opening (hub)
OO	Stator throat opening (tip)
OIR	Rotor throat opening (hub)
OOR	Rotor throat opening (tip)
O	Stator throat opening (mean)
OR	Rotor throat opening (mean)
ANG2I	Stator gas outlet angle (hub)
ANG2O	Stator gas outlet angle (tip)
BETAI	Rotor gas outlet angle (hub)
BETAZ	Rotor gas outlet angle (tip)
G	Grav. constant, 32.174 $\frac{\text{FT.LBM}}{\text{LBF.sec}^2}$
CJ	778.16 FT.LBF/BTU
EXP1	$\frac{\gamma}{\gamma} - 1$
EXP2	$\frac{\gamma-1}{\gamma}$
ERRE	Gas constant, 53.3459 $\frac{\text{FT.LBF}}{\text{LBM.or}}$
EMME	Molecular mass, 28.970 LBM/LB MOLE
GAM	$\gamma$ , Ratio of specific heats
ETAT	Total-total efficiency
ETAI	Total-static efficiency
ETAS	Stator blade efficiency





FORTRAN SYMBOL	DESCRIPTION
ETAR	Rotor blade efficiency
RSTAR	Theoretical degree of reaction
ALOS	Head coefficient
BLAJE	Blade/jet ratio
DR1	Radial shift of steamlines
AMW1	Stator exit relative Mach Number
AMS1	Stator exit absolute Mach Number
AMV2	Rotor exit absolute Mach Number
AMR2	Rotor exit relative Mach Number
DELH	$\Delta$
HP	Horsepower
AMOM	Moment
THETA	$\theta$
DELTA	$\delta$
HP1	Referred H.P.
AMOM1	Referred moment
RPM1	Referred RPM
WLBM1	Referred mass flow rate
ETA5	Average total-static efficiency
BETA6	Average total-total pressure ratio
ETA6	Average total-total efficiency
AKIS5	Average head coefficient
RSTAR5	Average theoretical degree of reaction



TABLE A-VII

FORTRAN SYMBOLS IN SUBROUTINE CHAN

FORTRAN SYMBOLS	DESCRIPTION
TTO	$T_{TO}$ , total temp. at station $\emptyset$
AMC	Inlet Mach number
PTO	$P_{TO}$ , total pressure at station $\emptyset$
RC (I)	Streamline radii at station $\emptyset$
WLBM	$\dot{M}$ , required mass flow, $\rho AV$
TC	Static temperature
VC	Velocity
PC	Static pressure
RHO	$\rho$ , density of air
WCHAN	$\dot{M}_{REF}$ , reference mass flow
WPERO	% of $\dot{M}$ at each streamline



TABLE A-VIII

FORTTRAN SYMBOLS IN SUBROUTINE STATR

FORTTRAN SYMBOL	DESCRIPTION
ALFA1	Stator gas outlet angle
X	Ratio of streamline radius/ mean radius
AMS	Mach Number at station 1
T	Static temperature
P	Static pressure
V1	Absolute velocity
VA1	Axial velocity
Y	Ratio of axial velocity to mean axial velocity
S	Entropy
DSDX	Entropy gradient between streamlines
VU1	Tangential velocity
PRAT	(Total-static pressure ratio) <sup>-1</sup>
T1IS	$T_{1IS}$
DALF	$\frac{d\alpha}{dx}$
RSF	Mean stator radius
DELR	$R_{\text{Stator in}} - R_{\text{rotor out}}$
ZETAPS	$\xi_p$
ZETAS	$\xi_s$
VR1	Radial velocity



TABLE A-IX

FORTTRAN SYMBOLS IN SUBROUTINE TRAU2

FORTTRAN SYMBOL	DESCRIPTION
CSIP	$X_p$ , correction to
R	$\xi_{po}$ , initial profile loss coefficient
ANG1	Gas outlet angle
ANG2	Gas inlet angle
R1	$X_m$ , Mach No. correction
R3	$\xi_R$ , remaining loss coefficient
R2	loss coefficient due to wall $\xi_W$ , friction
RPRO	$\xi_p$ , total profile loss coefficient
CL	Rotor tip clearance
YCL	Tip clearance loss coefficient
RTOT	Total loss coefficient
T	Blade spacing
DEZ	Normal trailing edge thickness
HM	Blade height
CSID	$X_\delta$ , trailing edge thickness correction factor
PSID	$\xi_f$ , loss coefficient due to fan losses
PSIF	$\xi_m$ , loss coefficient due to mixing and separation
UM	Tip speed





TABLE A-X

FORTTRAN SYMBOLS IN SUBROUTINE FLOWR

FORTTRAN SYMBOL	DESCRIPTION
PRATCR	Critical pressure ratio
PHICR	$\Phi_{\text{CRIT}}$ , critical flow function
HSTAR	H***, energy parameter
XI	Z, area reduction coefficient
PHI	$\phi$ , flow function (unchoked flow)
ARAT	Streamline throat DIA/mean throat DIA
SUM 1,2,3,4	Successive values of the flow integral
AS	Mean stator throat diameter
AR	Mean rotor throat diameter
WREQ	$\dot{M}$ required to satisfy continuity
WSUM	$\dot{M}$ calculated
WPER	% of $\dot{M}$ at each streamline



TABLE A-XI

FORTRAN SYMBOLS IN SUBROUTINE ROT01

FORTRAN SYMBOL	DESCRIPTION
OMEG.	$\omega$ , wheel speed (RAD/sec)
U	$\omega \cdot R_{\text{stator mean}}$
U2	$\omega \cdot \frac{R_{\text{rotor mean}}}{R_{\text{stator mean}}}$
WU1	$W_{\mu 1}$ see figure A-3
BETA1	$\beta_1$ , see figure A-3
W1	$W_1$ , see figure A-3
TTE	Equivalent temperature
PTE	Equivalent pressure
HE	Equivalent enthalpy
ZETAR	$\xi_R$ rotor loss coefficient
ZETAPR	$\xi_p$ , rotor profile loss coefficient
DHEDX	Enthalpy gradient between streamlines
DSDX	Entropy gradient between streamlines



TABLE A-XII

FORTRAN SYMBOLS IN SUBROUTINE ROTO2

FORTRAN SYMBOL	DESCRIPTION
BETA2	$\beta_2$ , see figure A-3
DBETDX	$\frac{d\beta}{dx}$ between adjacent streamlines
VA2	$V_{a_2}$ , axial velocity
W2	$W_2$ , see figure A-3
CL	Axial distance between stations
WR2	Radial component of velocity
WU2	$Wu_2$ , see figure A-3
VU2	$Vu_2$ , see figure A-3
AMR	Relative Mach No. at rotor exit
T2	$T_2$
T2S	$T_{2s}$
P2	$P_2$
PRAT2	[Total-static pressure ratio] <sup>-1</sup>



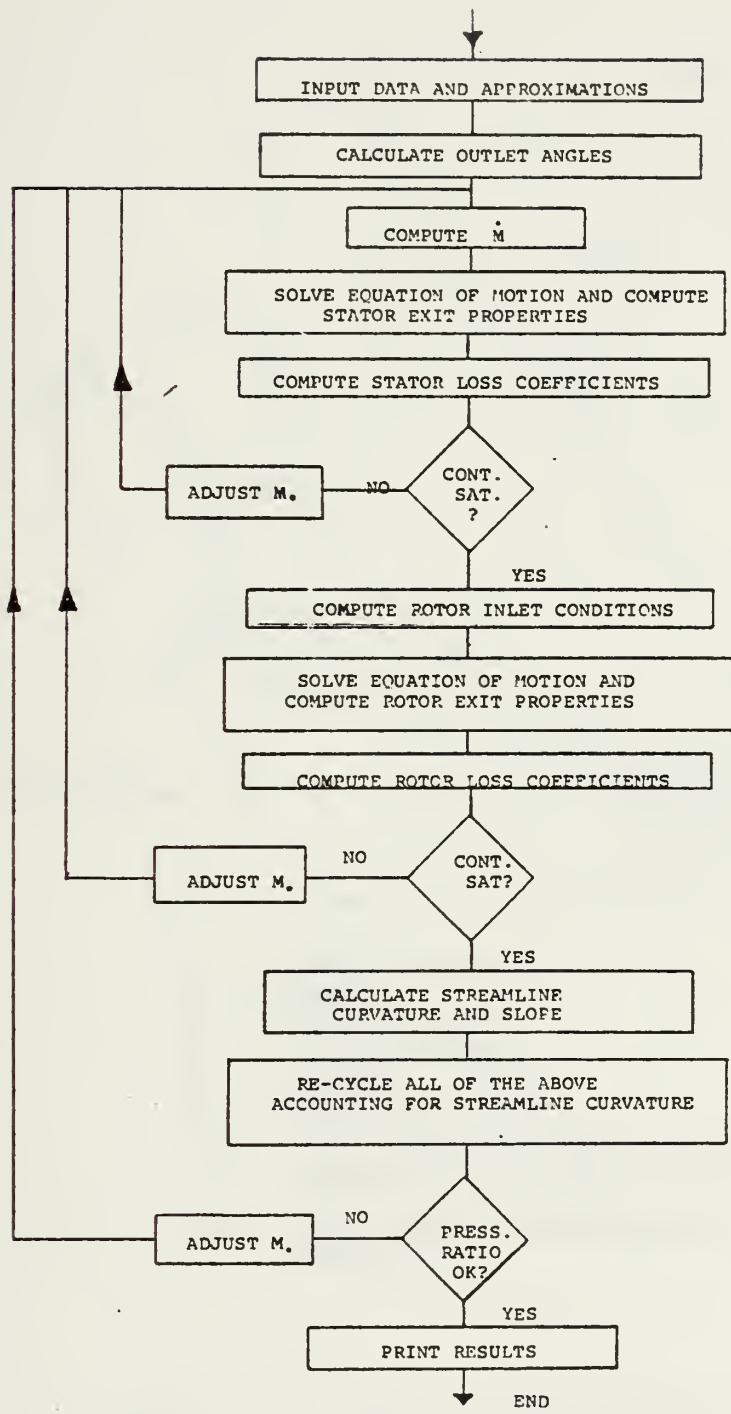
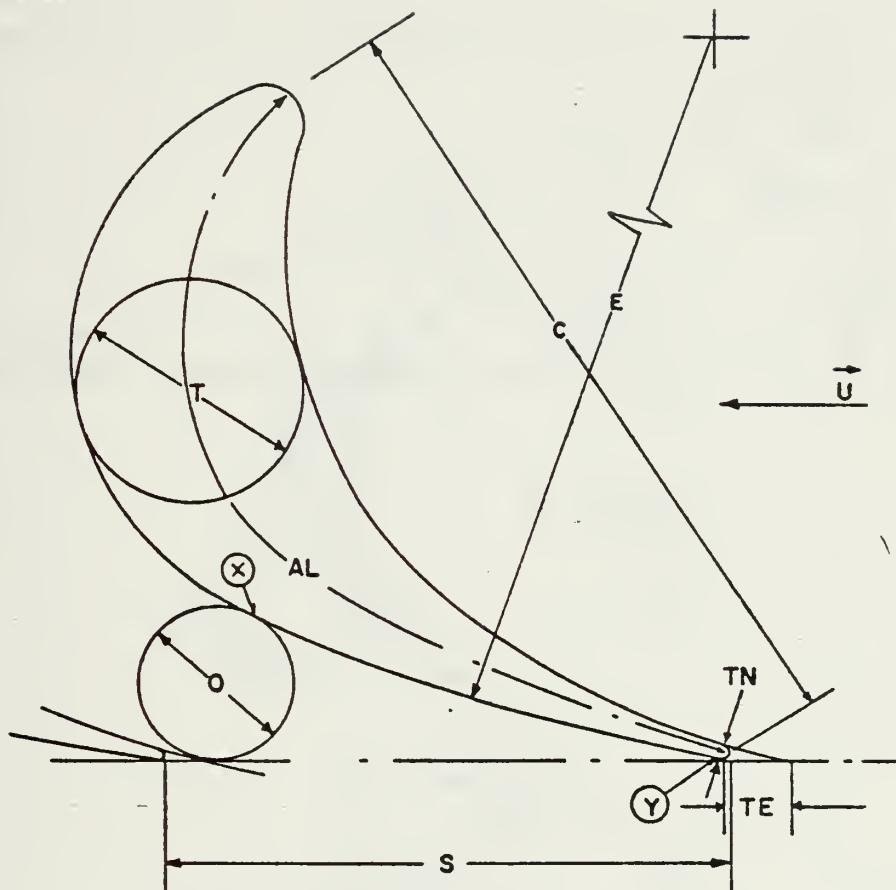

FIGURE A-1: PROGRAM FLOWCHART







- AL = CAMBER LINE LENGTH
- C = CHORD
- O = THROAT DIAMETER
- E = CURVATURE RADIUS
- S = SPACING
- T = MAXIMUM THICKNESS
- TE = TRAILING EDGE THICKNESS PROJECTED IN PERIPHERAL DIRECTION
- TN = TRAILING EDGE THICKNESS, NORMAL TO FLOW DIRECTION

FIGURE A-2: BLADE NOMENCLATURE



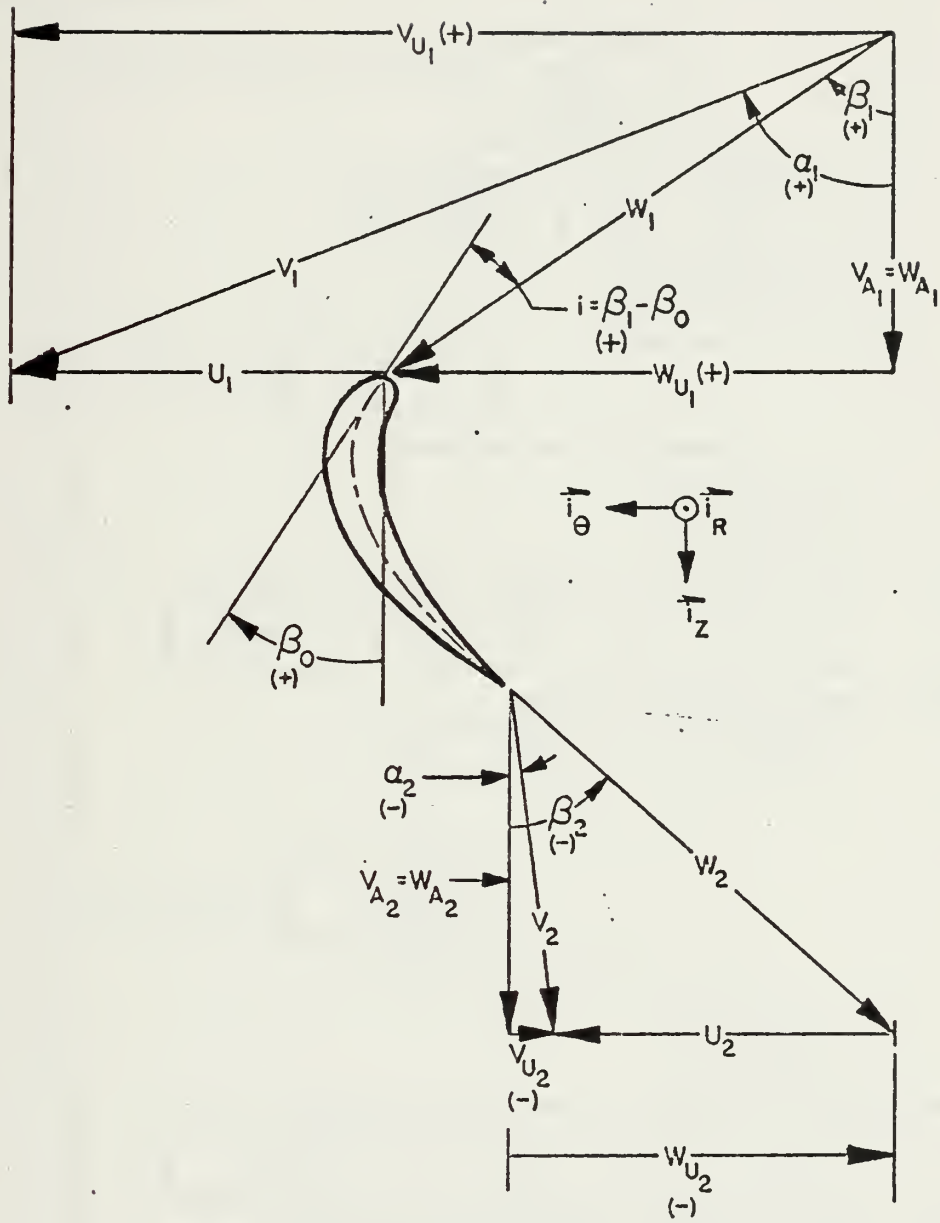

FIGURE A-3: VELOCITY DIAGRAM NOMENCLATURE



MAIN PROGRAM

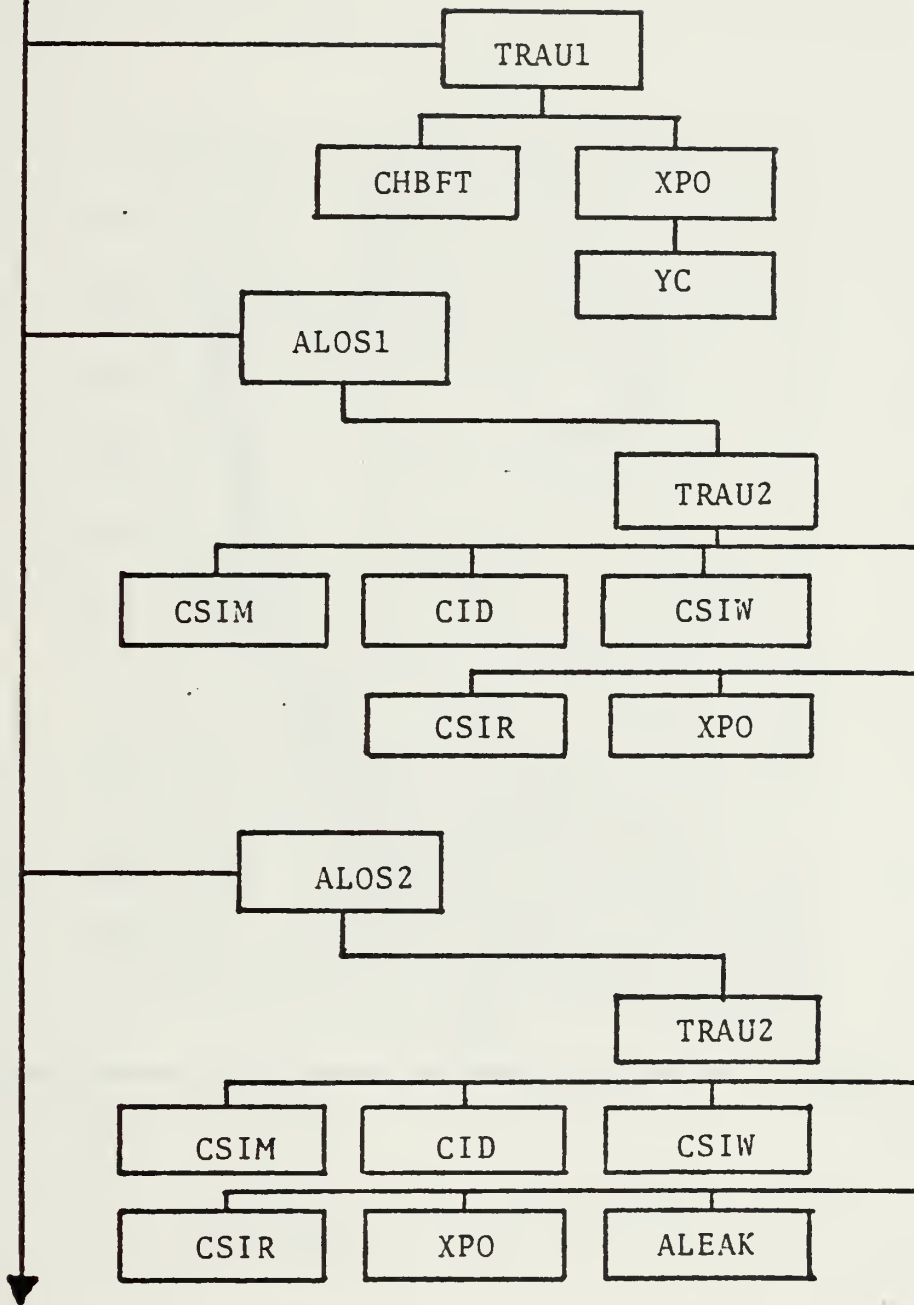

FIGURE A-4: INTERCONNECTION OF THE SUBROUTINES IN THE TRAUPEL METHOD





Abb. 8.4.2 Grundwert  $\zeta_{p0}$  des Profilverlustes für Beschleunigungsgitter und Machzahlkorrektur  $X_M$

FIGURE A-5: INITIAL PROFILE LOSS COEFFICIENT AND MACH NUMBER CORRECTION FROM TRAUPEL





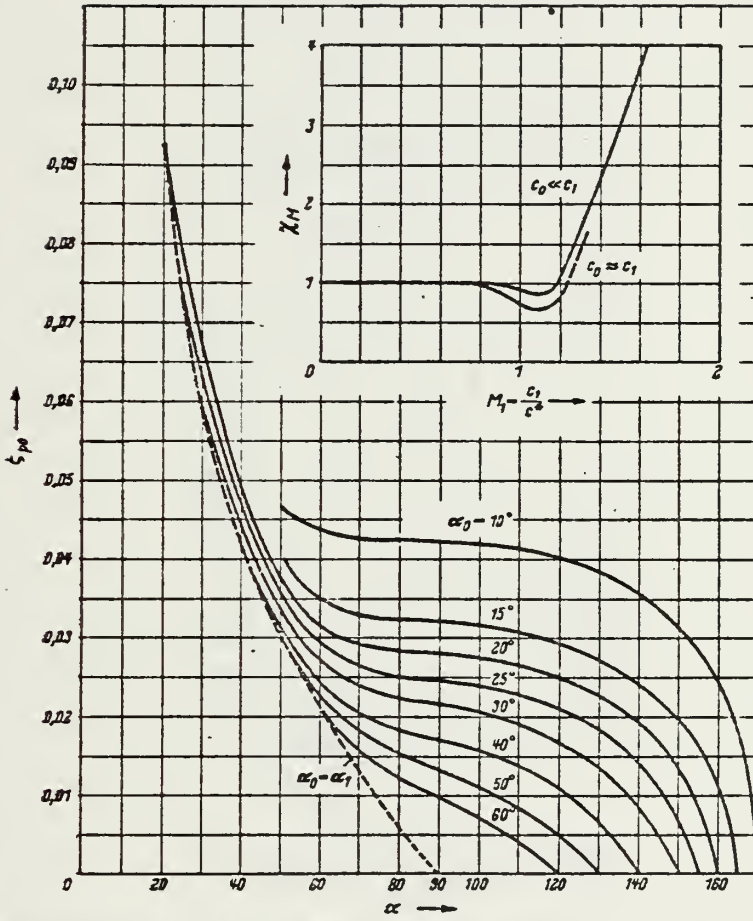

Abb. 8.4.4. Korrekturfaktor  $\chi_\delta$  und Mischverlust  $\zeta_m$  infolge endlicher Austrittskantendicke oder Ablösung



Abb. 8.4.5 Fächerverlust  $\zeta_f$

FIGURE A-6: T.E. THICKNESS CORRECTION FACTOR, MIXING LOSS COEFFICIENT AND FAN LOSS COEFFICIENT FROM TRAUPEL

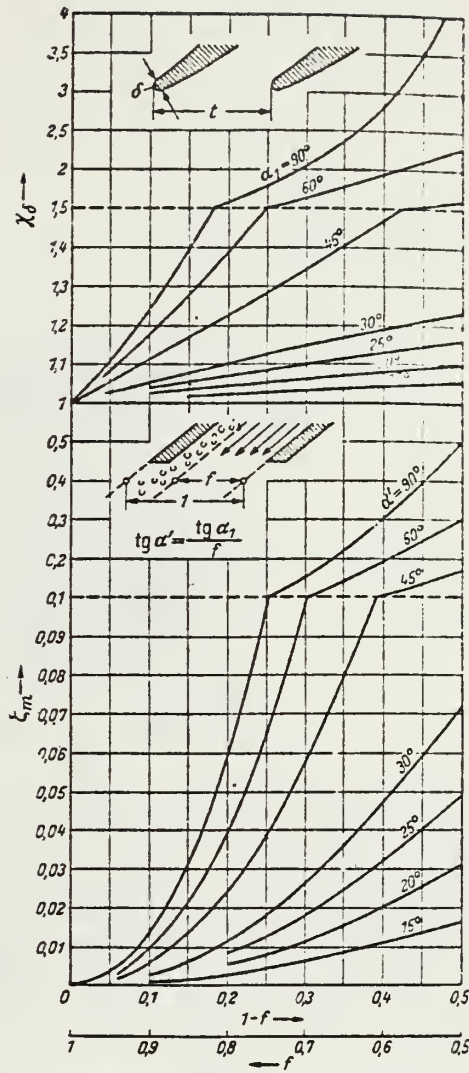

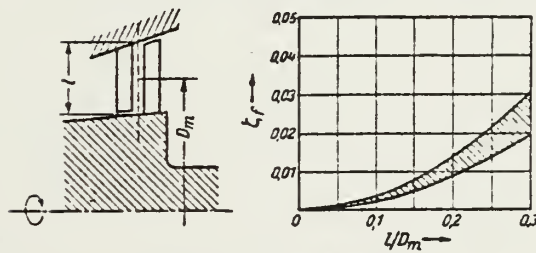

Abb. 8.4.7 Randverlust in Turbinenschaufelungen

FIGURE A-7: "REMAINING" LOSS COEFFICIENT FROM TRAUPEL



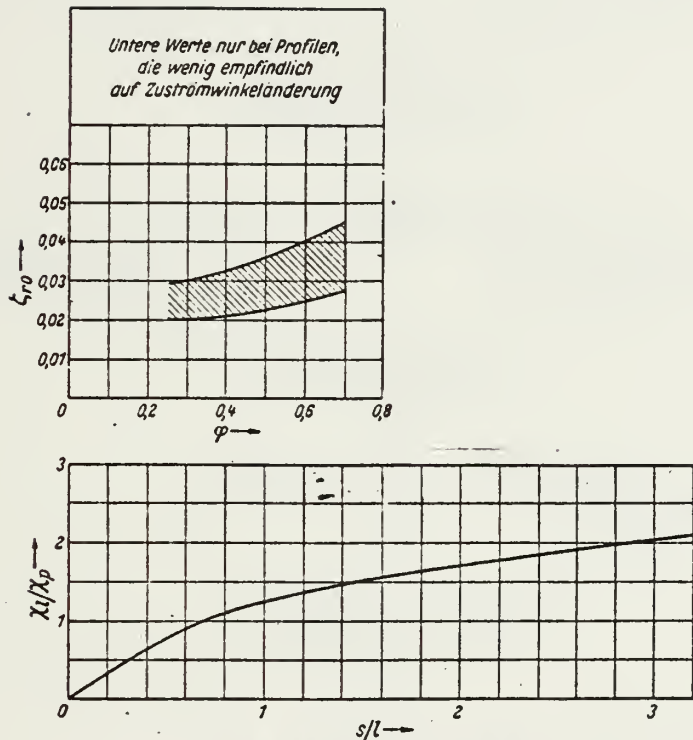
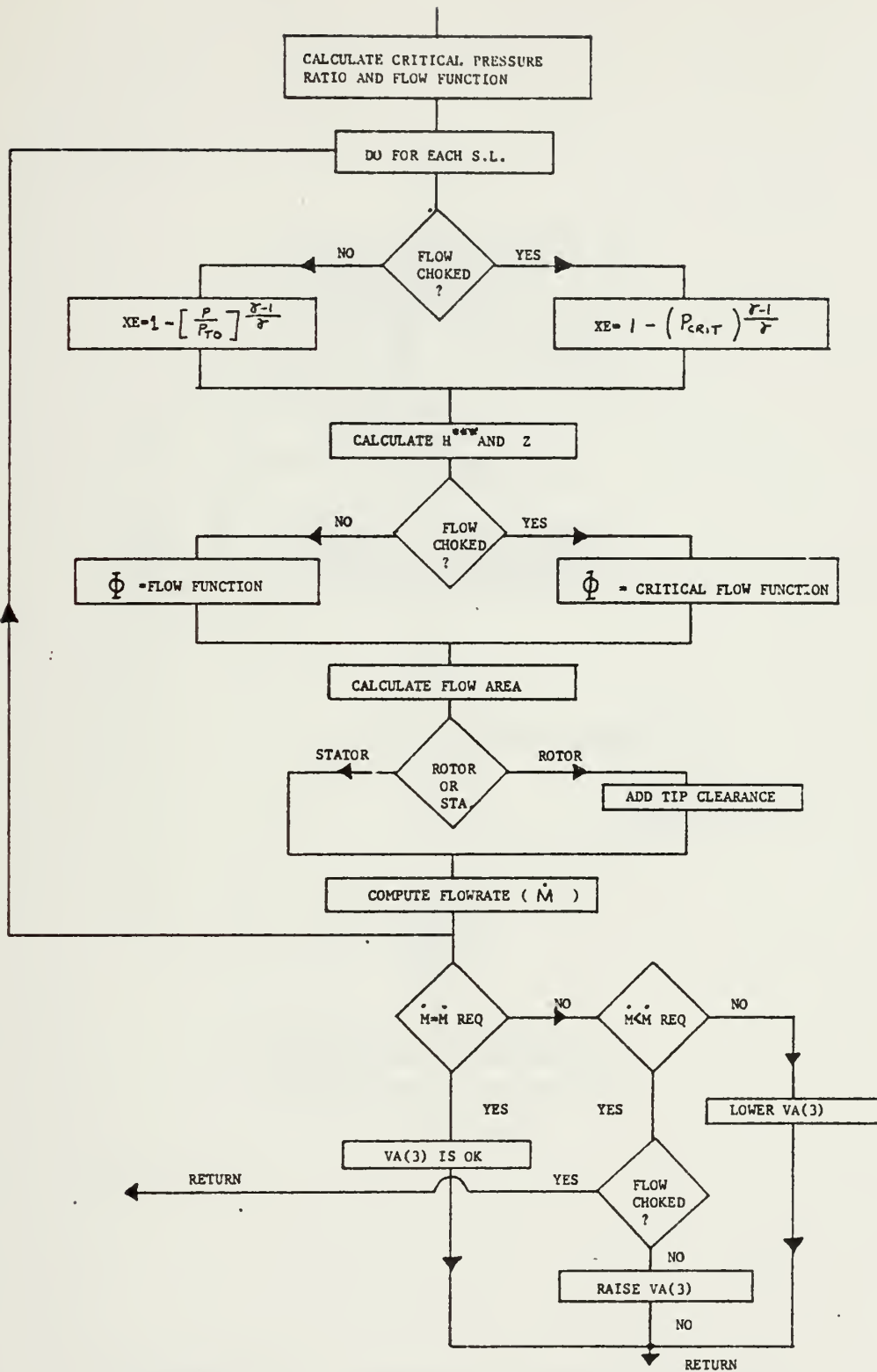

FIGURE A-8: SUBROUTINE FLOWR FLOWCHART



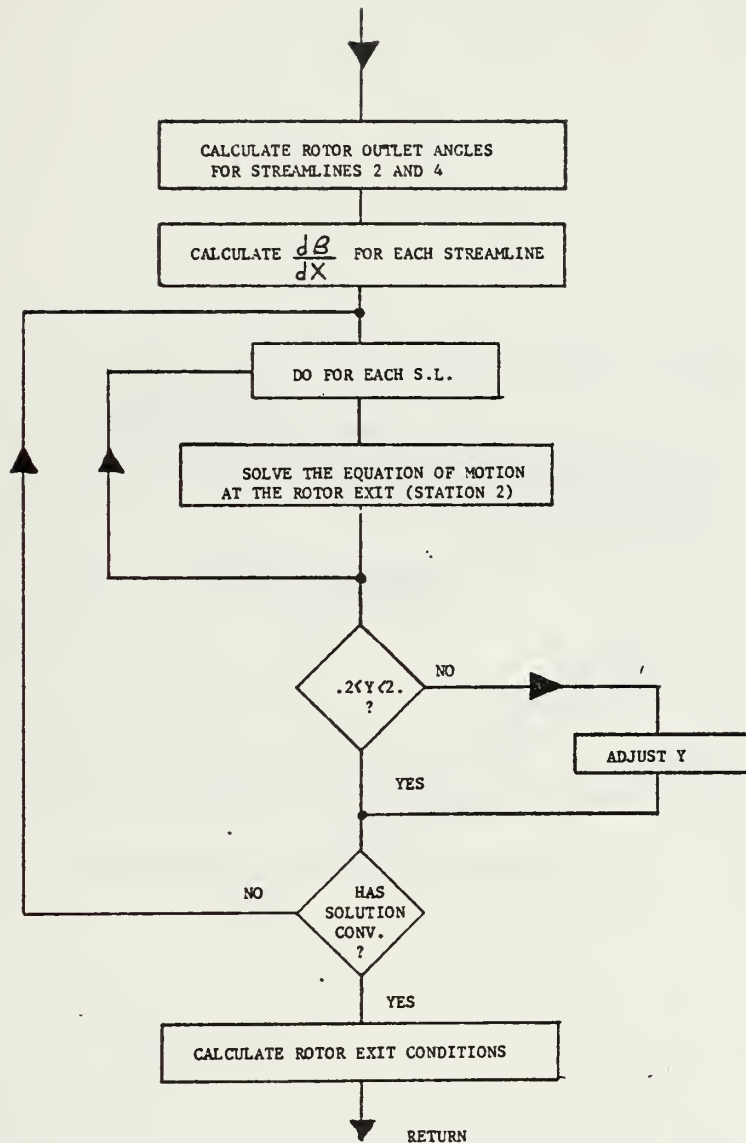

FIGURE A-9: SUBROUTINE ROTO2 FLOWCHART







Abb. 8.4.11 Faktor  $K_I$  für Spaltverlustberechnung

FIGURE A-10: TIP LEAKAGE LOSS COEFFICIENT PLOT FROM TRAUPEL



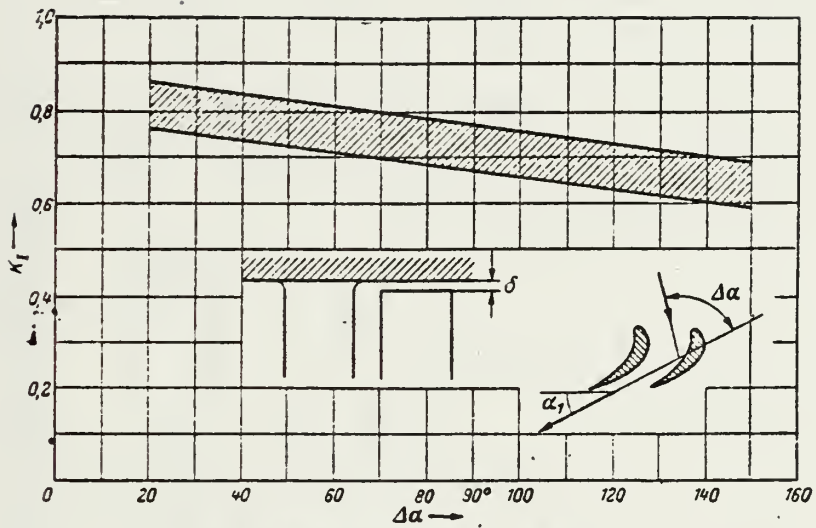
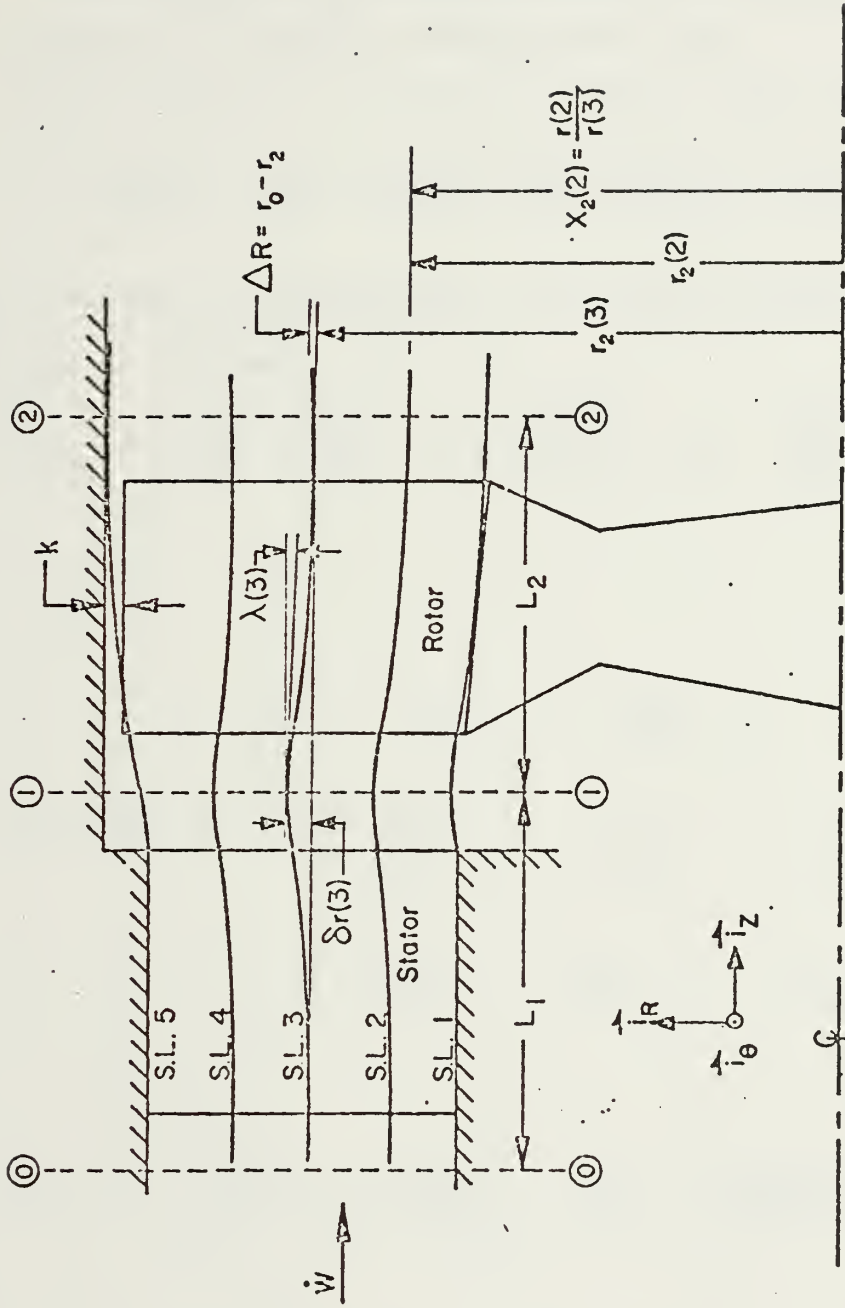

FIGURE A-11: STREAMLINE COORDINATES



APPENDIX: B

DERIVATION OF EQUATIONS USED IN THE PROGRAM

B-1. EQUATION OF MOTION FOR RELATIVE FLOW:

The equation of motion for relative flow Ref. [5] is

$$\nabla H_R = \vec{W} \times (\nabla \times \vec{W} + 2\vec{\omega}) + T \nabla S \quad (B-1)$$

Using cylindrical coordinates, the terms of EQN (B-1) may be expressed as follows:

$$\nabla H_R = \frac{i_\theta}{r} \frac{\partial H_R}{\partial \theta} + i_z \frac{\partial H_R}{\partial z} + i_r \frac{\partial H_R}{\partial r} \quad (B-2)$$

$$\nabla \times \vec{W} = \begin{vmatrix} i_\theta & \frac{i_z}{r} & \frac{i_r}{r} \\ \frac{\partial}{\partial \theta} & \frac{\partial}{\partial z} & \frac{\partial}{\partial r} \\ rW_u & W_a & W_r \end{vmatrix}$$

$$= i_\theta \left[ \frac{\partial W_r}{\partial z} - \frac{\partial W_a}{\partial r} \right] + \frac{i_z}{r} \left[ \frac{\partial (rW_u)}{\partial r} - \frac{\partial W_r}{\partial \theta} \right] + \frac{i_r}{r} \left[ \frac{\partial W_a}{\partial \theta} - \frac{\partial (rW_u)}{\partial z} \right] \quad (B-3)$$



$$\vec{W} \times (\nabla \times \vec{W}) =$$

$$\begin{aligned}
 & \left[ \begin{array}{ccc} i_\theta & i_z & i_r \\ W_u & W_a & W_r \\ \left[ \frac{\partial W_r}{\partial z} - \frac{\partial W_a}{\partial r} \right] & \frac{1}{r} \left[ \frac{\partial(rW_u)}{\partial r} - \frac{\partial W_r}{\partial \theta} \right] & \frac{1}{r} \left[ \frac{\partial W_a}{\partial \theta} - \frac{\partial(rW_u)}{\partial z} \right] \end{array} \right] \\
 & = i_\theta \left[ W_a \frac{1}{r} \left( \frac{\partial W_a}{\partial \theta} - \frac{\partial(rW_u)}{\partial z} \right) - W_r \frac{1}{r} \left( \frac{\partial(rW_u)}{\partial r} - \frac{\partial W_r}{\partial \theta} \right) \right] + \\
 & i_z \left[ W_r \left( \frac{\partial W_r}{\partial z} - \frac{\partial W_a}{\partial r} \right) - W_u \frac{1}{r} \left( \frac{\partial W_a}{\partial \theta} - \frac{\partial(rW_u)}{\partial z} \right) \right] + \\
 & i_r \left[ W_u \frac{1}{r} \left( \frac{\partial(rW_u)}{\partial r} - \frac{\partial W_r}{\partial \theta} \right) - W_a \left( \frac{\partial W_r}{\partial z} - \frac{\partial W_a}{\partial r} \right) \right]
 \end{aligned}$$

(B-4)

$$\vec{W} \times 2\vec{W} = \left[ i_\theta W_u + i_z W_a + i_r W_r \right] \times \left[ i_z 2\omega \right]$$

$$= i_r (2\omega W_u) - i_\theta (2\omega W_r)$$

(B-5)





$$T \nabla S = T \left[ i_{\theta} \frac{1}{r} \frac{\partial S}{\partial \theta} + i_z \frac{\partial S}{\partial z} + i_r \frac{\partial S}{\partial r} \right] \quad (\text{B-6})$$

Combining equations (B-1) through (B-6) the terms in (B-2) can be written as:

$$\begin{aligned} \frac{1}{r} \frac{\partial H_R}{\partial \theta} &= \frac{W_a}{r} \left[ \frac{\partial W_a}{\partial \theta} - \frac{\partial (r W_u)}{\partial z} \right] - \\ &\frac{W_r}{r} \cdot \left[ \frac{\partial (r W_u)}{\partial r} - \frac{\partial W_r}{\partial \theta} \right] - 2 \omega W_r + \frac{T}{r} \frac{\partial S}{\partial \theta} \end{aligned} \quad (\text{B-7})$$

$$\begin{aligned} \frac{\partial H_R}{\partial z} &= W_r \left[ \frac{\partial W_r}{\partial z} - \frac{\partial W_a}{\partial r} \right] - \frac{W_u}{r} \left[ \frac{\partial W_a}{\partial \theta} - \right. \\ &\left. \frac{\partial (r W_u)}{\partial z} \right] + T \frac{\partial S}{\partial z} \end{aligned} \quad (\text{B-8})$$

$$\begin{aligned} \frac{\partial H_R}{\partial r} &= \frac{W_u}{r} \left[ \frac{\partial (r W_u)}{\partial r} - \frac{\partial W_r}{\partial \theta} \right] - \\ &W_a \left[ \frac{\partial W_r}{\partial z} - \frac{\partial W_a}{\partial r} \right] + 2 \omega W_u + T \frac{\partial S}{\partial r} \end{aligned}$$

(B-9)



Since the flow has been assumed to be axisymmetric, all derivatives with respect to  $\theta$  are zero. Thus, Equations (B-7), (B-8) and (B-9) reduce to, respectively:

$$0 = - \frac{W_a}{r} \frac{\partial(rW_u)}{\partial z} - \frac{W_r}{r} \frac{\partial(rW_u)}{\partial r} - 2\omega W_r \quad (\text{B-10})$$

$$\frac{\partial H_R}{\partial z} = W_r \frac{\partial W_r}{\partial z} - W_r \frac{\partial W_a}{\partial r} + \frac{W_u}{r} \cdot$$

$$\frac{\partial(rW_u)}{\partial z} + T \cdot \frac{\partial s}{\partial z} \quad (\text{B-11})$$

$$\frac{\partial H_R}{\partial r} = \frac{W_u}{r} \frac{\partial(rW_u)}{\partial r} - W_a \frac{\partial W_r}{\partial z} + W_a \frac{\partial W_a}{\partial r} +$$

$$2\omega W_u + T \frac{\partial s}{\partial r} \quad (\text{B-12})$$

Equation (B-10) may be written as

$$\frac{\partial(rW_u)}{\partial z} = - \frac{W_r}{W_a} \frac{\partial(rW_u)}{\partial r} - 2\omega r \frac{W_r}{W_a} \quad (\text{B-13})$$

Substituting into equation (B-11),

$$\frac{\partial H_R}{\partial z} = - \frac{W_u}{r} \frac{W_r}{W_a} \frac{\partial(rW_u)}{\partial r} + W_r \frac{\partial W_r}{\partial z} -$$

$$W_r \frac{\partial W_a}{\partial r} - 2\omega \frac{W_u W_r}{W_a} - T \frac{\partial s}{\partial z} \quad (\text{B-14})$$



Multiplying equation (B-9) by  $W_r$  and Equation (B-14) by  $W_a$  results in

$$W_r \frac{\partial H_R}{\partial r} = \frac{W_u W_r}{r} \frac{\partial (r W_u)}{\partial r} - W_a W_r \frac{\partial W_r}{\partial z} +$$

$$W_a W_r \frac{\partial W_a}{\partial r} + 2 \omega W_u W_r + W_r T \frac{\partial S}{\partial r} \quad (\text{B-15})$$

and

$$W_a \frac{\partial H_R}{\partial z} = - \frac{W_u W_r}{r} \frac{\partial (r W_u)}{\partial r} + W_a W_r \frac{\partial W_r}{\partial z} -$$

$$W_a W_r \frac{\partial W_a}{\partial r} - 2 \omega W_u W_r + W_a T \frac{\partial S}{\partial z} \quad (\text{B-16})$$

Adding these two equations yields

$$W_r \frac{\partial H_R}{\partial r} + W_a \frac{\partial H_R}{\partial z} = T \left[ W_r \frac{\partial S}{\partial r} + W_a \frac{\partial S}{\partial z} \right] \quad (\text{B-17})$$

Since the flow has been assumed to be adiabatic, the total relative enthalpy,  $H_R$ , is constant along a streamline. Thus,

$$\nabla H_R = 0 = W_a \frac{\partial H_R}{\partial z} + W_r \frac{\partial H_R}{\partial r} \quad (\text{B-18})$$

and re-arranging,

$$\frac{\partial H_R}{\partial z} = - \frac{W_r}{W_a} \frac{\partial H_R}{\partial r} \quad (\text{B-19})$$

From equation (B-19), eq. (B-17) can be written as

$$\frac{\partial S}{\partial z} = - \frac{W_r}{W_a} \frac{\partial S}{\partial r} \quad (\text{B-20})$$



Substituting Eq.s (B-19) and (B-20) into equation (B-15) gives

$$-\frac{W_r}{W_a} \frac{\partial H_R}{\partial r} = -\frac{W_{uu}}{r} \frac{W_r}{W_a} \frac{\partial (r W_{uu})}{\partial r} + W_r \frac{\partial W_r}{\partial z} - W_r \frac{\partial W_a}{\partial r} - 2\omega \frac{W_{uu} W_r}{W_a} - \frac{W_r}{W_a} T \frac{\partial S}{\partial r} \quad (B-21)$$

Multiplying Equation (B-21) by  $\frac{-W_a}{W_r}$  yields

$$\frac{\partial H_R}{\partial r} = \frac{W_{uu}}{r} \frac{\partial (r W_{uu})}{\partial r} - W_a \frac{\partial W_r}{\partial z} + W_a \frac{\partial W_a}{\partial r} + 2\omega W_{uu} + T \frac{\partial S}{\partial r} \quad (B-22)$$

This expression is identical to equation (B-21) and is the equation which must be solved. It must be put into a form which can be solved by the computer. Re-writing equation (B-22) given that

$$W_a \frac{\partial W_a}{\partial r} = \frac{1}{2} \frac{\partial (W_a^2)}{\partial r}$$

yields

$$\frac{\partial (W_a^2)}{\partial r} - 2W_a \frac{\partial W_r}{\partial z} + \frac{2W_{uu}}{r} \frac{\partial (r W_{uu})}{\partial r} + 4\omega W_{uu} - 2 \frac{\partial H_R}{\partial r} + 2T \frac{\partial S}{\partial r} = 0 \quad (B-23)$$

The relative enthalpy can be written

$$H_R = h_1 + \frac{W_1^2}{2g_c J} - \frac{U_1^2}{2g_c J} = h_2 + \frac{W_2^2}{2g_c J} - \frac{U_2^2}{2g_c J} \quad (B-24)$$





The equivalent enthalpy, defined in ref. [1] is

$$H_E = h_1 + \frac{W_1^2}{2g_c J} + \frac{U_2^2 - U_1^2}{2g_c J} \quad (\text{B-25})$$

Hence, the relative enthalpy can be written as

$$H_R = H_E - \frac{U_2^2}{2} \quad (\text{B-26})$$

Also, the turbine outlet static temperature can be written as

$$T_2 = \frac{H_E}{C_p} - \frac{W_2^2}{2C_p} \quad (\text{B-27})$$

Substituting Eq. (B-26) and Eq. (B-27) into Eq. (B-23) and applying Eq. (B-21) to the rotor exit, gives

$$\begin{aligned} & \frac{\partial(Wa^2)}{\partial r_2} - 2Wa_2 \frac{\partial W r_2}{\partial z} + 2 \frac{W u_2}{r_2} \frac{\partial(r_2 W u_2)}{\partial r_2} + \\ & 4 \omega W u_2 - 2 \frac{\partial}{\partial r_2} \left[ H_E - \frac{U_2^2}{2} \right] + 2 \left[ \frac{H_E}{C_p} - \right. \\ & \left. \frac{W_2^2}{2C_p} \right] \frac{\partial S_2}{\partial r_2} = 0 \end{aligned} \quad (\text{B-28})$$

Given the relationships:

$$T_{AN}^2 \lambda = \frac{W_r^2}{W_a^2}$$



and  $1 + \tan^2 \lambda = \frac{1}{\cos^2 \lambda}$

Equation (B-28) can be written as

$$\begin{aligned} & \frac{\partial (Wa_2^2)}{\partial r_2} - 2Wa_2 \frac{\partial W_{r_2}}{\partial z} - \frac{Wa_2^2}{c_p \cos^2 \lambda_2} \cdot \frac{\partial S_2}{\partial r_2} + 2 \cdot \\ & \frac{Wu_2}{r_2} \cdot \frac{\partial (r_2 Wu_2)}{\partial r_2} + 4\omega Wu_2 - 2 \frac{\partial HE}{\partial r_2} + \\ & \frac{\partial (U_2^2)}{\partial r_2} + \frac{1}{c_p} \left[ 2HE - Wu_2^2 \right] \frac{\partial S_2}{\partial r_2} \end{aligned} \quad (B-29)$$

and substituting  $\frac{\partial (U_2^2)}{\partial r_2} = 2\omega^2 r_2$  into equation (B-29) gives

$$\begin{aligned} & \frac{\partial (Wa_2^2)}{\partial r_2} - 2Wa_2 \frac{\partial W_{r_2}}{\partial z} - \frac{Wa_2^2}{c_p \cos^2 \lambda_2} \frac{\partial S_2}{\partial r_2} - \\ & 2 \frac{Wu_2}{r_2} \frac{\partial (r_2 Wu_2)}{\partial r_2} + 4\omega Wu_2 - 2 \frac{\partial HE}{\partial r_2} + \\ & 2\omega^2 r_2 + \frac{1}{c_p} \left[ 2HE - Wu_2^2 \right] \frac{\partial S_2}{\partial r_2} \end{aligned} \quad (B-30)$$

Multiplying Eq. (B-30) by  $\left(\frac{r_m}{W_{a_m}^2}\right)$  results in the dimension-

less form of Equation (B-29):



$$\begin{aligned}
& \frac{r_{2m}}{W a_{2m}^2} \frac{\partial (W a_2^2)}{\partial r_2} - 2 \frac{W a_2}{W a_{2m}^2} \frac{W a_2}{W a_2} r_{2m} \frac{\partial (W r_2)}{\partial z} - \\
& \frac{W a_2^2 r_{2m}}{W a_{2m}^2 C_p \cos^2 \lambda_2} \frac{\partial S_2}{\partial r_2} + 2 \frac{W u_2 W a_2 r_{2m}}{W a_{2m} W a_2 r_2} \cdot \frac{\partial \left[ \frac{r_2 W u_2 W a_2}{r_{2m} W a_{2m} W a_2} \right]}{\partial (r_2 / r_{2m})} \\
& + 4 \frac{\omega r_{2m} W u_2 W a_2}{W a_{2m}^2 W a_2} - 2 \frac{r_{2m}}{W a_{2m}^2} \frac{\partial H E}{\partial r_2} + \frac{2 \omega^2 r_2 r_{2m}}{W a_{2m}^2} + \\
& \frac{r_{2m}}{C_p} \left[ \frac{\partial H E}{W a_{2m}^2} - \frac{W u_2^2 W a_2^2}{W a_{2m}^2 W a_2^2} \right] \frac{\partial S_2}{\partial r_2}
\end{aligned}$$

(B-31)

Introducing the non-dimensional quantities

$$Y = \frac{W a}{W a_m} \quad (B-32)$$

$$X = \frac{r}{r_m} \quad (B-33)$$

$$S^* = \frac{S}{C_p} \quad (B-34)$$



Equation (B-31) is written as

$$\begin{aligned}
 & \frac{\partial(Y^2)}{\partial X} - 2 \frac{Y^2}{W_a} r_m \frac{\partial W_r}{\partial z} - \frac{Y^2}{\cos^2 \lambda} \frac{\partial S^*}{\partial X} + \\
 & 2Y \frac{\text{TAN} \beta}{X} \frac{\partial(XY \text{TAN} \beta)}{\partial X} + 4 \frac{U_m Y \text{TAN} \beta}{W_{am}} - \\
 & \frac{2}{W_{am}^2} \frac{\partial H_E}{\partial X} + 2 \frac{U_m U_z}{W_{am}^2} + \left[ \frac{2 H_E}{W_{am}^2} - \right. \\
 & \left. Y^2 \text{TAN}^2 \beta \right] \frac{\partial S^*}{\partial X} = 0 \quad (B-35)
 \end{aligned}$$

The fourth term of Eq. (B-35) is

$$\begin{aligned}
 & 2Y \frac{\text{TAN} \beta}{X} \frac{\partial(XY \text{TAN} \beta)}{\partial X} = 2Y \frac{\text{TAN} \beta}{X} \left[ XY \right. \\
 & \left. \frac{\partial \text{TAN} \beta}{\partial X} + X \text{TAN} \beta \frac{\partial Y}{\partial X} + Y \text{TAN} \beta \frac{\partial X}{\partial X} \right] \\
 & = 2Y^2 \text{TAN} \beta \frac{\partial \text{TAN} \beta}{\partial X} + 2Y \text{TAN}^2 \beta \frac{\partial Y}{\partial X} + \\
 & 2 \frac{Y^2}{X} \text{TAN}^2 \beta
 \end{aligned}$$





also,

$$\frac{\partial \text{TAN} \beta}{\partial X} = \frac{1}{\cos^2 \beta} \frac{\partial \beta}{\partial X}$$

and

$$2Y \text{TAN}^2 \beta \frac{\partial Y}{\partial X} = \text{TAN}^2 \beta \frac{\partial (Y^2)}{\partial X}$$

Therefore, equation (B-35) can be written

$$\begin{aligned} & \frac{\partial (Y^2)}{\partial X} (1 + \text{TAN}^2 \beta) - 2 \frac{Y^2}{W_a} r_m \frac{\partial W_r}{\partial z} - \frac{Y^2}{\cos^2 \lambda} \frac{\partial s^*}{\partial X} + \\ & 2Y^2 \frac{\text{TAN} \beta}{\cos^2 \beta} \frac{\partial \beta}{\partial X} + 2 \frac{Y^2}{X} \text{TAN}^2 \beta + \frac{4U_m Y \text{TAN} \beta}{W_{a_m}} - \\ & \frac{2}{W_{a_m}^2} \frac{\partial H_E}{\partial X} + 2 \frac{U_m U_z}{W_{a_m}^2} + \left[ \frac{2H_E}{W_{a_m}^2} - Y^2 \text{TAN}^2 \beta \right] \frac{\partial s^*}{\partial X} \end{aligned}$$

(B-36)

Multiplying Eq. (B-36) by  $\left( \frac{\cos^2 \beta}{Y^2} \right)$  and observing that  $\left( 1 + \text{TAN}^2 \beta = \frac{1}{\cos^2 \beta} \right)$ ,

$$\begin{aligned} & \frac{1}{Y^2} \frac{\partial (Y^2)}{\partial X} + \cos^2 \beta \left[ - \frac{2r_m}{W_a} \frac{\partial W_r}{\partial z} - \frac{1}{\cos^2 \lambda} \frac{\partial s^*}{\partial X} \right] + \\ & 2 \text{TAN} \beta \frac{\partial \beta}{\partial X} + \frac{2}{X} \sin^2 \beta + \frac{4U_m \sin \beta \cos \beta}{W_{a_m} Y} + \frac{2U_m U_z \cos^2 \beta}{W_{a_m}^2 Y^2} \\ & - \frac{2 \cos^2 \beta}{W_{a_m}^2} \frac{\partial H_E}{\partial X} + \left[ \frac{2H_E \cos^2 \beta}{W_{a_m}^2 Y^2} - \sin^2 \beta \right] \frac{\partial s^*}{\partial X} = 0 \end{aligned}$$

(B-37)



To account for streamline curvature the following terms are introduced:

$$\cos^2 \lambda = \frac{L^2}{L^2 + \left(\frac{\Delta R}{2}\right)^2} \quad (\text{B-38})$$

where  $\lambda$ , the angle between the axial and radial components of velocity at a point, is approximated as the average value between two stations.

Also,

$$K \frac{\delta R}{L^2} = - \frac{1}{W_a} \frac{\partial W_r}{\partial z} \quad (\text{B-39})$$

where  $\delta r$  is the streamline shift through the rotor defined as

$$\delta r = r_{\text{ROTOR OUTLET}} - r_{\text{ROTOR INLET}} \quad (\text{B-40})$$

Substituting Eqs. (B-38) and (B-39) into (B-37) yields

$$\begin{aligned} \frac{d(\ln Y^2)}{dx} = & -\cos^2 \beta \left[ -\left(2K r_m \frac{\delta R}{L^2}\right) - \left(\frac{L^2 + (\Delta R)^2}{L^2}\right) \frac{ds^*}{dx} \right] \\ & - 2 \tan \beta \frac{d\beta}{dx} - \frac{2}{x} \sin^2 \beta - \frac{4 U_m \sin \beta \cos \beta}{W_{a_m} Y} - \\ & \frac{2 U_m U_2 \cos^2 \beta}{W_{a_m}^2 Y^2} + \frac{2 \cos^2 \beta}{W_{a_m}^2 Y^2} \frac{dH_E}{dx} - \left[ \frac{2 H_E \cos^2 \beta}{W_{a_m}^2 Y^2} - \sin^2 \beta \right] \frac{ds^*}{dx} \end{aligned} \quad (\text{B-41})$$



To obtain a dimensionless equation, the term

$$C_1 = 2g_c J$$

is introduced into Eq. (B-41) giving

$$\frac{d(\ln Y^2)}{dx} = -\cos^2 \beta \left[ -\left( K \frac{2(\delta r) r_m}{L^2} \right) - \left( \frac{L^2 + (\Delta R)^2}{L^2} \right) \frac{ds^*}{dx} \right] -$$

$$2 \tan \beta \frac{d\beta}{dx} - \frac{2}{x} \sin^2 \beta - \frac{4U_m \sin \beta \cos \beta}{W a_m Y} - \frac{2U_m U_2 \cos^2 \beta}{W a_m^2 Y^2} +$$

$$\frac{C_1 \cos^2 \beta}{W a_m^2 Y^2} \frac{dHe}{dx} - \left[ \frac{C_1 He \cos^2 \beta}{W a_m^2 Y^2} - \sin^2 \beta \right] \frac{ds^*}{dx}$$

(B-42)

Equation (B-42) is the form of equation of motion used in the computer program.

## B-2. EQUATION OF MOTION FOR ABSOLUTE FLOW

The equation of motion for absolute flow

$$\nabla H = \vec{V} \times (\nabla \times \vec{V}) + T \nabla S$$

(B-43)



Differs from the equation of motion for relative flow

$$\nabla H_R = \vec{W} \times (\nabla \times \vec{W} + 2\vec{\omega}) + T \nabla S \quad (\text{B-44})$$

only by the term  $\vec{W} \times 2\vec{\omega}$  which is the Coriolis acceleration.

To obtain the programmed form of the equation of motion for

the stator, the previous derivation is followed, but with

$U = 0$ ,  $H_E$  becomes  $H$ ,  $W$  becomes  $V$ , and  $\beta$  becomes  $\alpha$ .

### B-3 THE AREA RESTRICTION FACTOR Z

The condition at the outlet of a blade row with boundary layers on both sides of the flow channel is shown in Fig. B-1.

The flow is considered to be turbulent within the boundary

layer while, outside the layer, the velocity of the flow is

the theoretical velocity. Assuming a power-law velocity pro-

file, the velocity may be written,

$$\frac{u}{V_{TH}} = \left[ \frac{y}{\delta} \right]^m \quad (\text{B-45})$$

The mass flow rate exiting the blade row can be expressed as

$$\dot{m} = \rho_{TH} V_{TH} \cos \alpha_d \left[ S - \frac{t}{\cos^* \alpha_d} - \frac{\sum \delta}{\cos \alpha_d} \right] + \sum \int_0^{\delta} u \rho dy \quad (\text{B-46})$$

where  $\rho_{th}$  and  $V_{th}$  represent the ideal conditions for an

isentropic expansion through the blade row to the discharge





pressure  $P_d$ , which is assumed to be constant across the blade spacing. The discharge angle of the flow leaving the blade row is closely approximated by the expression [Ref. 1]

$$\alpha_d = \cos^{-1} \left[ \frac{a}{S - \frac{t}{\cos^* \alpha_d}} \right] \quad (\text{B-47})$$

Inserting Eq. (B-47) into (B-46) and reducing yields

$$\dot{m} = \rho_{TH} V_{TH} a \left[ 1 - \sum \frac{\delta}{a} \left( 1 - \int_0^1 \frac{\rho}{\rho_{TH}} \frac{u}{u_{TH}} d\eta \right) \right] \quad (\text{B-48})$$

Assuming a perfect gas

$$\frac{\rho}{\rho_{TH}} = \frac{T_{TH}}{T} = \frac{T_{T0} - (T_{T0} - T_{TH})}{T_{T0} - (T_{T0} - T_{TH}) \left( \frac{u}{V_{TH}} \right)^2} \quad (\text{B-49})$$

Defining

$$X_E = 1 - \left( \frac{P_d}{P_{T0}} \right)^{\frac{\gamma-1}{\gamma}} \quad (\text{B-50})$$

Equation (B-49) can be written

$$\frac{\rho}{\rho_{TH}} = \frac{1 - X_E}{1 - X_E \left( \frac{u}{V_{TH}} \right)^2} \quad (\text{B-51})$$

Substituting Eq. (B-51) into (B-45) yields

$$\dot{m} = \rho_{TH} V_{TH} a \left[ 1 - \sum \frac{\delta}{a} (1 - (1 - X_E) \int_0^1 \frac{\eta^m}{1 - X_E \eta^{2m}} d\eta) \right] \quad (\text{B-52})$$



Using the displacement thickness given by

$$\delta^* = \delta \cdot \left[ 1 - (1 - X_E) \int_0^1 \frac{\eta^m}{(1 - X_E \eta^{2m})} d\eta \right] \quad (\text{B-53})$$

the mass flow rate can be written as

$$\dot{m} = \rho_{TH} V_{TH} a \left[ 1 - \frac{\sum \delta^*}{a} \right] \quad (\text{B-54})$$

The loss coefficient, expressed in terms of average kinetic energy lost is

$$\zeta = \frac{\Delta E}{\dot{m} \left( \frac{V_{TH}^2}{2} \right)} = 1 - \frac{E}{\dot{m} \frac{V_{TH}^2}{2}} \quad (\text{B-55})$$

where E is the actual kinetic energy of the flow, given by

$$E = \rho_{TH} V_{TH} (a - \sum \delta) \frac{V_{TH}^2}{2} + \sum \int_0^\delta \rho u \frac{u^2}{2} dy \quad (\text{B-56})$$

Substituting Eq. (B-51) into (B-56) gives

$$E = \rho_{TH} \frac{V_{TH}^2}{2} a \left[ 1 - \sum \frac{\delta}{a} (1 - (1 - X_E) \int_0^1 \frac{\eta^{3m}}{(1 - X_E \eta^{2m})} d\eta) \right] \quad (\text{B-57})$$



The energy thickness is written as

$$\delta^{***} = \delta \left[ 1 - (1 - X_E) \int_0^1 \frac{1}{(1 - X_E \eta^{2m})^{3m}} d\eta \right] \quad (\text{B-58})$$

The loss coefficient can therefore be written as

$$\xi = 1 - \frac{1 - \sum \frac{\delta^{***}}{a}}{1 - \sum \frac{\delta^*}{a}} \quad (\text{B-59})$$

The area restriction factor  $Z$ , is the fraction of the flow area through which the uniform theoretical velocity would produce the actual flow rate, thus

$$Z = \frac{\sum \delta^*}{a} \quad (\text{B-60})$$

Defining the energy parameter (a form factor) as

$$H^{***} = \frac{\delta^{***}}{\delta^*} \quad (\text{B-61})$$

using Equations (B-59) and (B-61), Eq. (B-60) becomes

$$Z = \frac{H^{***} - 1}{H^{***} - 1 + \xi_P} \quad (\text{B-62})$$

where  $\xi_P$  is the profile loss coefficient.



B-4. THE ENERGY PARAMETER,  $H^{***}$

In Equations (B-53) and (B-58) the denominator of the integrand is expanded using the binomial theorem, so that

$$(1 - X_E \eta^{2m})^{-1} = 1 + X_E \eta^{2m} + X_E^2 \eta^{4m} + X_E^3 \eta^{6m} + \dots \quad (\text{B-63})$$

The integral of Equation (B-58) is now written as

$$\int_0^1 \frac{\eta^{3m}}{1 - X_E \eta^{2m}} d\eta = \int_0^1 \left[ \eta^{3m} + X_E \eta^{5m} + X_E^2 \eta^{7m} + X_E^3 \eta^{9m} + X_E^4 \eta^{11m} + \dots \right] d\eta \quad (\text{B-64})$$

which, on integration becomes

$$\int_0^1 \frac{\eta^{3m}}{1 - X_E \eta^{2m}} d\eta = \frac{1}{3m+1} + \frac{X_E}{5m+1} + \frac{X_E^2}{7m+1} + \frac{X_E^3}{9m+1} + \frac{X_E^4}{11m+1} + \dots \quad (\text{B-65})$$

Therefore, Equation (B-58) becomes.

$$\frac{\delta^{***}}{\delta} = 1 - \left[ \frac{1}{3m+1} + \frac{X_E}{5m+1} + \frac{X_E^2}{7m+1} + \frac{X_E^3}{9m+1} + \frac{X_E^4}{11m+1} \right] (1 - X_E) \quad (\text{B-66})$$





which can be written as

$$\frac{\delta^{***}}{\delta} = (X_E - 1) \left[ \frac{1}{X_E - 1} + \frac{1}{3m+1} + \frac{X_E}{5m+1} + \frac{X_E^2}{7m+1} + \frac{X_E^3}{9m+1} + \frac{X_E^4}{11m+1} \right]$$

(B-67)

In a similar manner,

$$\frac{\delta^*}{\delta} = (X_E - 1) \left[ \frac{1}{X_E - 1} + \frac{1}{m+1} + \frac{X_E}{3m+1} + \frac{X_E^2}{5m+1} + \frac{X_E^3}{7m+1} + \frac{X_E^4}{9m+1} \right]$$

(B-68)

Substituting Eq. (B-67) and Eq. (B-68) into Eq. (B-61), the equation for  $H^{***}$  used in the computer program is obtained:

$$H^{***} = \frac{\frac{1}{X-1} + \frac{1}{3m+1} + \frac{X_E}{5m+1} + \frac{X_E^2}{7m+1} + \frac{X_E^3}{9m+1} + \frac{X_E^4}{11m+1}}{\frac{1}{X_E - 1} + \frac{1}{m+1} + \frac{X_E}{3m+1} + \frac{X_E^2}{5m+1} + \frac{X_E^3}{7m+1} + \frac{X_E^4}{9m+1}}$$

(B-69)



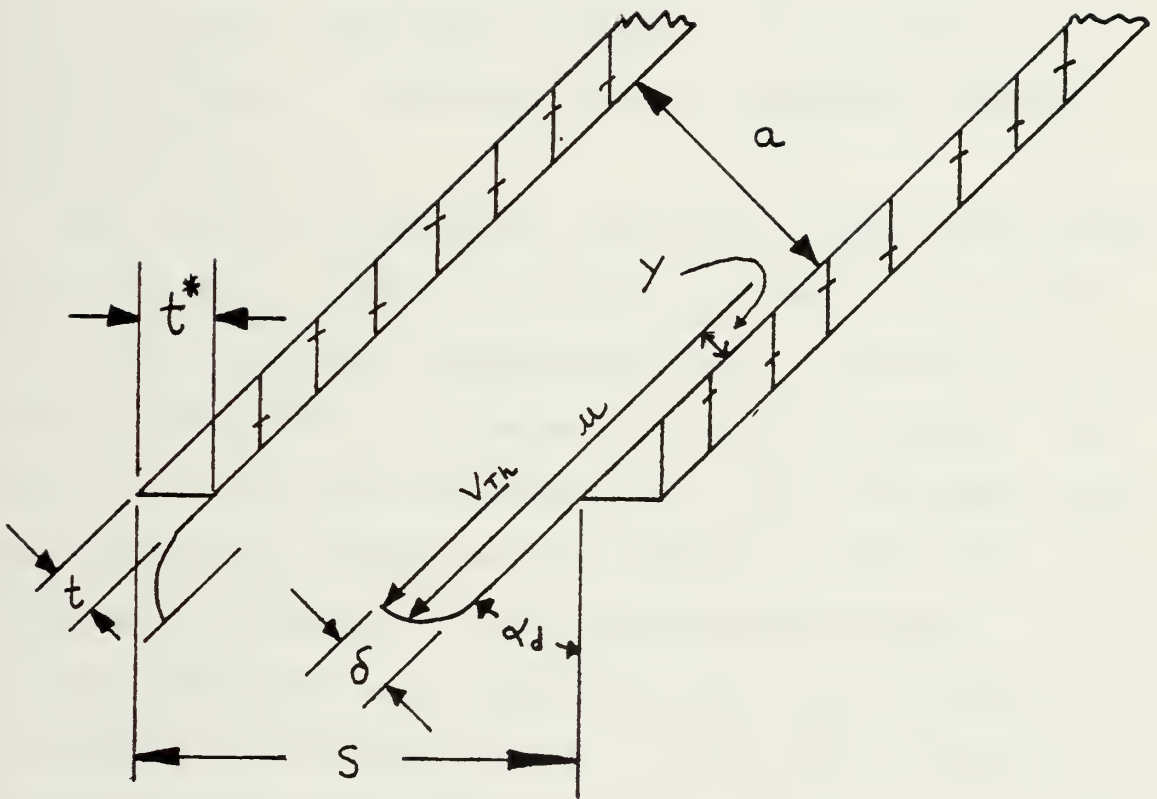

FIGURE B-1: BOUNDARY LAYER EFFECTS AT THE EXIT OF A BLADE ROW



## APPENDIX: C

### PROGRAM SEGMENTATION ON THE HP-1000

Segmentation allows large programs to be run on the HP-1000. The program is divided by the programmer into a main program and several segments, which are stored on the disc. Each segment and the main program are then compiled and loaded. When the program is executed, the main program and its segments are called into memory individually, and only as they are needed for execution. In this manner, a program can run in a partition which is smaller than that program's total size.

When the main program has performed all executable statements, the first segment is called into memory by an EXEC call. The system then loads that segment from the disc into a memory block following the end of the main program. The process is illustrated in Figure C-1. Note; the main program plus the largest segment may not together exceed 29 k. Once a segment is in memory it can call another segment.

When executing, any segment can call any subroutine which is attached to the main program. It was this feature which allowed the present program to be run. All subroutines were placed within the main program. In fact, the main program consisted of nineteen subroutines and functions. A segment may not return to the main program. Communication of data



between the main program and the segments is accomplished through a common block.

The four segments of the present program are "MAIN", "SHORT", "PART 2" and "PART 3". The manner in which control is passed from the main program to the first segment and from the first segment to the second is as follows:

BLOCK DATA

.  
. .  
. .

END

PROGRAM THESS

DIMENSION INAM (3)

DATA INAM /2HSH, 2HOR, 2HT /

.  
. .  
. .

CALL EXEC (8, INAM)

END

PROGRAM SHORT (5)

DIMENSION INAM (3)

DIMENSION NAME (3)

DATA INAM /2HSH, 2HOR, 2HT /

DATA NAME /2HPA, 2HRT, 2H2 /

.  
. .  
. .

CALL EXEC (8, NAME)





END

PROGRAM PART 2 (5)

DIMENSION NAME (3)

DIMENSION NAMR (3)

DATA NAME /2HPA, 2HRT, 2H2 /

DATA NAMR /2HPA, 2HRT, 2H3 /

.

.

.

CALL EXEC (8, NAMR)

END

PROGRAM PART 3 (5)

DIMENSION NAME (3)

DIMENSION NAMR (3)

DATA NAME /2HPA, 2HRT, 2H2 /

DATA NAMR /2HPA, 2HRT, 2H3 /

.

.

.

END

The "(5)" after the program name indicates that it is a program segment. Note the manner in which the program name is put into a data statement using the Hollerith notation.



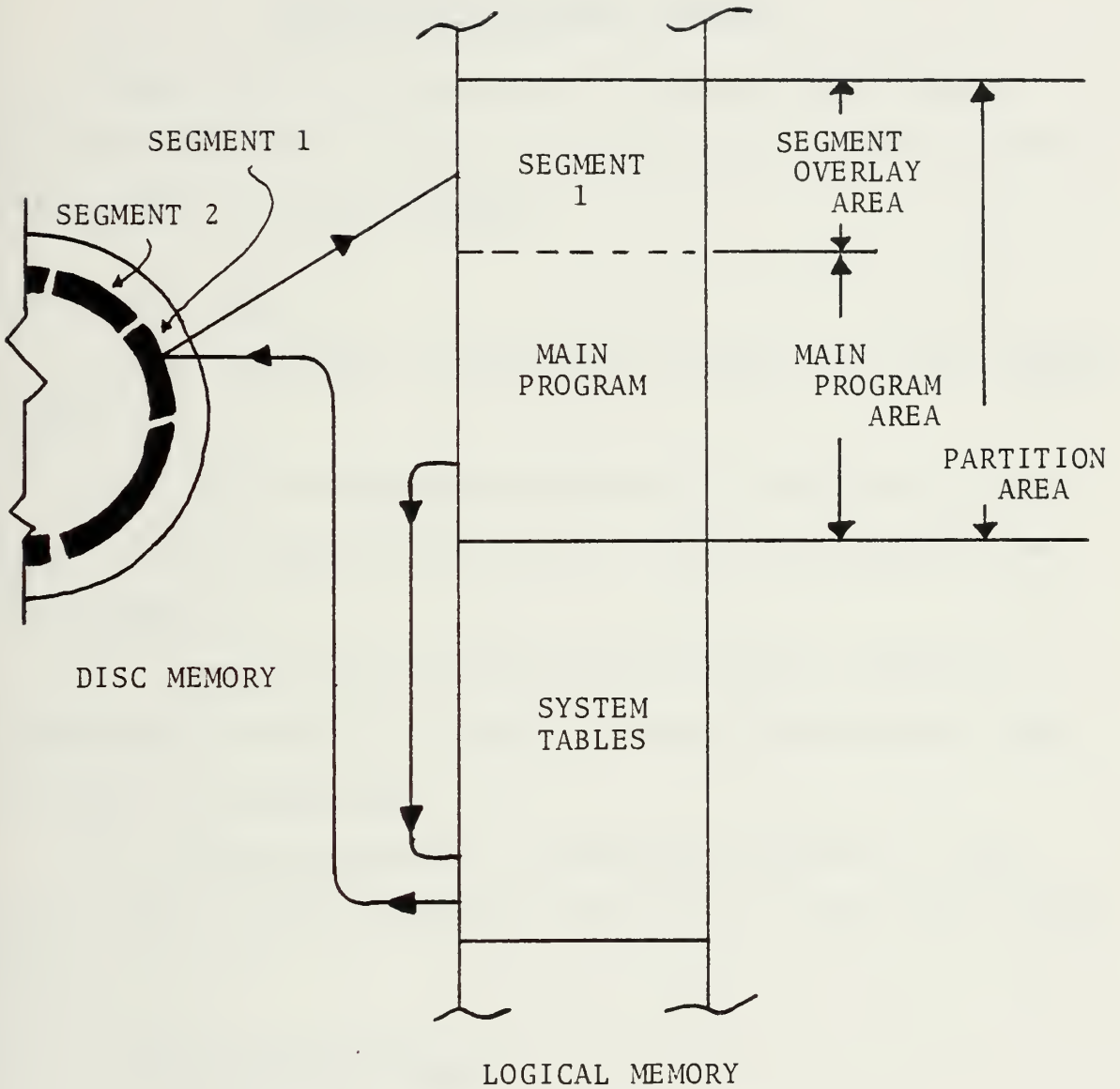

FIGURE C-1: PROGRAM SEGMENTATION-ILLUSTRATION OF THE MAIN PROGRAM CALLING A SEGMENT INTO LOGICAL MEMORY



## APPENDIX: D

### RUNNING THE COMPUTER PROGRAM

If the reader is unfamiliar with the HP-1000 Computer System, references [11] and [12] should be consulted before attempting to run the program.

#### D-1. DATA INPUT

Using the editor, input the following data into segment "SHORT".

1. Turbine operating conditions: referring to Table A-III, type in appropriate data in lines 66 through 69 and 74 through 78.

2. Special input data/program control parameters: referring to Tables A-IV and A-V, type in appropriate data in lines 83 through 98.

3. Turbine geometry: referring to Tables A-1 and A-II, type in data for stator and rotor in lines 103 through 186.

#### D-2 COMPILING THE PROGRAM

1. To compile the main program type:

```
:RU,FTN4,MAIN::25,-,-
```

2. Compile the first segment:

```
:RU,FTN4,SHORT::25,-,-
```



3. Compile the second segment:  
:RU,FTN4,PART2::25,-,-
4. Compile the final segment:  
:RU,FTN4PART3::25,-,-

### D-3. LOADING THE PROGRAM

Type

: RU, LOADR

Tap return key

Will display

LOADR:

Type

OP,LB

Will display

LOADR:

Type

:RE,%MAIN::25

Will display

LOADR:

Type

:RE,%SHORT::25

Will display

LOADR:

Type

:RE,%PART2::25

Will display





LOADR:

Type

:RE,%PART3::25

Will display

LOADR:

Type

:END

After the end statement, the loader will display that the program is ready for execution.

#### D-4 RUNNING THE PROGRAM

Type

: RUN, THESS

The program will be executed and no further action by the operator is required. The computed pressure ratio of each iteration of the outer loop of the program is displayed on the screen as it is calculated. The operator therefore has some idea where in the iteration process the computer program is executing.



## APPENDIX: E

### DISCREPANCIES IN MACCHI'S PROGRAM

1. Main program, lines 21 and 22; the value of ICL has not yet been read.
2. Main program, lines 163-166; the Traupel method of calculating gas outlet angles does not take the Mach number into consideration. However, in lines 163-164, the program is attempting to draw a parabola through points which represent outlet angle as a function of Mach number.
3. Main program line 281; the calling of subroutine SLINE is questionable. Parameters are transferred to that subroutine, but many of them have not yet been defined (HE, DHEDX, WPER2, DSDX1). These undefined variables will be set equal to zero by the IBM 360 and 370 computers. Thus, in line 10 of subroutine SLINE, the value of DWDX will be zero and in line 17, division by zero will occur and the execution of the program should cease.
4. Subroutine ROTORI lines 22 and 26; the stator radii are used in the calculation whereas the rotor radii should be used.
5. Subroutine ASOSI, line 107; the correct Fortran code is
$$\text{ZETAPS(I)} = .5 * \text{ZETAS(I)}$$



6. Subroutine ALOS2, line 121; the correct Fortran code is

$$\text{ZETAPR}(I) = .5 * \text{ZETAPR}(I)$$

7. Subroutine ALOS2, lines 123-126; the stator radii are used in the calculation whereas the rotor radii should be used.

8. Subroutine ANGAIN, line 14; the correct Fortran code is

$$\begin{aligned} \text{AO} = & \text{ATAN}(1. - \text{XCL}/\text{H} * \text{CH} * \text{COS}(\text{ANG1}) / \text{COS}(\text{ANG2}) * \\ & \text{TAN}(\text{ANG2}) + \text{XCL}/\text{H} * \text{CL} * \text{COS}(\text{ANG1}) / \text{COS}(\text{ANG2}) * \\ & \text{TAN}(\text{ANG1}) \end{aligned}$$

Note: Since reference [2] was published, Professor Macchi's program has been further developed by Professor Macchi under private sponsorship [Ref. 13]. The new code however, is not generally available.



APPENDIX F  
COMPUTER OUTPUT





INPUT PRINTS

R1	A1	R2	AP
2.764	2126	2.693	1912
2.860	2215	2.820	2030
2.956	2303	2.947	2149
3.052	2393	3.074	2269
3.140	2481	3.201	2388
3.243	2570	3.329	2506
3.339	2660	3.456	2625
3.445	2749	3.583	2745
3.531	2837	3.710	2864
3.627	2926	3.837	2983

NUMBER OF STATOR BLADES = 31  
 NUMBER OF ROTOR BLADES = 37  
 ROTOR TIP CLEARANCE = .0100  
 AXIAL DISTANCE = 1.88  
 CURVATURE FACTOR K = 5.00

BLADING GEOMETRY

	C	E	T	TE	IN	AL	R
STATOR	1.0030	2.8065	.2252	.0300	.0186	1.0880	2.7640
	1.0030	2.8065	.2252	.0300	.0186	1.0880	3.1255
	1.0030	2.8065	.2252	.0300	.0186	1.0880	3.6270
ROTOR	1.0030	2.4500	.2252	.0300	.0186	1.0880	2.6930
	1.0030	2.4500	.2252	.0300	.0186	1.0880	3.2650
	1.0030	2.4500	.2252	.0300	.0186	1.0880	3.8370

ALL DIMENSIONS INDICATED IN THIS TABLE ARE IN INCHES

CORRELATION SYSTEM  
 ICOR = 4  
 ICAN = 2  
 ICANZ = 6  
 ICANC = 1  
 ICCL = 0  
 ICORN = 3

GAS PROPERTIES (BTU/LB F) .240 MOLECULAR MASS 28.970 GAMM 1.400  
 VISCOSITY (1) (LBM /SEC FT) .130E-04  
 VISCOSITY (2) (LBM /SEC FT) .120E-04



SET CASE RPM TOTAL/STATIC INLET TOTAL INLET TOTAL  
 NUMBER NUMBER 5000.0 PRESSURE RATIO PRESSURE TEMPERATURE TEMPERATURE  
 1 1 1.400 20.580 545.50

STATOR EXIT SOLUTION

STREAM LINE	RADIAL POSITION (IN)	X=R/RM	RADIAL SHIFT (IN)	BLADE OPENING (IN)	Y=VA /VAN	BLADE EFFICIENCY	LOSS COEFFICIENT	CONTINUITY	ZETA*	FLOW RATE FRACTION
1	2.754	.865	0.0000	.2126	1.1015	.8980	.1020	.1020	.1020	0.0000
2	3.003	.940	0.0000	.2347	1.0468	.8935	.1065	.1065	.1065	.2581
3	3.175	1.000	0.0000	.2526	1.0000	.8999	.1101	.1101	.1101	.4790
4	3.432	1.074	0.0000	.2745	.9407	.8071	.1129	.1129	.1129	.7609
5	3.627	1.135	0.0000	.2926	.8916	.8847	.1153	.1153	.1153	1.0000

ABSOLUTE VELOCITY (FPS)

STREAM LINE	AXIAL COMPONENT	RADIAL COMPONENT	TANGENTIAL COMPONENT	OVERALL VELOCITY	AXIAL COMPONENT	RADIAL COMPONENT	TANGENTIAL COMPONENT	OVERALL VELOCITY	WHEEL VELOCITY
1	332.90	-13.35	735.38	807.33	332.90	-13.35	614.78	699.25	120.60
2	316.36	3.01	691.09	760.06	316.36	3.01	560.05	643.23	131.03
3	295.48	6.91	654.34	720.80	295.48	6.91	514.91	593.71	139.43
4	284.29	24.69	610.59	673.98	284.29	24.69	460.86	542.05	149.73
5	269.47	31.97	574.92	635.75	269.47	31.97	416.67	497.24	158.28

MACH NUMBER FLOW ANGLE (DEG. R)

STREAM LINE	ABSOLUTE	RELATIVE	ABSOLUTE	RELATIVE	TOTAL	STATIC	TOTAL	STATIC	101/TOT	101/STA
1	.74	.64	65.65	61.57	545.50	491.26	19.691	13.648	1.0452	1.5074
2	.70	.59	65.41	60.54	545.50	497.43	19.762	14.309	1.0414	1.4382
3	.66	.54	65.21	60.16	545.50	502.27	19.833	14.848	1.0383	1.3891
4	.61	.49	65.04	58.33	545.50	507.70	19.905	15.482	1.0349	1.3424
5	.57	.45	64.89	57.11	545.50	511.07	19.970	15.983	1.0305	1.2876



SET NUMBER PAGE NUMBER RPM TOTAL/STATIC PRESSURE RATIO INLET TOTAL TEMPERATURE (DEG. R) INLET STATIC TEMPERATURE (DEG. R)

1 2 5000.0 1.400 20.580 545.50

ROTOR EXIT SOLUTION

STREAM LINE	RADIAL POSITION	X=R/RM	RADIAL SHIFT	BLADE OPENING	BLADE EFFICIENCY	Y=VA/UM	LOSS COEFFICIENT	ZETA*	CONTINUITY	FLOW RATE FRACTION
1	3.693	.825	-.0710	.1912	.7689	.9734	.2311	.2311	0.0000	
2	3.020	.925	-.0169	.2249	.7684	.8964	.2320	.2320	.2418	
3	3.269	1.000	-.0455	.2747	.7674	1.0000	.2326	.2326	.4446	
4	3.595	1.098	-.1537	.2947	.7711	1.0392	.2289	.2289	.7358	
5	3.837	1.175	-.2100	.2963	.7740	1.0911	.2260	.2260	1.0000	

ABSOLUTE VELOCITY (FPS) RELATIVE VELOCITY (FPS)

STREAM LINE	AXIAL COMPONENT	RADIAL COMPONENT	TANGENTIAL COMPONENT	OVERALL VELOCITY	AXIAL COMPONENT	RADIAL COMPONENT	TANGENTIAL COMPONENT	OVERALL VELOCITY	WHEEL VELOCITY
1	214.02	-8.62	-397.46	453.64	214.82	-8.62	-516.96	559.89	117.50
2	217.09	5.07	-373.35	443.29	219.89	2.09	-505.11	550.90	131.77
3	220.62	16.05	-347.58	431.76	220.69	5.05	-490.05	537.47	143.46
4	223.78	28.72	-323.13	396.76	229.35	19.93	-479.57	531.96	156.44
5	240.79	38.57	-313.63	396.43	240.79	28.57	-441.05	538.71	167.42

MACH NUMBER FLOW ANGLE (DEG)

STREAM LINE	ABSOLUTE	RELATIVE	TEMPERATURE (DEG. R)	STATIC	TOTAL	10T/10T	10T/STA
1	.41	-61.73	522.93	505.80	16.080	14.311	1.4383
2	.39	-59.51	522.24	506.62	16.090	14.467	1.4225
3	.37	-57.59	522.08	507.63	16.162	14.650	1.4043
4	.36	-54.64	521.87	508.77	16.242	14.859	1.3853
5	.36	-52.49	521.62	509.54	16.260	14.877	1.3657

EQUIVALENT INLET PRESSURE (PSI) EQUIVALENT INLET TEMPERATURE (DEG. R)

STREAM LINE	EQUIVALENT INLET PRESSURE (PSI)	EQUIVALENT INLET TEMPERATURE (DEG. R)
1	18.074	1.3
2	18.088	1.3
3	18.119	1.2
4	18.272	1.2
5	18.376	1.2



SET NUMBER	PACE NUMBER	RPM	TOTAL/STATIC PRESSURE RATIO	INLET TOTAL PRESSURE (PSI)	INLET TOTAL TEMPERATURE (DEG. R)
1	3	5000.0	1.400	20.580	545.50

OVERALL TURBINE CHARACTERISTICS

STREAM LINE	PRESSURE RATIO TOT/STA	EFFICIENCY TOT/10T	HEAD COEFFICIENT	BLADE/JET SPEED RATIO	THEORETICAL DEGREE OF REACTION
1	1.4384	.6279	44.4145	1500	-.1231
2	1.4225	.6279	34.5720	1754	-.0595
3	1.4048	.6416	31.2045	1790	.0375
4	1.3950	.6433	25.9802	1942	.1209
5	1.3833	.6724	23.1752	2077	.2130

MASS AVERAGED QUANTITIES

HORSE POWER =	20.27 (HP)
MOMENT FLOW RATE =	21.29 (FT-LB) (LB/SEC)
REFERRED RPM =	4874.22 (HP)
REFERRED HORSE POWER =	14.12 (HP)
REFERRED MOMENT FLOW RATE =	15.21 (FT-LB) (LB/SEC)

TOTAL/STATIC EFFICIENCY =	.4634
TOTAL/STATIC PRESSURE RATIO =	1.4058
TOTAL/STATIC PRESSURE RATIO =	1.2231

HEAD COEFFICIENT	31.8904
BLADE/JET SPEED RATIO	1.771
THEORETICAL DEGREE OF REACTION	.0435
MACH NUMBER AT STATION 0	1.856





SET PAGE RPM TOTAL/STATIC INLET TOTAL INLET TOTAL  
 NUMBER NUMBER 10000.0 PRESSURE RATIO PRESSURE TEMPERATURE  
 1 1.400 20,580 545.50 545.50

STATOR EXIT SOLUTION

STREAM LINE	RADIAL POSITION (IN)	X=R/RH	RADIAL SHIFT (IN)	BLADE OPENING (IN)	Y=VA /VAM	EFFICIENCY	BLADE EFFICIENCY	LOSS COEFFICIENT	ZCIA* CONTINUITY	FLOW RATE FRACTION
1	2.764	.865	0.0000	.2126	1.0991	.8889	.8889	.1111	.1111	0.0000
2	3.003	.940	0.0000	.2347	1.0455	.8856	.8856	.1144	.1144	.2602
3	3.195	1.000	0.0000	.2526	1.0000	.8829	.8829	.1171	.1171	.4813
4	3.432	1.074	0.0000	.2745	1.9430	.8852	.8852	.1148	.1148	.7624
5	3.627	1.135	0.0000	.2926	.8960	.8872	.8872	.1128	.1128	1.0000

ABSOLUTE VELOCITY (FPS)

RELATIVE VELOCITY (FPS)

STREAM LINE	AXIAL COMPONENT	RADIAL COMPONENT	TANGENTIAL COMPONENT	OVERALL VELOCITY	AXIAL COMPONENT	RADIAL COMPONENT	TANGENTIAL COMPONENT	OVERALL VELOCITY	WUFL VELOCITY
1	291.65	-11.70	644.22	707.30	291.65	-11.70	403.06	497.65	241.21
2	277.43	2.64	606.06	666.55	277.43	2.64	343.99	441.93	243.07
3	265.76	6.07	574.53	632.89	265.76	6.07	295.67	397.34	256.86
4	250.25	21.73	537.47	593.27	250.25	21.73	238.00	366.03	279.47
5	237.78	28.21	507.31	560.98	237.78	28.21	190.79	306.16	316.52

MACH NUMBER

FLOW ANGLE (DEG, R)

TEMPERATURE (DEG, R)

PRESSURE (PSI)

STREAM LINE	ABSOLUTE	RELATIVE	ABSOLUTE	RELATIVE	TOTAL	STATIC	TOTAL	STATIC	TOT/TOI	TOT/STIA
1	.64	.45	65.65	54.12	545.50	503.87	19.846	15.032	1.0370	1.3691
2	.60	.46	62.21	50.12	545.50	508.53	19.846	15.032	1.0336	1.3214
3	.57	.46	62.21	48.10	545.50	512.17	19.846	15.032	1.0308	1.2853
4	.53	.47	65.04	43.57	545.50	516.21	20.122	16.533	1.0262	1.2448
5	.50	.27	64.89	38.75	545.50	519.31	20.122	16.533	1.0228	1.2149



SET NUMBER PAGE NUMBER RPM  
 1 2 10000.0  
 INLET TOTAL PRESSURE (PSI) 20.580  
 INLET TOTAL TEMPERATURE (DEG. R) 545.50  
 ISIAL/STATIC PRESSURE RATIO 1.400

KOTOR EXIT SOLUTION

STREAM LINE	RADIAL POSITION	X=R/RM	SHIFT	RADIAL OPENING	BLADE ANGLE	Y=VA/VAM	EFFICIENCY	LOSS COEFFICIENT	CONTINUTY	FRACTION RATE
1	2.623	.825	.0710	.1912	.837	.9837	.8289	.1715	.1715	0.0000
2	3.020	.925	-.0168	.2218	.9556	.9556	.8373	.1628	.1628	.2340
3	3.265	1.000	-.0405	.2447	1.0000	1.0000	.8438	.1563	.1563	.4308
4	3.585	1.098	-.1537	.2747	1.0916	1.0916	.8515	.1485	.1485	.7242
5	3.837	1.175	-.2100	.2983	1.1871	1.1871	.8576	.1425	.1425	1.0000

ABSOLUTE VELOCITY (FPS)

RELATIVE VELOCITY (FPS)

STREAM LINE	AXIAL COMPONENT	RADIAL COMPONENT	TANGENTIAL COMPONENT	OVERALL VELOCITY	AXIAL COMPONENT	RADIAL COMPONENT	TANGENTIAL COMPONENT	OVERALL VELOCITY	WHIFT VELOCITY
1	201.32	-R.08	-249.46	320.66	201.32	-R.08	-484.47	524.70	235.04
2	195.57	1.86	-185.71	269.70	195.57	1.86	-449.25	489.97	243.54
3	204.66	4.68	-169.51	265.78	204.66	4.68	-454.44	498.42	240.83
4	223.41	19.40	-154.28	272.20	223.41	19.40	-457.17	518.36	242.88
5	242.95	28.82	-150.52	287.25	242.95	28.82	-485.36	543.54	334.84

MACH NUMBER

FLOW ANGLE (DEG)

TEMPERATURE (DEG. R)

PRESSURE RATIO

STREAM LINE	ABSOLUTE	RELATIVE	ABSOLUTE	RELATIVE	TOTAL	STATIC	TOTAL	STATIC	101/101	101/STA
1	.29	.48	-51.10	-67.44	509.88	504.32	15.156	14.284	1.3572	1.4407
2	.24	.44	-43.59	-66.48	510.82	504.87	15.441	14.701	1.3525	1.3923
3	.25	.45	-39.64	-65.76	510.88	504.92	15.445	14.832	1.3525	1.3876
4	.25	.47	-34.61	-64.45	510.98	504.52	15.484	14.859	1.3582	1.3859
5	.26	.49	-31.98	-63.41	510.99	503.52	15.494	14.777	1.3583	1.3927

STREAM LINE	EQUIVALENT TEMPERATURE (DEG. R)	EQUIVALENT INLET PRESSURE (PSI)	EQUIV/STATIC PRESSURE RATIO
1	524.23	17.262	1.2
2	524.85	17.306	1.2
3	525.59	17.329	1.2
4	526.86	17.627	1.2
5	528.11	17.984	1.2



SET NUMBER	PAGE NUMBER	RPM	TOTAL/STATIC PRESSURE RATIO	INLET TOTAL PRESSURE (PSI)	INLET TOTAL TEMPERATURE (DEG. R)
1	3	10000.0	1.400	20.580	545.50

OVERALL TURBINE CHARACTERISTICS

STREAM LINE	PRESSURE RATIO TOT/STA	EFFICIENCY TOT/TOT	HEAD COEFFICIENT	BLADE/JET SPEED RATIO	THEORETICAL DEGREE OF REACTION
1	1.4007	.6591	11.1627	.2993	.1334
2	1.3623	.7491	8.6122	.3408	.1518
3	1.3626	.8080	7.5311	.3644	.2253
4	1.3859	.8195	6.5026	.3920	.3107
5	1.4927	.8263	5.7090	.4114	.4008

MASS AVERAGED QUANTITIES

HORSE POWER =	28.96 (HP)
MOMENT =	15.21 (FT-LB)
FLOW RATE =	2.45 (LB/SEC)

REFERRED RPM =	9748.44
REFERRED HORSE POWER =	20.17 (HP)
REFERRED MOMENT =	10.86 (FT-LB)
REFERRED FLOW RATE =	1.79 (LB/SEC)

TOTAL/STATIC EFFICIENCY =	.7044
TOTAL/TOTAL EFFICIENCY =	.8075
TOTAL/STATIC PRESSURE RATIO =	1.3956
TOTAL/TOTAL PRESSURE RATIO =	1.3348

HEAD COEFFICIENT =	7.7267
BLADE/JET SPEED RATIO =	.3581
THEORETICAL DEGREE OF REACTION =	.2407
MACH NUMBER AT STATION 0 =	.1777



SET NUMBER 1 PAGE 1 RPM 15000.0 TOTAL/STATIC PRESSURE RATIO 1.400 INLET TOTAL PRESSURE 20.580 INLET TOTAL TEMPERATURE 545.50

STATOR EXIT SOLUTION

STREAM LINE	RADIAL POSITION (IN)	X=R/RM	RADIAL SHIFT (IN)	BLADE OPENING (IN)	BLADE EFFICIENCY	Y=VA /VAM	LOSS COEFFICIENT	ZETA* CONTORTIVITY	FLOW RATE FRACTION
1	2.764	.865	0.0000	.2126	.8955	1.0777	.1045	.1045	0.0000
2	3.093	.740	0.0000	.2147	.8953	1.0453	.1047	.1047	.2610
3	3.132	1.000	0.0270	.2526	.8952	1.0000	.1048	.1048	.4826
4	3.452	1.074	0.0000	.2745	.8948	.9416	.1052	.1052	.7635
5	3.627	1.135	0.0000	.2926	.8945	.8928	.1055	.1055	1.0000

STREAM LINE	ABSOLUTE VELOCITY (FPS)			RELATIVE VELOCITY (FPS)			WHEEL VELOCITY
	RADIAL COMPONENT	AXIAL COMPONENT	OVERALL VELOCITY	RADIAL COMPONENT	TANGENTIAL COMPONENT	OVERALL VELOCITY	
1	-11.22	618.08	678.55	-11.22	256.27	379.59	361.81
2	2.53	582.07	640.16	2.53	108.97	326.67	393.10
3	5.83	551.88	607.93	5.83	133.59	287.84	418.29
4	20.84	515.46	568.98	20.84	66.26	249.85	449.20
5	27.00	485.56	536.93	27.00	10.79	229.43	474.77

STREAM LINE	MACH NUMBER			TEMPERATURE (DEG. R)			PRESSURE RATIO	
	ABSOLUTE	RELATIVE	TOTAL	ABSOLUTE	RELATIVE	TOTAL	STATIC	TOTAL
1	.61	.34	65.65	42.49	507.19	19.952	15.463	1.0415
2	.58	.29	65.41	35.35	511.40	20.024	15.923	1.0228
3	.55	.26	65.21	27.66	514.75	20.081	16.390	1.0228
4	.51	.22	65.04	15.93	518.56	20.144	16.822	1.0217
5	.48	.20	64.89	8.71	521.51	20.192	17.251	1.0192





SET PAGE RPM TOTAL/STATIC INLET TOTAL INLET TOTAL  
 NUMBER NUMBER PRESSURE RATIO PRESSURE PRESSURE TEMPERATURE TEMPERATURE  
 (PSI) (DEC. R)

1 2 15000.0 1.400 20.580 545.50

ROTOR EXIT SOLUTION

STREAM LINE	RADIAL POSITION	X=R/RM	SHIFT	RADIAL OPENING	BLADE	Y=VA /VAM	EFFICIENCY	LOSS COEFFICIENT	CONTINUITY	7E10*	FLOW RATE FRACTION
1	2.693	.825	.0710	.1912	.8722	.9944	.8722	.1279	.1279	.1279	0.0000
2	3.020	.825	-.0168	.2218	.8785	.9132	.8785	.1216	.1216	.1216	.2253
3	3.265	1.000	-.0405	.2447	.8832	1.0000	.8832	.1169	.1169	.1169	.4152
4	3.585	1.098	-.1537	.2747	.8737	1.1537	.8737	.1263	.1263	.1263	.7112
5	3.837	1.175	-.2100	.2983	.8663	1.3031	.8663	.1337	.1337	.1337	1.0000

ABSOLUTE VELOCITY (FPS)

RELATIVE VELOCITY (FPS)

STREAM LINE	AXIAL COMPONENT	RADIAL COMPONENT	TANGENTIAL COMPONENT	OVERALL VELOCITY	AXIAL COMPONENT	RADIAL COMPONENT	TANGENTIAL COMPONENT	OVERALL VELOCITY	OVERALL VELOCITY	WHIRL VELOCITY
1	192.13	-7.71	-109.84	221.44	192.13	-7.71	-462.35	500.74	500.74	352.51
2	176.44	1.68	-10.00	176.44	176.44	1.68	-429.30	442.05	442.05	395.31
3	193.21	4.42	-1.64	193.21	193.21	4.42	-429.03	470.55	470.55	427.19
4	232.92	19.36	3.20	233.78	222.95	19.36	-466.13	512.05	512.05	429.33
5	251.77	29.87	-.72	253.54	251.77	29.87	-502.98	563.27	563.27	502.26

MACH NUMBER

FLOW ANGLE (DEG)

TEMPERATURE (DEC. R)

PRESSURE (PSI)

PRESSURE RATIO

STREAM LINE	ABSOLUTE	RELATIVE	ABSOLUTE	RELATIVE	TOTAL	STATIC	TOTAL	STATIC	TOT/TOT	TOT/STA
1	.20	.46	-29.76	-67.44	501.84	497.76	14.582	14.171	1.4113	1.4523
2	.16	.40	-33.24	-66.48	506.74	503.86	15.277	14.961	1.3210	1.3756
3	.18	.43	-49.82	-65.76	506.97	503.86	15.277	14.961	1.3210	1.3756
4	.20	.47	-.82	-64.45	507.21	503.02	15.268	14.833	1.3271	1.3784
5	.23	.51	-1.16	-63.41	507.07	501.72	15.197	14.633	1.3279	1.3874

STREAM LINE	EQUIVALENT TEMPERATURE (DEC. R)	EQUIVALENT INLET PRESSURE (PSI)	EQUIV/STATIC PRESSURE RATIO
1	518.62	16.718	1.2
2	520.42	17.083	1.1
3	522.28	17.245	1.2
4	525.28	17.451	1.2
5	528.13	18.029	1.2



SET NUMBER	PAGE NUMBER	RPM	TOTAL/STATIC PRESSURE RATIO	INLET TOTAL PRESSURE (PSI)	INLET TOTAL TEMPERATURE (DEG. R)
1	3	15000.0	1.400	20.580	545.50

OVERALL TURBINE CHARACTERISTICS

STREAM LINE	PRESSURE RATIO TOT/STA	EFFICIENCY TOT/10T	HEAD COEFFICIENT	BLADE/JET SPEED RATIO	THEORETICAL DEGREE OF REACTION
1	1.4523	.8538	5.0637	.444	.2243
2	1.3756	.8632	3.6937	.5203	.1981
3	1.3471	.8657	3.5684	.5531	.2781
4	1.3874	.8584	2.9014	.5871	.3821
5	1.4054	.8488	2.6748	.6092	.4694

MASS AVERAGED QUANTITIES

HORSE POWER = 31.71 (HP)  
 MOMENT = 13.10 (FT-LB)  
 FLOW RATE = 2.39 (LB/SEC)

REFERRED RPM = 14622.66 (HP)  
 REFERRED HORSE POWER = 22.08 (HP)  
 REFERRED MOMENT = 7.93 (FT-LB)  
 REFERRED FLOW RATE = 1.75 (LB/SEC)

TOTAL/STATIC EFFICIENCY = .7968  
 TOTAL/TOTAL EFFICIENCY = .8594  
 TOTAL/STATIC PRESSURE RATIO = 1.3521  
 TOTAL/TOTAL PRESSURE RATIO = 1.3522

HEAD COEFFICIENT = 3.4357  
 BLADE/JET SPEED RATIO = .5395  
 THEORETICAL DEGREE OF REACTION = .3013  
 MACH NUMBER AT STATION 0 = 1.735



SET NUMBER 1  
 PAGE NUMBER 1  
 RPM 20000.0  
 TOTAL/STATIC PRESSURE RATIO 1.400  
 INLET TOTAL PRESSURE 20.580  
 INLET TOTAL TEMPERATURE 545.50

STATOR EXIT SOLUTION

STREAM LINE	RADIAL POSITION (IN)	X=R/RM	RADIAL SHIFT (IN)	BLADE OPENING (IN)	Y=VA /VAM	BLADE EFFICIENCY	LOSS COEFFICIENT	ZETA* CONTINUITY	FLOW RATE FRACTION
1	2.764	.865	0.0000	.2126	1.1027	.9123	.0877	.0877	0.0000
2	3.003	.940	0.0000	.2347	1.0473	.9091	.0909	.0909	.2613
3	3.135	1.000	.0290	.2526	1.0000	.9065	.0935	.0935	.4829
4	3.432	1.074	0.0000	.2745	.8903	.9051	.0949	.0949	.7637
5	3.627	1.135	0.0000	.2926		.9040	.0960	.0960	1.0000

ABSOLUTE VELOCITY (FPS)

RELATIVE VELOCITY (FPS)

STREAM LINE	AXIAL COMPONENT	RADIAL COMPONENT	TANGENTIAL COMPONENT	OVERALL VELOCITY	AXIAL COMPONENT	RADIAL COMPONENT	TANGENTIAL COMPONENT	OVERALL VELOCITY	WHEEL VELOCITY
1	291.10	-11.68	643.06	705.98	291.10	-11.68	160.65	332.69	482.41
2	276.49	2.63	604.00	664.29	276.49	2.63	79.86	287.81	524.14
3	241.95	6.04	571.59	629.64	241.95	6.04	13.87	242.42	557.22
4	248.16	21.55	532.98	588.31	248.16	21.55	-65.96	257.68	594.94
5	235.05	27.89	501.49	554.54	235.05	27.89	-131.54	270.79	633.03

MACH NUMBER

TEMPERATURE (DEG. R)

PRESSURE RATIO

STREAM LINE	ABSOLUTE	RELATIVE	ABSOLUTE	RELATIVE	TOTAL	STATIC	TOTAL	STATIC	TOI/10T	TOI/5TA
1	.64	.30	65.65	28.89	545.50	504.03	20.016	15.177	1.0282	1.4540
2	.60	.26	65.41	16.11	545.50	508.20	20.055	15.722	1.0324	1.4024
3	.57	.22	65.21	3.20	545.50	512.51	20.102	16.163	1.0337	1.3573
4	.53	.23	65.04	-14.89	545.50	516.70	20.162	16.676	1.0307	1.3041
5	.50	.24	64.89	-29.24	545.50	519.91	20.206	17.079	1.0185	1.2050



SET NUMBER PAGE RPM IONIAL/STATIC PRESSURE INLET TOTAL TEMPERATURE TOTAL TEMPERATURE (DEG. R)

1 2 20000.0 1.400 20.580 545.50

KOTOR EXIT SOLUTION

STREAM LINE	RADIAL POSITION	X=R/RM	RADIAL SHIFT	BLADE OPENING	FLADE	Y=VA /VAM	EFFICIENCY	LOSS COEFFICIENT	CONTINUITY	VELOCITY	FLOW RATE
1	3.693	.825	.0710	.1912	.1912	1.0076	.8915	.1095	.1085	0.0000	
2	3.020	.975	-.0168	.2218	.2218	.8705	.8756	.1244	.1244	.2140	
3	3.265	1.000	-.0405	.2447	.2447	1.0000	.8637	.1364	.1364	.3939	
4	3.585	1.098	-.1537	.2747	.2747	1.2350	.8696	.1304	.1304	.6917	
5	3.837	1.175	-.2100	.2983	.2983	1.4565	.8743	.1258	.1258	1.0000	

ABSOLUTE VELOCITY (FPS)

RELATIVE VELOCITY (FPS)

STREAM LINE	AXIAL COMPONENT	RADIAL COMPONENT	TANGENTIAL COMPONENT	OVERALL VELOCITY	AXIAL COMPONENT	RADIAL COMPONENT	TANGENTIAL COMPONENT	OVERALL VELOCITY	WHEEL VELOCITY
1	178.28	-7.15	40.98	183.07	178.28	-7.15	40.98	183.07	470.02
2	154.03	1.46	173.25	231.62	154.03	1.46	173.25	231.62	527.07
3	176.94	4.05	176.95	250.27	176.94	4.05	176.95	250.27	569.85
4	218.53	18.98	168.82	276.29	218.53	18.98	168.82	276.29	625.97
5	257.72	30.58	154.81	302.20	257.72	30.58	154.81	302.20	669.68

MACH NUMBER

FLOW ANGLE (DEG)

TEMPERATURE (DEG. R)

PRESSURE RATIO

STREAM LINE	ABSOLUTE	RELATIVE	ABSOLUTE	RELATIVE	TOTAL	STATIC	TOTAL	STATIC	TOT/TOT	TOT/STA
1	.17	.43	12.95	-67.44	497.08	494.29	14.234	13.957	1.4458	1.4745
2	.21	.35	48.36	-66.48	508.01	503.54	15.448	14.978	1.3322	1.3741
3	.23	.39	45.00	-65.76	509.23	503.58	15.536	14.890	1.3247	1.3621
4	.25	.46	37.69	-64.45	509.94	503.58	15.574	14.903	1.3214	1.3609
5	.28	.52	30.99	-63.41	509.92	502.32	15.519	14.725	1.3241	1.3777

EQUIVALENT EQUIV/STATIC PRESSURE RATIO

EQUIV/STATIC PRESSURE RATIO

EQUIV/STATIC PRESSURE RATIO

STREAM LINE

1	512.26	16.062	1.2
2	515.93	16.509	1.1
3	518.54	16.837	1.1
4	524.94	17.628	1.2
5	529.99	18.265	1.2





SET NUMBER	PAGE NUMBER	RPM	TOTAL/STATIC PRESSURE RATIO	INLET TOTAL PRESSURE (PSI)	INLET TOTAL TEMPERATURE (DEG. R)
1	3	20000.0	1.400	20.580	545.50

OVERALL TURBINE CHARACTERISTICS

STREAM LINE	PRESSURE RATIO TOT/STA	EFFICIENCY TOT/TOT	HEAD COEFFICIENT TOT/TOT	SLIDE RATIO	THEORETICAL DEGREE OF REACTION
1	1.4745	.8451	2.9583	.5814	.2065
2	1.3741	.7919	2.0709	.7349	.1468
3	1.3621	.7529	1.8612	.7310	.5448
4	1.3809	.8814	1.6090	.7882	.3378
5	1.3977	.8419	1.4923	.8186	.4311

MASS AVERAGED QUANTITIES

HORSE POWER =	28.63 (HP)
MOMENT =	7.52 (FT-LB)
FLOW RATE =	2.25 (LR/SEC)
REFERRED RPM =	19496.88
REFERRED HORSE POWER =	19.94 (HP)
REFERRED MOMENT =	5.37 (FT-LB)
REFERRED FLOW RATE =	1.65 (LR/SEC)

TOTAL/STATIC EFFICIENCY =	.7662
TOTAL/TOTAL EFFICIENCY =	.8628
TOTAL/STATIC PRESSURE RATIO =	1.3933
TOTAL/TOTAL PRESSURE RATIO =	1.3411

HEAD COEFFICIENT =	1.9418
SLIDE RATIO =	.7176
THEORETICAL DEGREE OF REACTION =	.2620
MACH NUMBER AT STATION 0 =	.1629



SET NUMBER 1  
 PACE NUMBER 1  
 RPM 25000.0  
 TOTAL/STATIC PRESSURE RATIO 1.400  
 INLET TOTAL PRESSURE 20.580  
 INLET TOTAL TEMPERATURE 545.50

STATOR EXIT SOLUTION

STREAM LINE	RADIAL POSITION (IN)	X=R/RM	RADIAL SHIFT (IN)	BLADE OPENING (IN)	Y=VA /VAM	BLADE EFFICIENCY	LOSS COEFFICIENT	ZETA* CONTINUITY	FLOW RATE FRACTION
1	2.764	.865	0.0000	.2126	1.1005	.9145	.0955	.0955	0.0000
2	3.063	.940	0.0000	.2347	1.0465	.9026	.0974	.0974	.2612
3	3.195	1.000	0.2900	.2526	1.0000	.9011	.0989	.0989	.4827
4	3.432	1.074	0.0000	.2745	.8997	.8997	.1003	.1003	.7637
5	3.627	1.135	0.0000	.2926	.8912	.8986	.1014	.1014	1.0000

RELATIVE VELOCITY (FPS)

STREAM LINE	AXIAL COMPONENT	RADIAL COMPONENT	TANGENTIAL COMPONENT	OVERALL VELOCITY	AXIAL COMPONENT	RADIAL COMPONENT	TANGENTIAL COMPONENT	OVERALL VELOCITY	WHEEL VELOCITY
1	285.88	-11.47	631.53	693.32	285.88	-11.47	28.52	287.53	603.01
2	271.85	2.58	593.87	653.14	271.85	2.58	-61.31	278.69	655.17
3	263.01	5.94	562.45	619.58	263.01	5.94	-134.70	295.56	697.15
4	244.34	21.22	524.77	579.25	244.34	21.22	-233.90	312.09	748.67
5	231.51	27.47	493.94	546.20	231.51	27.47	-297.35	377.85	791.29

FLOW ANGLE (DEG)

STREAM LINE	ABSOLUTE RELATIVE	ABSOLUTE RELATIVE	RELATIVE	TEMPERATURE (DEG. R)	TEMPERATURE (DEG. R)	PRESSURE (PSI)	PRESSURE RATIO
1	.63	.26	65.65	545.50	505.50	19.985	15.309
2	.59	.27	65.41	545.50	510.00	20.044	15.830
3	.56	.30	65.21	545.50	513.58	20.093	16.267
4	.52	.34	65.04	545.50	517.58	20.156	16.769
5	.49	.34	64.89	545.50	520.68	20.195	17.159

TEMPERATURE (DEG. R)

STREAM LINE	ABSOLUTE RELATIVE	ABSOLUTE RELATIVE	RELATIVE	TEMPERATURE (DEG. R)	TEMPERATURE (DEG. R)	PRESSURE (PSI)	PRESSURE RATIO
1	.63	.26	65.65	545.50	505.50	19.985	15.309
2	.59	.27	65.41	545.50	510.00	20.044	15.830
3	.56	.30	65.21	545.50	513.58	20.093	16.267
4	.52	.34	65.04	545.50	517.58	20.156	16.769
5	.49	.34	64.89	545.50	520.68	20.195	17.159



SET NUMBER PAGE RPM PRESSURE/RATIO INLET TOTAL TEMPERATURE TOTAL  
 (DEG. R)  
 1 2 25000.0 1.400 20.580 545.50

KOTOR EXIT SOLUTION

STREAM LINE	RADIAL POSITION	X=R/RM	SHIFT	RADIAL OPENING	BLADE Y=VA /VAM	EFFICIENCY	LOSS COEFFICIENT	CONTINITY	FRACTION RATE
1	2.693	.825	-.0710	.1912	1.0181	.8812	.1189	.1182	0.0000
2	3.020	.825	-.0168	.2218	1.8317	.8756	.1245	.1245	.2051
3	3.265	1.000	-.0405	.2447	1.0000	.8714	.1287	.1287	.3857
4	3.585	1.098	-.1517	.2742	1.2682	.8796	.1205	.1205	.6822
5	3.837	1.175	-.2100	.2983	1.5106	.8861	.1140	.1140	1.0000

ABSOLUTE VELOCITY (FPS)

STREAM LINE	AXIAL COMPONENT	RADIAL COMPONENT	TANGENTIAL COMPONENT	OVERALL VELOCITY	AXIAL COMPONENT	RADIAL COMPONENT	TANGENTIAL COMPONENT	OVERALL VELOCITY	WHEEL VELOCITY
1	193.70	-7.77	121.36	228.72	193.70	-7.77	-466.14	504.85	587.52
2	158.25	1.75	208.83	235.74	158.25	1.50	-363.52	396.47	656.84
3	130.58	20.96	227.89	248.46	170.28	4.35	-422.42	463.36	712.31
4	241.28	20.96	272.67	368.46	241.28	20.96	-504.64	559.64	837.11
5	287.40	34.10	262.93	371.02	287.40	34.10	-574.17	642.99	837.11

MACH NUMBER

STREAM LINE	FLOW ANGLE (DEG.)		TEMPERATURE (DEG. R)		PRESSURE (PSI)	
	ABSOLUTE	RELATIVE	TOTAL	STATIC	TOTAL	STATIC
1	.21	32.07	493.99	489.64	13.836	13.414
2	.30	61.82	513.13	503.79	15.973	14.978
3	.31	56.72	514.60	504.74	16.086	15.032
4	.33	49.02	516.26	504.97	16.209	15.001
5	.36	42.46	517.08	504.36	16.238	14.882

EQUIVALENT INLET PRESSURE (PSI)

STREAM LINE	EQUIVALENT INLET PRESSURE (PSI)	EQUIV/STATIC PRESSURE RATIO
1	510.85	1.2
2	516.87	1.1
3	522.60	1.2
4	531.03	1.2
5	538.76	1.3



SET NUMBER	PAGE NUMBER	RPM	TOTAL/STATIC PRESSURE RATIO	INLET TOTAL PRESSURE (PSI)	INLET TOTAL TEMPERATURE (DEG. R)
1	3	25000.0	1.400	20.580	545.50

OVERALL TURBINE CHARACTERISTICS

STREAM LINE	PRESSURE RATIO TOT/STA	EFFICIENCY TOT/STA	HEAD COEFFICIENT TOT/TOT	BLADE/JET SPEED RATIO	THEORETICAL DEGREE OF REACTION
1	1.5342	.8204	2.0751	.6942	.2957
2	1.3740	.6838	1.3253	.8686	.1693
3	1.3691	.6598	1.1578	.9294	.2430
4	1.3719	.6205	1.0102	.9950	.3414
5	1.3829	.5889	.9261	1.0391	.4275

MASS AVERAGED QUANTITIES

HORSE POWER =	26.78	(HP)
MOMENT =	5.63	(FT-LB)
FLOW RATE =	2.43	(LB/SEC)
REFERRED RPM =	24371.10	(RPM)
REFERRED HORSE POWER =	18.69	(HP)
REFERRED MOMENT =	4.02	(FT-LB)
REFERRED FLOW RATE =	1.78	(LB/SEC)

TOTAL/STATIC EFFICIENCY =	.6072
TOTAL/TOTAL EFFICIENCY =	.8335
TOTAL/STATIC PRESSURE RATIO =	1.3034
TOTAL/TOTAL PRESSURE RATIO =	1.3034

HEAD COEFFICIENT =	1.2485
BLADE/JET SPEED RATIO =	.8950
THEORETICAL DEGREE OF REACTION =	.2788
MACH NUMBER AT STATION 0 =	.1768





SET PAGE TOTAL/STATIC INLET TOTAL INLET TOTAL  
 NUMBER NUMBER RPM PRESSURE RATIO PRESSURE TEMPERATURE  
 1 1 30000.0 1.400 20.580 545.50

STATOR EXIT SOLUTION

STREAM LINE	RADIAL POSITION (IN)	X=R/RM	RADIAL SHIFT (IN)	BLADE OPENING (IN)	Y=VA./VAM	EFFICIENCY	BLEADE COEFFICIENT	LOSS	ZFIA*	CONTINUITY	FLOW RATE FRACTION
1	2.764	.865	0.0000	.2326	1.1012	.9078	.0922	.0922	.0922		0.0000
2	3.003	.940	0.0000	.2247	1.0468	.9055	.0945	.0945	.0945		.2601
3	3.195	1.000	0.0000	.2245	1.0000	.9036	.0964	.0964	.0964		.4815
4	3.432	1.074	0.0000	.2245	.9403	.9019	.0981	.0981	.0981		.7628
5	3.627	1.135	0.0000	.2326	.8907	.9006	.0994	.0994	.0994		1.0000

RELATIVE VELOCITY (FPS)

STREAM LINE	AXIAL COMPONENT	RADIAL COMPONENT	TANGENTIAL COMPONENT	OVERALL VELOCITY	AXIAL COMPONENT	RADIAL COMPONENT	TANGENTIAL COMPONENT	OVERALL VELOCITY	WHFFI VELOCITY
1	305.04	-12.24	673.85	739.78	305.04	-12.24	-49.77	309.32	723.62
2	289.96	2.75	633.83	696.65	289.96	2.75	-152.78	327.76	786.21
3	280.02	6.34	599.75	660.66	280.02	6.34	-236.83	356.80	836.58
4	260.46	22.62	559.41	617.48	260.46	22.62	-339.00	428.11	898.41
5	246.73	29.27	526.42	582.11	246.73	29.27	-423.13	490.68	949.55

TEMPERATURE (DEG. R)

STREAM LINE	ABSOLUTE	RELATIVE	ABSOLUTE	RELATIVE	TOTAL	STATIC	TOTAL	STATIC	TOT/TOT	TOT/STA
1	.67	.28	65.65	-9.27	545.50	499.96	19.921	14.683	1.0331	1.4016
2	.63	.33	65.41	-27.79	545.50	509.18	19.985	15.648	1.0298	1.4479
3	.60	.39	65.21	-40.73	545.50	513.77	20.100	16.543	1.0271	1.4872
4	.56	.44	65.04	-52.47	545.50	517.30	20.150	16.734	1.0239	1.5236
5	.52	.44	64.89	-59.76	545.50	517.30	20.150	16.734	1.0213	1.5298



SET NUMBER 1 2 30000.0 RPM 1.400 20.580 545.50  
 PRESSURE RATIO 1.400 20.580 545.50  
 INLET TOTAL TEMPERATURE (DEC. R)

ROTOR EXIT SOLUTION

STREAM LINE	RADIAL POSITION	X=R/RM	SHIPT OPENING	BLADE	Y=VA /VAM	EFFICIENCY	LOSS COEFFICIENT	CONTINITY	FLOW RATE FRACTION
1	2.693	.825	.0710	.1912	1.0274	.8819	.1181	.1101	0.0000
2	3.020	.825	-.0168	.2218	1.7995	.8792	.1208	.1208	.1951
3	3.265	1.000	-.0405	.2447	1.0000	.8772	.1228	.1228	.3644
4	3.585	1.098	-.1537	.2747	1.3181	.8871	.1130	.1130	.6008
5	3.837	1.175	-.2100	.2983	1.6051	.8948	.1052	.1052	1.0000

STREAM LINE	AXIAL COMPONENT	RADIAL COMPONENT	TANGENTIAL COMPONENT	OVERALL VELOCITY	AXIAL COMPONENT	RADIAL COMPONENT	TANGENTIAL COMPONENT	OVERALL VELOCITY	WHIPL VELOCITY
1	200.40	-8.04	222.75	299.74	200.40	-8.04	-482.28	522.32	705.03
2	155.94	1.48	433.40	459.66	155.94	1.48	-358.21	396.68	790.61
3	195.05	4.46	421.66	464.61	195.05	4.46	-433.11	475.03	854.78
4	257.10	22.33	401.05	476.91	257.10	22.33	-533.60	596.34	938.65
5	313.08	37.15	379.05	493.03	313.08	37.15	-625.47	700.44	1004.53

STREAM LINE	ABSOLUTE	RELATIVE	ABSOLUTE	RELATIVE	TOTAL	STATIC	TEMPERATURE (DEC. R)	TEMPERATURE (DEC. R)	PRESSURE (PSI)	PRESSURE RATIO
1	.28	.48	48.03	-67.44	490.49	483.01	13.432	13.432	101/101	1.5322
2	.42	.36	70.17	-66.48	519.51	501.93	16.642	16.642	101/101	1.3366
3	.43	.43	65.18	-65.76	521.98	504.16	16.882	16.882	101/101	1.3205
4	.43	.54	57.34	-64.45	524.51	505.58	17.008	17.008	101/101	1.3058
5	.45	.64	50.45	-63.41	525.68	505.45	17.120	17.120	101/101	1.3021

STREAM LINE	EQUIVALENT TEMPERATURE (DEC. R)	EQUIVALENT INLET PRESSURE (PSI)	EQUIV/STATIC PRESSURE RATIO
1	505.71	15.283	1.2
2	514.63	16.299	1.1
3	522.94	17.283	1.2
4	535.18	18.600	1.3
5	546.28	20.251	1.4



SET NUMBER PAGE NUMBER RPM TOTAL/STATIC PRESSURE RATIO INLET TOTAL PRESSURE (PSI) INLET TOTAL TEMPERATURE (DEG. R)

1 3 30000.0 1.400 20.580 545.50

OVERALL TURBINE CHARACTERISTICS

STREAM LINE	PRESSURE RATIO TOT/STA	EFFICIENCY TOT/TOT	HEAD COEFFICIENT	BLADE/JET SPEED RATIO	THEORETICAL DEGREE OF REACTION
1	1.6168	.7863	1.6058	.7891	.2830
2	1.3950	.8092	.9621	1.0195	.0907
3	1.3783	.7790	.8205	1.1040	.1588
4	1.3713	.7392	.7006	1.1947	.2524
5	1.3791	.7092	.6379	1.2521	.3458

MASS AVERAGED QUANTITIES

HORSE POWER = 22.02 (HP)  
 MOMENT = 3.86 (FT-LB)  
 FLOW RATE = 2.53 (LB/SEC)

REFERRED RPM = 29245.32  
 REFERRED HORSE POWER = 15.33 (HP)  
 REFERRED MOMENT = 2.75 (FT-LB)  
 REFERRED FLOW RATE = 1.85 (LB/SEC)

TOTAL/STATIC EFFICIENCY = .7803  
 TOTAL/STATIC PRESSURE RATIO = 1.2575

HEAD COEFFICIENT = .9013  
 BLADE/JET SPEED RATIO = 1.0514  
 THEORETICAL DEGREE OF REACTION = .2061  
 MACH NUMBER AT STATION 0 = .1841



SET NUMBER 1 PAGE NUMBER 1 RPM 5000.0 INITIAL/STATIC PRESSURE RATIO 1.600 INLET TOTAL PRESSURE 23.520 INLET TOTAL TEMPERATURE 562.23

STATOR EXIT SOLUTION

STREAM LINE	RADIAL POSITION (IN)	X=R/RM	RADIAL SHIFT (IN)	KADIAL OPENING (IN)	BLADE ANGLE (DEG)	Y=VA /VAM	EFFICIENCY	LOSS COEFFICIENT	Z/CIAX	CONTINUITY	FLOW RATE FRACTION
1	2.764	.865	0.0000	.2126	1.046	.9106	.0894	.0894	.0894	.0894	0.0000
2	3.003	.940	0.0000	.2157	1.0480	.9041	.0759	.0759	.0759	.0759	.2535
3	3.195	1.000	0.0290	.2227	1.0795	.8906	.1032	.1032	.1032	.1032	.4720
4	3.432	1.074	0.0660	.2265	1.0795	.8946	.1054	.1054	.1054	.1054	.7562
5	3.627	1.135	0.0000	.2226	.8898	.8912	.1088	.1088	.1088	.1088	1.0000

RELATIVE VELOCITY (FPS)

STREAM LINE	AXIAL COMPONENT	RADIAL COMPONENT	TANGENTIAL COMPONENT	OVERALL VELOCITY	AXIAL COMPONENT	RADIAL COMPONENT	TANGENTIAL COMPONENT	OVERALL VELOCITY	WHEEL VELOCITY
1	402.80	-16.16	809.81	976.87	402.80	-16.16	769.21	868.44	120.60
2	382.17	3.63	814.86	918.39	382.17	3.63	702.83	800.90	131.02
3	348.89	8.34	799.52	869.70	358.89	8.34	650.88	742.62	137.43
4	342.61	29.76	745.84	812.24	342.61	29.76	586.11	629.55	147.72
5	324.45	38.49	692.24	765.48	324.46	38.49	533.98	626.81	158.25

TEMPERATURE (DEG. R)

STREAM LINE	ABSOLUTE	RELATIVE	ABSOLUTE	RELATIVE	TOTAL	STATIC	TOTAL	STATIC	101/101	101/STA
1	91	.81	65.65	62.37	562.23	482.82	22.218	33.039	1.0566	1.0029
2	94	.74	65.41	61.50	562.23	492.89	22.298	33.906	1.0548	1.0017
3	79	.68	65.21	61.10	562.23	499.59	22.373	34.265	1.0513	1.0013
4	74	.62	65.04	59.70	562.23	507.33	22.488	35.825	1.0459	1.0005
5	69	.56	64.89	58.72	562.23	513.47	22.580	36.437	1.0416	1.0009





SHI NUMBER	PAGE NUMBER	KPM	TOTAL/STATIC PRESSURE RATIO	INLET TOTAL PRESSURE (PSI)	INLET TOTAL TEMPERATURE (DEG. R)
1	2	5000.0	1.600	23.520	562.23

ROTOR EXIT SOLUTION

STREAM LINE	RADIAL POSITION	X=R/KM	RADIAL SHIFT	BLADE OPENING	BLADE EFFICIENCY	Y=VA /VAM	LOSS COEFFICIENT	CONTINITY	7FF16*	FLOW RATE
1	3.693	.825	.0710	.1912	.7663	.9722	.2337	.2337	0.0000	
2	3.020	.925	-.0168	.2218	.7647	1.0017	.2353	.2353	.2414	
3	3.265	1.000	-.0405	.2447	.7635	1.0000	.2365	.2365	.4445	
4	3.685	1.098	-.1537	.2747	.7654	1.0302	.2346	.2346	.7362	
5	3.037	1.175	-.2100	.2903	.7669	1.0743	.2331	.2331	1.0000	

STREAM LINE	AXIAL COMPONENT	RADIAL COMPONENT	TANGENTIAL COMPONENT	OVERALL VELOCITY	AXIAL COMPONENT	RADIAL COMPONENT	TANGENTIAL COMPONENT	OVERALL VELOCITY	WHEEL VELOCITY
1	260.85	-10.46	-510.24	573.15	260.85	-10.46	-627.75	679.87	117.50
2	268.75	2.55	-485.60	555.02	268.75	2.55	-617.37	673.34	131.77
3	268.30	6.14	-453.30	526.79	268.30	6.14	-595.76	653.42	142.44
4	276.42	24.01	-421.56	504.68	276.42	24.01	-570.00	641.15	156.44
5	288.24	34.20	-408.42	501.06	288.24	34.20	-575.84	644.86	167.42

STREAM LINE	MACH NUMBER	FLOW ANGLE (DEG)	TEMPERATURE (DEG. R)	PRESSURE (PSI)	101/T01	101/STIA
1	.52	-62.93	514.79	17.137	14.260	1.3725
2	.50	-61.04	533.37	17.101	14.321	1.3754
3	.49	-65.38	573.16	17.212	14.702	1.3745
4	.58	-56.75	532.92	17.245	15.105	1.3693
5	.45	-54.79	535.62	17.374	15.104	1.3537

STREAM LINE	EQUIVALENT TEMPERATURE (DEG. R)	EQUIVALENT INLET PRESSURE (PSI)	EQUIVALENT PRESSURE RATIO
1	545.52	18.991	1.4
2	535.27	20.657	1.4
3	545.25	20.095	1.4
4	517.53	20.967	1.4
5	546.33	20.423	1.4



SET NUMBER	PAGE NUMBER	KPM	TOTAL/STATIC PRESSURE RATIO	INLET TOTAL PRESSURE (PSI)	INLET TOTAL TEMPERATURE (DEG. R)
1	3	5000.0	1.600	23.520	562.23

OVERALL TURBINE CHARACTERISTICS

STREAM LINE	PRESSURE RATIO TOT/ST	EFFICIENCY TOT/TOT	HEAD COEFFICIENT	BLADE/JET SPEED RATIO	THEORETICAL DEGREE OF REACTION
1	1.644	.5725	61.8848	.1271	-.1643
2	1.631	.5667	51.5135	.1393	-.0543
3	1.592	.6059	43.6333	.1514	.0079
4	1.573	.6253	35.1130	.1654	.0392
5	1.5572	.6354	32.0649	.1766	.1013

MASS AVERAGED QUANTITIES

HORSE POWER =	30.55	(HP)
MOMENT =	32.09	(FT-LB)
FLOW RATE =	3.10	(LB/SEC)
REFERRED RPM =	4801.15	(RPM)
REFERRED HORSE POWER =	18.33	(HP)
REFERRED MOMENT =	20.06	(FT-LB)
REFERRED FLOW RATE =	2.02	(LB/SEC)

TOTAL/STATIC EFFICIENCY =	.4116
TOTAL/STATIC PRESSURE RATIO =	1.6000
TOTAL/STATIC PRESSURE RATIO =	1.3653

HEAD COEFFICIENT =	44.5508
BLADE/JET SPEED RATIO =	1.498
THEORETICAL DEGREE OF REACTION =	.0128
MACH NUMBER AT STATION 0 =	1.2011



SET PAGE TOTAL/STATIC INLET TOTAL INLET TOTAL  
 NUMBER NUMBER RPM PRESSURE RATIO PRESSURE TEMPERATURE TEMPERATURE  
 1 1 10000.0 1.000 23.520 562.23

STATOR EXIT SOLUTION

STREAM LINE	RADIAL POSITION (IN)	X=R/KM	RADIAL SHIFT (IN)	BLADE OPENING (IN)	BLADE EFFICIENCY	Y=VA /VAM	LOSS COEFFICIENT	ZETA* CONTINUITY	FLUX RATE FRACTION
1	2.784	.865	0.0000	.2126	.9084	1.1044	.0916	.0916	0.0000
2	3.003	.740	0.0000	.2347	.9019	1.0479	.0991	.0901	.2562
3	3.135	1.000	0.0290	.2526	.8968	1.0000	.1032	.1032	.4765
4	3.452	1.074	0.0000	.2745	.8931	.9377	.1069	.1069	.7591
5	3.627	1.135	0.0000	.2926	.8901	.8901	.1099	.1099	1.0000

ABSOLUTE VELOCITY (FPS)

STREAM LINE	AXIAL COMPONENT	RADIAL COMPONENT	TANGENTIAL COMPONENT	OVERALL VELOCITY	AXIAL COMPONENT	RADIAL COMPONENT	TANGENTIAL COMPONENT	OVERALL VELOCITY	WHEEL VELOCITY
1	371.28	-14.09	820.18	900.42	371.28	-14.89	578.97	687.95	241.21
2	362.29	3.35	769.58	846.59	352.29	3.35	507.51	617.81	272.07
3	340.09	7.09	727.85	801.77	320.09	7.69	448.99	551.46	278.86
4	315.91	27.44	628.50	748.94	315.91	27.44	379.03	494.19	269.47
5	299.23	35.50	638.43	705.97	299.23	35.50	321.91	440.94	316.52

RELATIVE VELOCITY (FPS)

STREAM LINE	ABSOLUTE RELATIVE	FLOW ANGLE (DEG. R)	TEMPERATURE (DEG. R)	PRESSURE (PSI)	ABSOLUTE RELATIVE	TEMPERATURE (DEG. R)	PRESSURE (PSI)
1	.83	65.65	562.23	22.407	14.325	1.0497	1.6419
2	.77	55.41	502.62	22.425	15.133	1.0475	1.5491
3	.73	65.21	508.94	22.538	15.884	1.045	1.4807
4	.67	50.19	515.55	22.640	16.716	1.0382	1.4070
5	.63	64.89	520.76	22.720	17.376	1.0352	1.3356



SET NUMBER	KADE NUMBER	RPM	INLET/STATIC PRESSURE RATIO	INLET TOTAL PRESSURE (PSI)	INLET TOTAL TEMPERATURE (DEG. R)
1	2	10000.0	1.600	23.520	562.23

MOTOR EXIT SOLUTION

STREAM LINE	RADIAL POSITION	X=R/RM	SHUFF	RADIAL OPENING	BLADE ANGLE	Y=VA /VAM	EFFICIENCY	LOSS COEFFICIENT	CONTINUITY	FLOW RATE FRACTION
1	2.693	0.25	0.710	1.912	0.792	0.8166	0.1834	0.1834	0.0000	
2	3.120	0.169	0.210	0.9715	0.8199	0.1802	0.3802	0.3802	0.2360	
3	3.725	0.0405	0.447	1.0000	0.8223	0.1777	0.4344	0.4344	0.4344	
4	3.825	1.028	1.537	1.0795	0.8228	0.1673	0.4673	0.4673	0.7270	
5	3.837	1.175	1.2100	1.2983	1.1644	0.8409	0.1591	0.1591	1.0000	

ABSOLUTE VELOCITY (FPS)

STREAM LINE	AXIAL COMPONENT	RADIAL COMPONENT	TANGENTIAL COMPONENT	OVERALL VELOCITY	AXIAL COMPONENT	RADIAL COMPONENT	TANGENTIAL COMPONENT	OVERALL VELOCITY	WHEEL VELOCITY
1	242.02	-9.71	-347.41	423.51	242.02	-9.71	-582.42	630.78	235.01
2	239.94	2.28	-287.63	374.58	239.94	2.28	-551.17	601.14	223.54
3	245.93	5.65	-263.49	361.19	246.88	5.65	-538.42	601.49	214.53
4	267.38	23.14	-244.13	362.07	267.38	23.14	-557.02	617.87	212.28
5	287.60	34.12	-239.71	375.95	287.60	34.12	-574.55	643.42	234.04

MACH NUMBER FLOW ANGLE (DEG)

STREAM LINE	ABSOLUTE	RELATIVE	ABSOLUTE	RELATIVE	TOTAL	STATIC	TOTAL	STATIC	TOT/TOT	TOT/STA
1	0.39	0.58	-55.14	-67.44	515.72	509.79	15.718	14.192	1.4964	1.6584
2	0.34	0.55	-50.17	-66.48	516.05	504.37	15.849	14.672	1.4793	1.6027
3	0.33	0.55	-46.86	-65.76	515.96	504.22	15.945	14.712	1.4751	1.5827
4	0.33	0.56	-42.51	-64.45	515.20	504.79	16.004	14.850	1.4578	1.5836
5	0.34	0.58	-39.81	-63.41	515.24	503.48	16.994	14.752	1.4706	1.5944

EQUIVALENT INLET PRESSURE (PSI)

STREAM LINE	EQUIVALENT INLET PRESSURE (PSI)	EQUIVALENT PRESSURE RATIO
1	533.20	1.3
2	534.44	1.3
3	534.33	1.3
4	536.62	1.3
5	537.93	1.3





SET NUMBER	PAGE NUMBER	RPM	TOTAL/STATIC PRESSURE RATIO	INLET TOTAL PRESSURE (PSI)	INLET TOTAL TEMPERATURE (DEG. R)
1	5	10000.0	1.600	23.520	562.23

OVERALL TURBINE CHARACTERISTICS

STREAM LINE	PRESSURE RATIO TOT/STA	EFFICIENCY TOT/STA	TOT/TOT	HEAD COEFFICIENT	BLADE/JET SPEED RATIO	THEORETICAL DEGREE OF REACTION
1	1.4584	.6148	.7405	15.6275	.2530	.0183
2	1.4097	.6516	.7790	12.4023	.2840	.0675
3	1.5937	.6260	.7630	10.9105	.3079	.1543
4	1.5838	.6722	.7945	9.5752	.3284	.2450
5	1.5944	.6698	.8010	8.4152	.3447	.3358

MASS AVERAGED QUANTITIES

HORSE POWER = 46.12 (HP)  
 MOMENT = 24.25 (FT-LB)  
 FLOW RATE = 2.93 (LB/SEC)

REFERRED RPM = 9602.30  
 REFERRED HORSE POWER = 27.71 (HP)  
 REFERRED MOMENT = 15.16 (FT-LB)  
 REFERRED FLOW RATE = 1.91 (LB/SEC)

TOTAL/STATIC EFFICIENCY = .6555  
 TOTAL/TOTAL EFFICIENCY = .7836  
 TOTAL/STATIC PRESSURE RATIO = 1.6029  
 TOTAL/TOTAL PRESSURE RATIO = 1.4269

HEAD COEFFICIENT = 11.1498  
 BLADE/JET SPEED RATIO = 1.2995  
 THEORETICAL DEGREE OF REACTION = 1.610  
 MACH NUMBER AT STATION 0 = 1.894



SET NUMBER 1 PAGE 1  
 RPM 15000.0  
 TOTAL/STATIC PRESSURE RATIO 1.600  
 INLET TOTAL PRESSURE 23.520  
 INLET TOTAL TEMPERATURE 562.23

STATOR EXIT SOLUTION

STREAM LINE	RADIAL POSITION (IN)	X=R/RM	RADIAL SHIFT (IN)	BLADE OPENING (IN)	Y=VA /VM	BLADE EFFICIENCY	LOSS COEFFICIENT	ZETA% CONTINUITY	FLOW RATE FRACTION
1	2.764	.865	0.0000	.2126	1.0974	.8962	.1038	.1038	0.0000
2	3.003	.940	0.0000	.2347	1.0451	.8964	.1036	.1036	.2575
3	3.195	1.000	0.0290	.2526	1.0000	.8965	.1035	.1035	.4784
4	3.432	1.074	0.0000	.2745	.9417	.8963	.1037	.1037	.7606
5	3.627	1.135	0.0000	.2926	.8931	.8961	.1039	.1039	1.0000

STREAM LINE	ABSOLUTE VELOCITY (FPS)				RELATIVE VELOCITY (FPS)				
	RADIAL COMPONENT	AXIAL COMPONENT	TANGENTIAL VELOCITY	OVERALL VELOCITY	RADIAL COMPONENT	AXIAL COMPONENT	TANGENTIAL COMPONENT	OVERALL VELOCITY	WHEEL VELOCITY
1	332.10	-13.32	733.62	805.40	-13.32	332.10	721.82	494.71	361.81
2	316.36	3.01	671.09	760.06	3.01	316.36	297.08	434.60	293.10
3	317.42	6.93	655.37	731.93	6.93	307.02	237.00	368.54	418.57
4	285.06	24.76	612.23	675.29	24.76	285.06	162.02	328.51	449.20
5	271.33	32.07	576.77	637.79	32.07	270.33	102.00	294.71	474.77

STREAM LINE	MACH NUMBER			FLOW ANGLE (DEG. R)			TEMPERATURE (DEG. R)			PRESSURE (PSI)		
	ABSOLUTE	RELATIVE	RELATIVE	ABSOLUTE	RELATIVE	RELATIVE	TOTAL	STATIC	STATIC	TOTAL	STATIC	STATIC
1	.73	.45	48.23	65.65	48.23	562.23	508.25	508.25	22.523	15.820	1.043	1.457
2	.68	.35	43.29	65.41	43.29	562.23	514.16	514.16	22.642	16.568	1.038	1.407
3	.65	.35	37.64	65.21	37.64	562.23	518.16	518.16	22.735	17.168	1.037	1.371
4	.60	.27	29.77	65.04	29.77	562.23	524.23	524.23	22.836	17.875	1.039	1.315
5	.57	.26	20.67	64.89	20.67	562.23	528.38	528.38	22.914	18.438	1.065	1.275



SET NUMBER PAGE NUMBER RPM INITIAL/STATIC PRESSURE RATIO INLET TOTAL PRESSURE (PSI) INLET TOTAL TEMPERATURE (DEG. R)

1 2 15000.0 1.600 23.520 562.23

KOTOR EXIT SOLUTION

STREAM LINE	RADIAL POSITION	X=R/RM	SHOPE	RADIAL OPENING	BLADE EFFICIENCY	Y=VA /VAM	FLARE COEFFICIENT	LOSS CONTINUITY	FLOW RATE FRACTION
1	3.693	.825	-.0710	.1912	.9084	.8634	.1370	.1370	0.0000
2	3.020	.932	-.0448	.2219	.9247	.8702	.1298	.1298	.2286
3	3.265	1.000	-.0405	.2437	1.0000	.8756	.1245	.1245	.4226
4	3.585	1.098	-.0332	.2737	1.2398	.8815	.1187	.1187	.7179
5	3.837	1.175	-.02100	.2983	1.2392	.8862	.1139	.1139	1.0000

ABSOLUTE VELOCITY (FPS)

STREAM LINE	AXIAL COMPONENT	RADIAL COMPONENT	TANGENTIAL COMPONENT	OVERALL VELOCITY	AXIAL COMPONENT	RADIAL COMPONENT	TANGENTIAL COMPONENT	OVERALL VELOCITY	WHEEL VELOCITY
1	230.29	-9.56	-220.95	325.11	238.29	-9.56	-573.46	621.08	353.51
2	225.30	0.14	-122.38	256.45	225.36	2.14	-517.68	564.61	325.31
3	241.10	3.52	-107.98	264.24	241.10	5.52	-535.37	587.18	427.39
4	269.98	23.45	-95.22	287.74	269.98	23.45	-564.55	626.23	487.33
5	298.76	35.45	-94.60	315.30	298.76	35.45	-596.87	668.41	507.26

MACH NUMBER FLOW ANGLE (DEG. R)

STREAM LINE	ABSOLUTE	RELATIVE	ABSOLUTE	RELATIVE	TOTAL	STATIC	TOTAL	STATIC	TOT/TOT	TOT/STA
1	.30	.57	-42.64	-67.44	505.09	494.30	14.940	14.039	1.5754	1.6753
2	.23	.51	-28.50	-66.48	508.97	503.49	15.547	14.969	1.5712	1.5712
3	.24	.53	-24.13	-65.76	508.93	503.36	15.523	15.004	1.5084	1.5276
4	.26	.57	-19.43	-64.45	509.02	502.16	15.638	14.912	1.5041	1.5273
5	.29	.61	-17.57	-63.41	508.75	500.47	15.616	14.745	1.5061	1.5251

EQUIVALENT INLET PRESSURE (PSI)

STREAM LINE	EQUIVALENT TEMPERATURE (DEG. R)	EQUIVALENT INLET PRESSURE (PSI)	EQUIV/STATIC PRESSURE RATIO
1	528.40	18.126	1.3
2	536.02	18.418	1.2
3	537.05	18.742	1.2
4	534.79	19.168	1.3
5	537.65	19.595	1.3



SET NUMBER	RPM	TOTAL/STATIC PRESSURE RATIO	INLET TOTAL PRESSURE (PSI)	INLET TOTAL TEMPERATURE (DEG. R)
1	15000.0	1.600	23.520	562.23

OVERALL TURBINE CHARACTERISTICS

STREAM LINE	PRESSURE RATIO TOT/STA	EFFICIENCY TOT/STA	HEAD COEFFICIENT TOT/TOT	BLADE/JET SPEED RATIO	THEORETICAL DEGREE OF REACTION
1	1.5753	.8345	2.0747	.3760	.2185
2	1.5712	.7822	5.2953	.4346	.2324
3	1.5676	.8586	4.6545	.4635	.2361
4	1.5773	.7757	4.0076	.4946	.2822
5	1.5951	.8615	3.7435	.5168	.4620

MASS AVERAGED QUANTITIES

HORSE POWER =	54.17	(HP)
MOMENT =	18.97	(FT-LB)
FLOW RATE =	2.97	(LB/SEC)
REFERRED RPM =	14403.46	(RPM)
REFERRED HORSE POWER =	32.51	(HP)
REFERRED MOMENT =	13.86	(FT-LB)
REFERRED FLOW RATE =	1.93	(LB/SEC)

TOTAL/STATIC EFFICIENCY =	.7739
TOTAL/TOTAL EFFICIENCY =	.8532
TOTAL/STATIC PRESSURE RATIO =	1.5878
TOTAL/TOTAL PRESSURE RATIO =	1.5365

HEAD COEFFICIENT =	4.8616
BLADE/JET SPEED RATIO =	.4535
THEORETICAL DEGREE OF REACTION =	.3052
MACH NUMBER AT STATION 0 =	1.0000





SET PAGE TOTAL/STATIC INLET TOTAL INLET TOTAL  
 NUMBER NUMBER PRESSURE RATIO PRESSURE RATIO PRESSURE RATIO PRESSURE RATIO  
 1 1 1.000 1.000 23.520 562.23

STATOR EXIT SOLUTION

STREAM LINE	RADIAL POSITION (IN)	X=R/RM	RADIAL SHIFT (IN)	BLADE OPENING (IN)	BLADE EFFICIENCY	Y=VA /VAM	BLADE EFFICIENCY	LOSS COEFFICIENT	ZETA*	CONTINUITY	FLUX RATE FRACTION
1	2.764	.865	0.0000	.2126	.9033	1.0995	.9033	.0967	.0967	.0967	0.0000
2	3.003	.740	0.0000	.2347	.9019	1.0461	.9019	.0981	.0981	.0981	.2585
3	3.175	1.000	0.0000	.2526	.8999	1.0000	.8999	.0991	.0991	.0991	.4795
4	3.432	1.074	0.0000	.2745	.8998	.9409	.8998	.1002	.1002	.1002	.7614
5	3.627	1.135	0.0000	.2926	.8989	.8917	.8989	.1011	.1011	.1011	1.0000

ABSOLUTE VELOCITY (FPS)

STREAM LINE	AXIAL COMPONENT	RADIAL COMPONENT	TANGENTIAL COMPONENT	OVERALL VELOCITY	AXIAL COMPONENT	RADIAL COMPONENT	TANGENTIAL COMPONENT	OVERALL VELOCITY	TANGENTIAL COMPONENT	OVERALL VELOCITY	WHEEL VELOCITY
1	326.89	-13.11	722.13	792.78	326.89	-13.11	239.72	405.58	239.72	405.58	482.41
2	311.01	2.95	679.40	747.21	311.01	2.95	155.26	347.62	155.26	347.62	524.14
3	302.56	6.80	643.70	709.08	302.56	6.80	85.98	314.61	85.98	314.61	557.72
4	279.73	24.29	600.78	663.15	279.73	24.29	1.84	280.79	1.84	280.79	598.94
5	265.11	31.45	565.62	625.46	265.11	31.45	-67.41	275.35	-67.41	275.35	633.03

MACH NUMBER FLOW ANGLE (DEG)

STREAM LINE	ABSOLUTE	RELATIVE	TEMPERATURE (DEG. R)	STATIC	TOTAL	STATIC	TOTAL	STATIC	TOTAL	101/TOT	101/STA
1	.72	.37	562.23	502.93	562.23	502.93	22.628	16.078	22.628	1.0394	1.4628
2	.67	.28	562.23	25.77	562.23	25.77	22.723	19.593	22.723	1.0350	1.3728
3	.63	.21	562.23	20.39	562.23	20.39	22.600	17.994	22.600	1.0318	1.3522
4	.59	.25	562.23	22.64	562.23	22.64	22.888	18.084	22.888	1.0276	1.3006
5	.55	.24	562.23	22.68	562.23	22.68	22.956	18.631	22.956	1.0246	1.2624



SET PAGE RPM TOTAL/STATIC INLET TOTAL INLET TOTAL  
 NUMBER NUMBER PRESSURE RATIO PRESSURE TEMPERATURE PRESSURE TEMPERATURE  
 (DEG. R) (DEG. R)

1 2 20000.0 1.600 23.520 562.23

ROTOR EXIT SOLUTION

STREAM LINE	RADIAL POSITION	X=R/RM	SHIFT	RADIAL SHIFT	BLADE OPENING	Y=VA/VUM	EFFICIENCY	LOSS COEFFICIENT	CONTINUITY	FLOW RATE FRACTION
1	3.693	.825	-.0710	.1912	.9981	.8897	.1111	.1111	.1111	0.0000
2	3.020	.920	-.0168	.2218	.8994	.8926	.1074	.1074	.1074	.2215
3	3.265	1.000	-.0405	.2447	1.0000	.8754	.1046	.1046	.1046	.4105
4	3.585	1.098	-.0537	.2747	1.0997	.8043	.1157	.1157	.1157	.7083
5	3.837	1.175	-.2100	.2983	1.3310	.8756	.1245	.1245	.1245	1.0000

ABSOLUTE VELOCITY (FPS)

STREAM LINE	AXIAL COMPONENT	TANGENTIAL COMPONENT	OVERALL VELOCITY	AXIAL COMPONENT	RADIAL COMPONENT	TANGENTIAL COMPONENT	OVERALL VELOCITY	WHEEL VELOCITY
1	234.59	-94.41	253.10	234.59	-9.41	-564.55	611.42	470.02
2	211.40	41.47	215.44	211.40	2.01	-485.61	529.63	529.07
3	235.03	47.96	239.94	235.03	3.38	-521.89	573.40	569.85
4	274.92	50.90	280.61	274.92	23.88	-574.87	637.68	635.95
5	312.84	44.70	318.19	312.84	37.12	-624.98	699.89	669.68

MACH NUMBER FLOW ANGLE (DEG)

STREAM LINE	ABSOLUTE	RELATIVE	ABSOLUTE	RELATIVE	TEMPERATURE (DEG. R)	TEMPERATURE (DEG. R)	STATIC	TOTAL	STATIC	TOTAL	101/TOT	101/STA
1	.23	.56	-21.95	-67.44	496.86	507.65	491.53	14.279	13.750	1.6472	1.7106	
2	.20	.48	11.10	-66.48	506.60	507.50	502.74	15.474	15.065	1.5200	1.5612	
3	.22	.52	11.53	-65.76	507.03	507.65	502.50	15.531	15.051	1.5144	1.5627	
4	.26	.58	10.49	-64.45	507.65	507.65	501.09	15.519	14.830	1.5155	1.5860	
5	.29	.64	8.13	-63.41	507.62	507.62	499.20	15.411	14.535	1.5262	1.6182	

EQUIVALENT INLET PRESSURE (PSI)

STREAM LINE	EQUIVALENT TEMPERATURE (DEG. R)	EQUIVALENT INLET PRESSURE (PSI)	EQUIV/STATIC PRESSURE RATIO
1	522.64	17.525	1.3
2	526.08	18.008	1.2
3	529.77	18.515	1.2
4	534.93	19.229	1.3
5	539.96	19.928	1.4



SET NUMBER	PAGE NUMBER	RPM	TOTAL/STATIC PRESSURE RATIO	INLET TOTAL PRESSURE (PSI)	INLET TOTAL TEMPERATURE (DEG. R)
1	3	20000.0	1.600	23.520	562.23

OVERALL TURBINE CHARACTERISTICS

STREAM LINE	PRESSURE RATIO TOT/STA	EFFICIENCY TOT/TOT	HEAD COEFFICIENT	BLADE/JET SPEED RATIO	THEORETICAL DEGREE OF REACTION
1	1.7106	.8177	4.1282	.4922	.2757
2	1.5200	.8776	2.9392	.5833	.2334
3	1.5627	.8199	2.6011	.6200	.3102
4	1.5860	.7864	2.3264	.6558	.4141
5	1.6182	.7560	2.1662	.6794	.4987

MASS AVERAGED QUANTITIES

HORSE POWER = 56.33 (HP)  
 MOMENT = 14.79 (FT-LB)  
 FLOW RATE = 2.95 (LB/SEC)

REFERRED RPM = 19204.61  
 REFERRED HORSE POWER = 33.81 (HP)  
 REFERRED MOMENT = 9.25 (FT-LB)  
 REFERRED FLOW RATE = 1.92 (LB/SEC)

TOTAL/STATIC EFFICIENCY = .8052  
 TOTAL/TOTAL EFFICIENCY = .8717  
 TOTAL/STATIC PRESSURE RATIO = 1.5342

HEAD COEFFICIENT = 2.7532  
 BLADE/JET SPEED RATIO = .6027  
 THEORETICAL DEGREE OF REACTION = .3362  
 MACH NUMBER AT STATION 0 = .1912



SET NUMBER 1  
 PAGE NUMBER 1  
 RPM 25000.0  
 TOTAL/STATIC PRESSURE RATIO 1.600  
 INLET TOTAL PRESSURE 23.520  
 INLET TOTAL TEMPERATURE 562.23

STATOR EXIT SOLUTION

STREAM LINE	RADIAL POSITION (IN)	X=R/RM SHIFT (IN)	RADIAL OPENING (IN)	BLADE Y=VA /VAM EFFICIENCY	BLADE COEFFICIENT	LOSS CONTINUITY	FLOW RATE FRACTION
1	2.764	.865	.2426	1.1009	.9084	.0916	0.0000
2	3.001	.940	.2347	1.0427	.9063	.0937	.2584
3	3.195	1.000	.2297	1.0000	.9077	.0953	.4794
4	3.432	1.074	.2245	.9403	.9031	.0969	.7613
5	3.627	1.135	.2226	.8908	.9018	.0982	1.0000

STREAM LINE	ABSOLUTE VELOCITY (FPS)				RELATIVE VELOCITY (FPS)			
	RADIAL COMPONENT	TANGENTIAL COMPONENT	OVERALL VELOCITY	AXIAL COMPONENT	RADIAL COMPONENT	TANGENTIAL COMPONENT	OVERALL VELOCITY	WHEEL VELOCITY
1	332.96	735.53	807.49	332.26	-13.36	132.52	358.61	603.01
2	316.55	691.51	760.53	316.55	3.01	36.34	318.65	655.17
3	302.44	654.81	721.32	302.44	6.92	-42.34	305.47	697.15
4	284.39	610.80	674.22	284.39	24.70	-137.87	317.01	746.67
5	269.41	574.81	635.61	269.41	31.96	-216.49	347.09	791.29

STRFAM LINE	MACH NUMBER			TEMPERATURE (DEG. R)			PRESSURE (PSI)		
	ABSOLUTE	RELATIVE	RELATIVE	TOTAL	STATIC	STATIC	TOTAL	STATIC	STATIC
1	.73	.32	21.70	562.23	507.97	507.97	22.646	15.875	15.875
2	.68	.29	6.55	562.23	514.10	514.10	22.733	16.620	16.620
3	.65	.27	-7.97	562.23	518.93	518.93	22.804	17.527	17.527
4	.60	.28	-25.87	562.23	524.40	524.40	22.889	17.937	17.937
5	.56	.31	-38.79	562.23	528.61	528.61	22.955	18.499	18.499





SET NUMBER    KPM    KPM    INLET/STATIC PRESSURE RATIO    INLET TOTAL PRESSURE (PSI)    INLET TOTAL TEMPERATURE (DEG. R)

1    2    25000.0    1.600    23.520    562.23

ROTOR EXII SOLUTION

STREAM LINE	RADIAL POSITION	X=R/RM	SHIPT	RADIAL OPENING	BLADE ANGLE (DEG)	Y=VA /VAM	EFFICIENCY	LOSS COEFFICIENT	CONTINUTY	FRACTION RATE
1	3.693	.825	-.0710	.1912	1.0078	.9043	.0960	.0960	.0960	0.0000
2	3.070	.825	-.0468	.2218	.8666	.8045	.1955	.1955	.1955	.2132
3	3.245	1.000	-.0405	.2417	1.0000	.8704	.1297	.1297	.1297	.3955
4	3.585	1.098	-.1537	.2747	1.2198	.8296	.1704	.1704	.1704	.6949
5	3.637	1.175	-.2100	.2983	1.4240	.8069	.1932	.1932	.1932	1.0000

ABSOLUTE VELOCITY (FPS)

RELATIVE VELOCITY (FPS)

STREAM LINE	AXIAL COMPONENT	RADIAL COMPONENT	TANGENTIAL COMPONENT	OVERALL VELOCITY	AXIAL COMPONENT	RADIAL COMPONENT	TANGENTIAL COMPONENT	OVERALL VELOCITY	WHEEL VELOCITY
1	233.41	-9.46	25.81	235.02	233.41	-9.46	-561.73	608.45	597.52
2	209.70	1.71	197.80	281.90	200.70	1.91	-461.04	502.83	258.84
3	235.59	5.20	198.07	304.78	281.59	5.30	-514.95	564.92	713.21
4	285.50	24.54	191.49	342.17	282.50	24.54	-570.73	655.25	783.21
5	329.78	39.13	178.27	376.92	329.78	39.13	-656.83	737.80	837.11

MACH NUMBER    FLOW ANGLE (DEG)

TEMPERATURE (DEG. R)

PRESSURE RATIO

STREAM LINE	ABSOLUTE	RELATIVE	ABSOLUTE	RELATIVE	TOTAL	STATIC	TOTAL	STATIC	TOT/TOT	TOT/STA
1	.22	.56	61.31	-67.44	490.24	465.34	13.757	13.312	1.7076	1.7669
2	.26	.46	44.59	-66.48	508.52	501.91	13.692	14.930	1.4983	1.5590
3	.28	.51	40.54	-65.76	509.74	501.01	14.741	14.921	1.4942	1.5763
4	.31	.60	34.13	-64.45	511.05	501.31	15.816	14.805	1.4852	1.5887
5	.34	.67	28.40	-63.41	511.37	499.55	15.815	14.572	1.4822	1.6141

EQUIVALENT INLET PRESSURE (PSI)

EQUIV/STATIC PRESSURE RATIO

1	517.14	1.3
2	528.95	1.2
3	528.48	1.2
4	537.04	1.3
5	544.84	1.4



SET NUMBER    PAGE NUMBER    RPM    TOTAL/STATIC PRESSURE RATIO    INLET TOTAL PRESSURE (PSI)    INLET TOTAL TEMPERATURE (DEG. R)

1    3    25000.0    1.600    23.520    562.23

OVERALL TURBINE CHARACTERISTICS

STREAM LINE	PRESSURE RATIO TO/STA	EFFICIENCY TO/TOT	HEAD COEFFICIENT	BLADE/TIP SPEED RATIO	THEORETICAL DEGREE OF REACTION
1	1.7669	.8226	2.7008	.5088	.2922
2	1.5690	.8750	1.9008	.7253	.2747
3	1.5263	.8614	1.4908	.7683	.3018
4	1.5807	.8518	1.4933	.8293	.3986
5	1.6141	.8430	1.3776	.8534	.4314

MASS AVERAGED QUANTITIES

HORSE POWER = 53.63 (HP)  
 MOMENT = 13.22 (FT-LB)  
 FLOW RATE = 2.92 (LB/SEC)

REFERRED RPM = 24005.76 (RPM)  
 REFERRED HORSE POWER = 32.19 (HP)  
 REFERRED MOMENT = 7.04 (FT-LB)  
 REFERRED FLOW RATE = 1.90 (LB/SEC)

TOTAL/STATIC EFFICIENCY = .7670  
 TOTAL/STATIC PRESSURE RATIO = 1.6641  
 TOTAL/STATIC PRESSURE RATIO = 1.6061  
 TOTAL/STATIC PRESSURE RATIO = 1.5192

HEAD COEFFICIENT = 1.7933  
 BLADE/TIP SPEED RATIO = 1.7468  
 THEORETICAL DEGREE OF REACTION = .3263  
 MACH NUMBER AT STATION 0 = .1889



SET PAGE RPM TOTAL/STATIC INLET TOTAL INLET TOTAL  
 NUMBER NUMBER 30000.0 PRESSURE RATIO PRESSURE TEMPERATURE  
 1 1 1.600 23.520 562.23 562.23

STATOR EXIT SOLUTION

STREAM LINE	RADIAL POSITION (IN)	X=R/RM	RADIAL SHUFT (IN)	BLADE OPENING (IN)	BLADE EFFICIENCY	Y=VA /VAM	LOSS COEFFICIENT	ZETA* CONTINUITY	FLOW RATE FRACTION
1	2.764	.865	0.0000	.2126	.9121	1.1019	.0879	.0879	0.0000
2	3.003	.940	0.0000	.2347	.9094	1.0471	.0906	.0906	.2580
3	3.195	1.000	0.0290	.2526	.9072	1.0000	.0928	.0928	.4789
4	3.432	1.074	0.0000	.2745	.9053	.9400	.0947	.0947	.7609
5	3.627	1.135	0.0000	.2926	.9038	.8902	.0962	.0962	1.0000

STREAM LINE	ABSOLUTE VELOCITY (FPS)					RELATIVE VELOCITY (FPS)				
	AXIAL COMPONENT	RADIAL COMPONENT	TANGENTIAL COMPONENT	OVERALL VELOCITY	AXIAL COMPONENT	RADIAL COMPONENT	TANGENTIAL COMPONENT	OVERALL VELOCITY	WHEEL VELOCITY	
1	341.40	-13.69	754.17	827.96	341.40	-13.69	30.56	343.04	723.62	
2	324.41	3.08	708.67	779.40	324.41	3.08	-77.53	333.56	706.21	
3	305.59	7.09	670.80	738.93	305.59	7.09	-165.70	342.73	836.58	
4	291.23	25.29	625.48	690.42	291.23	25.29	-272.93	399.93	898.41	
5	275.81	32.72	588.46	650.71	275.81	32.72	-361.09	455.55	949.55	

STREAM LINE	MACH NUMBER		FLOW ANGLE (DEG)		TEMPERATURE (DEG. R)		PRESSURE (PBT)		PRESSURE RATIO	
	ABSOLUTE	RELATIVE	ABSOLUTE	RELATIVE	TOTAL	STATIC	TOTAL	STATIC	101/10T	101/STIA
1	.75	.31	65.65	5.12	562.23	505.19	22.616	15.566	1.0391	1.5110
2	.70	.30	65.41	-13.44	562.23	511.68	22.719	16.328	1.0352	1.4865
3	.66	.31	65.21	-28.48	562.23	517.80	22.788	16.928	1.0331	1.4625
4	.62	.36	65.04	-43.15	562.23	523.56	22.873	17.706	1.0283	1.4384
5	.58	.40	64.89	-52.63	562.23	527.00	22.939	18.290	1.0253	1.4260



SET PAGE RPM INITIAL/STATIC INLET TOTAL INLET TOTAL  
 NUMBER NUMBER PRESSURE RATIO PRESSURE PRESSURE TEMPERATURE TEMPERATURE  
 (DEG. R) (DEG. R)

1 2 30000.0 1.600 23.520 562.23

KOTOR EXIT SOLUTION

STREAM LINE	RADIAL POSITION	X=R/RM	RADIAL SHIFT	BLADE OPENING	Y=VA	WAM EFFICIENCY	COEFFICIENT LOSS	CONTINUITY	FRACTION RATE
1	3.693	.825	-.0710	.1912	1.0172	.8859	.1142	.1142	0.0000
2	3.620	.925	-.0168	.2218	1.0324	.8803	.1197	.1197	.2019
3	3.265	1.000	-.0405	.2447	1.0000	.8761	.1239	.1239	.3775
4	3.585	1.098	-.0537	.2727	1.0235	.8864	.1136	.1136	.6802
5	3.837	1.175	-.0210	.2983	1.0233	.8946	.1055	.1055	1.0000

ABSOLUTE VELOCITY (FPS)

RELATIVE VELOCITY (FPS)

STREAM LINE	AXIAL COMPONENT	RADIAL COMPONENT	TANGENTIAL COMPONENT	OVERALL VELOCITY	AXIAL COMPONENT	RADIAL COMPONENT	TANGENTIAL COMPONENT	OVERALL VELOCITY	WUFFEL VELOCITY
1	230.49	-9.25	150.36	275.35	230.49	-9.25	-554.67	600.72	705.03
2	189.52	1.79	357.56	404.22	189.52	1.79	-433.05	472.31	790.61
3	226.47	5.18	351.91	418.51	226.47	5.18	-502.87	551.54	854.78
4	288.41	25.05	335.58	443.19	288.41	25.05	-603.88	668.96	938.65
5	344.98	40.93	315.33	469.17	344.98	40.93	-689.19	771.80	1004.53

MACH NUMBER FLOW ANGLE (DEG)

TEMPERATURE (DEG. R) PRESSURE (PSI) PRESSURE RATIO

STREAM LINE	ABSOLUTE	RELATIVE	ABSOLUTE	RELATIVE	TOTAL	STATIC	TOTAL	STATIC	TOTAL	STATIC	10T/10T	10T/STA
1	.26	.56	33.12	-67.44	489.05	482.74	13.508	12.908	1.7411	1.8221	1.4174	1.5561
2	.37	.43	62.20	-66.48	516.55	502.95	16.594	15.115	1.4011	1.5504	1.4011	1.5504
3	.38	.50	57.24	-65.76	518.90	504.11	16.786	15.173	1.3865	1.5501	1.3865	1.5501
4	.40	.61	49.33	-64.45	521.13	504.79	16.976	14.581	1.3854	1.5700	1.3854	1.5700
5	.43	.70	42.43	-63.41	521.95	503.64	16.976	14.581	1.3854	1.5700	1.3854	1.5700

EQUIVALENT INLET PRESSURE (PSI) EQUIVALENT TEMPERATURE (DEG. R)

STREAM LINE	EQUIVALENT INLET PRESSURE (PSI)	EQUIVALENT TEMPERATURE (DEG. R)
1	16.399	512.77
2	17.464	521.52
3	18.463	529.42
4	20.123	542.03
5	21.676	553.20





SET NUMBER	PAGE NUMBER	KPH	TOTAL/STATIC PRESSURE RATIO	INLET TOTAL PRESSURE (PSI)	INLET TOTAL TEMPERATURE (DEG. R)
1	3	30000.0	1.600	23.520	562.23

OVERALL TURBINE CHARACTERISTICS

STREAM LINE	PRESSURE RATIO TOT/STA	RATIO TOT/TOT	EFFICIENCY TOT/STA	TOT/TOT	HEAD COEFFICIENT	BLADE/TIP SPEED RATIO	THEORETICAL DEGREE OF REACTION
1	1.8221	1.7411	.8263	.8884	2.0327	.7014	.2938
2	1.5561	1.4174	.6876	.8565	1.2972	.8780	.1669
3	1.5504	1.4011	.6545	.8390	1.1368	.9379	.2435
4	1.5501	1.3865	.6210	.8200	.9854	1.0074	.3380
5	1.5700	1.3854	.5925	.8055	.9060	1.0506	.4265

MASS AVERAGED QUANTITIES

HORSE POWER =	45.44 (HP)
MOMENT =	7.96 (FT-LB)
FLOW RATE =	2.93 (LB/SEC)
REFERRED RPM =	28806.91
REFERRED HORSE POWER =	27.27 (HP)
REFERRED MOMENT =	4.97 (FT-LB)
REFERRED FLOW RATE =	1.91 (LB/SEC)

TOTAL/STATIC EFFICIENCY =	.6474
TOTAL/STATIC EFFICIENCY =	.8406
TOTAL/STATIC PRESSURE RATIO =	1.5082
TOTAL/STATIC PRESSURE RATIO =	1.4421

HEAD COEFFICIENT =	1.2322
BLADE/TIP SPEED RATIO =	.8025
THEORETICAL DEGREE OF REACTION =	.2771
MACH NUMBER AT STATION 0 =	.1898



SET PAGE RPM TOTAL/STATIC INLET TOTAL INLET TOTAL  
 NUMBER NUMBER 5000.0 PRESSURE RATIO PRESSURE TEMPERATURE  
 1 1 1.800 26.460 557.30

STATOR EXIT SOLUTION

STREAM LINE	RADIAL POSITION (IN)	X=R/RM	RADIAL SHIFT (IN)	BLADE OPENING	Y=VA /VAM	EFFICIENCY	LOSS COEFFICIENT	ZETA*	CONTINUITY	FLOW RATE FRACTION
1	2.764	.865	0.0000	.2326	1.1053	.9157	.0843	.0843	.0000	0.0000
2	3.063	.740	0.0000	.2347	1.0484	.9088	.0912	.0912	.2504	.2504
3	3.192	1.000	0.0000	.2790	1.0000	.9033	.0967	.0967	.4689	.4689
4	3.432	1.074	0.0000	.2745	.9390	.8983	.1017	.1017	.7530	.7530
5	3.627	1.135	0.0000	.2926	.8888	.8941	.1059	.1059	1.0000	1.0000

RELATIVE VELOCITY (FPS)

ABSOLUTE VELOCITY (FPS)

STREAM LINE	AXIAL COMPONENT	RADIAL COMPONENT	TANGENTIAL COMPONENT	OVERALL VELOCITY	AXIAL COMPONENT	RADIAL COMPONENT	TANGENTIAL COMPONENT	OVERALL VELOCITY	WHFEL VELOCITY
1	439.17	-17.62	970.14	1065.06	439.17	-17.62	849.54	956.50	120.60
2	416.55	3.96	909.97	1000.79	416.55	3.96	778.93	883.33	131.03
3	402.67	9.09	860.27	947.64	402.67	9.09	720.84	825.73	139.43
4	373.11	32.41	801.34	884.53	373.11	32.41	651.60	751.66	149.73
5	353.15	41.90	753.46	833.17	353.15	41.90	595.20	693.35	158.26

MACH NUMBER

FLOW ANGLE (DEG)

TEMPERATURE (DEG. R)

PRESSURE RATIO

STREAM LINE	ABSOLUTE	RELATIVE	ABSOLUTE	RELATIVE	TOTAL	STATIC	TOTAL	STATIC	101/101	101/91A
1	1.01	.91	65.65	62.67	557.30	462.91	24.762	12.933	1.0686	2.0459
2	.94	.83	65.41	61.87	557.30	473.59	24.662	12.107	1.0603	1.9262
3	.88	.77	65.21	60.82	557.30	483.59	24.557	15.078	1.0540	1.7940
4	.81	.69	65.04	60.21	557.30	492.20	25.249	17.249	1.0543	1.6395
5	.76	.63	64.89	59.32	557.30	498.54	25.213	17.191	1.0495	1.5392



SET NUMBER KAGE NUMBER RPM TOTAL/STATIC PRESSURE RATIO INLETTOTAL PRESSURE (PSI) INLETTOTAL TEMPERATURE (DEC. R) TOTAL TEMPERATURE (DEC. R)

1 2 5000.0 1.800 26.460 557.30

ROTOR EXIT SOLUTION

STREAM LINE	RADIAL POSITION	X=R/RM	SHIFT	RADIAL OPENING	BLADE EFFICIENCY	Y=VA /VAM	LOSS COEFFICIENT	ZETA*	CONTINUITY	FLOW RATE FRACTION
1	2.693	.825	.0710	.1912	.7723	.9717	.2278	.2278	.2278	0.0000
2	3.020	.925	-.0168	.2218	.7702	1.0028	.2298	.2298	.2298	.2402
3	3.265	1.000	-.0405	.2447	.7687	1.0000	.2313	.2313	.2313	.4435
4	3.585	1.098	-.1537	.2747	.7666	1.0235	.2335	.2335	.2335	.7363
5	3.837	1.175	-.2100	.2983	.7649	1.0613	.2352	.2352	.2352	1.0000

RELATIVE VELOCITY (FPS)

STREAM LINE	AXIAL COMPONENT	RADIAL COMPONENT	TANGENTIAL COMPONENT	OVERALL VELOCITY	AXIAL COMPONENT	RADIAL COMPONENT	TANGENTIAL COMPONENT	OVERALL VELOCITY	WHEEL VELOCITY
1	298.76	-11.98	-601.46	671.68	298.76	-11.98	-718.97	778.66	117.50
2	308.34	-2.93	-576.53	653.81	308.34	2.93	-708.29	772.50	131.77
3	307.47	7.04	-540.27	621.68	307.47	7.04	-682.74	748.81	142.44
4	314.69	27.33	-501.59	592.77	314.69	27.33	-658.63	729.92	152.44
5	326.33	38.72	-484.51	585.44	326.33	38.72	-651.94	730.08	167.42

TEMPERATURE (DEC. R)

TEMPERATURE (DEC. R)

FLOW ANGLE (DEC)

STREAM LINE	ABSOLUTE	RELATIVE	ABSOLUTE	RELATIVE	TOTAL	STATIC	TOTAL	STATIC	101/101	101/51A
1	.62	.72	-63.59	-67.44	526.07	488.52	18.159	14.014	1.4571	1.8047
2	.60	.71	-61.87	-66.48	524.81	489.24	18.021	14.153	1.4225	1.8097
3	.57	.69	-60.36	-65.76	524.53	492.72	18.244	14.457	1.4203	1.8053
4	.54	.67	-57.90	-64.45	524.27	495.03	18.327	15.049	1.4383	1.7862
5	.54	.67	-56.04	-63.41	523.96	495.44	18.425	15.147	1.4361	1.7468

EQUIV/STATIC PRESSURE RATIO

STREAM LINE	EQUIVALENT INLETT PRESSURE (PSI)	EQUIV/STATIC PRESSURE RATIO
1	22.027	1.6
2	22.164	1.6
3	22.259	1.6
4	22.384	1.5
5	22.547	1.5



SET NUMBER	PAGE NUMBER	KPM	TOTAL/STATIC PRESSURE RATIO	INLET TOTAL PRESSURE (PSI)	INLET TOTAL TEMPERATURE (DEG. R)
1	3	5000.0	1.600	26.460	557.30

OVERALL TURBINE CHARACTERISTICS

STREAM LINE	PRESSURE RATIO TOT/STN	TOT/STA	EFFICIENCY TOT/TOT	HEAD COEFFICIENT	SPEED RATIO	THEORETICAL DEGREE OF REACTION
1	1.6862	3375	5496	76.4640	1.144	-1.139
2	1.9697	3561	5664	63.8575	1.251	-1.051
3	1.8054	3787	5835	53.4993	1.367	-1.042
4	1.7532	3980	6009	44.4777	1.499	-1.266
5	1.7460	4062	6091	39.3929	1.593	-1.2181

MASS AVERAGED QUANTITIES

HORSE POWER = 40.80 (HP)  
 MOMENT = 42.85 (FT-LB)  
 FLOW RATE = 3.68 (LB/SEC)

REFERRED KPM = 4822.34 (HP)  
 REFERRED HORSE POWER = 21.86 (HP)  
 REFERRED MOMENT = 23.81 (FT-LB)  
 REFERRED FLOW RATE = 2.32 (LB/SEC)

TOTAL/STATIC EFFICIENCY = .3761  
 TOTAL/TOTAL EFFICIENCY = .5625  
 TOTAL/STATIC PRESSURE RATIO = 1.6127  
 TOTAL/TOTAL PRESSURE RATIO = 1.4494

HEAD COEFFICIENT = 54.9407  
 BLADE/JET SPEED RATIO = 1.249  
 THEORETICAL DEGREE OF REACTION = .0538  
 MACH NUMBER AT STATION 0 = .2117





SET PAGE RPM TOTAL/STATIC INLET TOTAL  
 NUMBER 1 10000.0 PRESSURE RATIO PRESSURE TEMPERATURE  
 1 1.800 26.460 557.30

STATOR EXIT SOLUTION

STREAM LINE	RADIAL POSITION (IN)	X=R/RM	RADIAL SHIFT (IN)	BLADE OPENING (IN)	Y=VA /VAM	BLADE EFFICIENCY	LOSS COEFFICIENT	ZETA* CONTINUITY	FLOW RATE FRACTION
1	2.764	.865	0.0000	.2126	1.1035	.9052	.0948	.0940	0.0000
2	2.003	.940	0.0000	.2347	1.0475	.8991	.1009	.1009	.2544
3	3.195	1.000	0.0000	.2526	1.0000	.8942	.1058	.1058	.4742
4	3.432	1.074	0.0000	.2745	.8940	.8885	.1089	.1089	.7575
5	3.627	1.135	0.0000	.2925	.8910	.8885	.1115	.1115	1.0000

ABSOLUTE VELOCITY (FPS)

STREAM LINE	AXIAL COMPONENT	RADIAL COMPONENT	TANGENTIAL COMPONENT	OVERALL VELOCITY	AXIAL COMPONENT	RADIAL COMPONENT	TANGENTIAL COMPONENT	OVERALL VELOCITY	WHEEL VELOCITY
1	387.07	-15.53	855.05	938.71	387.07	-15.53	613.85	725.86	241.21
2	367.44	3.49	802.69	882.60	367.44	3.49	540.62	653.68	262.07
3	350.74	8.03	759.46	836.60	350.74	8.03	480.60	575.05	278.86
4	329.01	28.64	708.32	781.89	329.01	28.64	408.88	526.10	297.47
5	312.54	37.08	660.82	737.56	312.54	37.08	350.30	470.92	316.52

MACH NUMBER FLOW ANGLE (DEG. R) TEMPERATURE (DEG. R) PRESSURE RATIO

STREAM LINE	ABSOLUTE	RELATIVE	ABSOLUTE	RELATIVE	TOTAL	STATIC	TOTAL	STATIC	TOT/TOT	TOT/STA
1	.87	.67	65.65	57.77	557.30	483.98	25.020	15.270	1.0576	1.7378
2	.81	.60	65.41	55.80	557.30	492.45	25.117	16.290	1.0535	1.6243
3	.76	.54	65.21	53.88	557.30	499.06	25.204	17.127	1.0499	1.5439
4	.71	.48	65.04	51.11	557.30	506.43	25.340	18.126	1.0442	1.4698
5	.66	.42	64.89	48.26	557.30	512.06	25.447	18.921	1.0398	1.3985



SET PAGE RPM TOTAL/STATIC INLET TOTAL INLET TOTAL  
 NUMBER NUMBER PRESSURE RATIO PRESSURE (PSI) TEMPERATURE (DEG. R) TEMPERATURE (DEG. R)

1 2 10000.0 1.800 26.460 557.30

ROTOR EXIT SOLUTION

STREAM LINE	RADIAL POSITION	X=R/RM	SHIFT	BLADE OPENING	Y=VA /VAM	EFFICIENCY	COEFFICIENT LOSS	CONTINUITY	FLOW RATE FRACTION
1	2.693	.825	.0710	.1912	.9284	.8232	.1768	.1768	0.0000
2	3.020	.925	.0168	.2218	.9754	.8245	.1755	.1755	.2363
3	3.265	1.000	.0405	.2447	1.0000	.8255	.1745	.1745	.4364
4	3.585	1.098	.1537	.2747	1.0638	.8335	.1666	.1666	.7296
5	3.837	1.175	.2100	.2983	1.1358	.8397	.1603	.1603	1.0000

RELATIVE VELOCITY (FPS)

STREAM LINE	AXIAL COMPONENT	RADIAL COMPONENT	TANGENTIAL COMPONENT	OVERALL VELOCITY	AXIAL COMPONENT	RADIAL COMPONENT	TANGENTIAL COMPONENT	OVERALL VELOCITY	WHEEL VELOCITY
1	279.90	-11.23	-438.57	520.40	279.90	-11.23	-673.58	729.51	335.01
2	279.04	-2.65	-377.45	469.40	279.04	-2.65	-640.98	699.09	363.54
3	286.08	6.55	-350.30	452.32	286.08	6.55	-635.23	696.71	284.93
4	304.34	26.43	-323.50	444.94	304.34	26.43	-636.39	708.61	313.08
5	324.93	38.55	-314.30	453.71	324.93	38.55	-649.14	726.95	334.84

MACH NUMBER FLOW ANGLE (DEG)

STREAM LINE	ABSOLUTE	RELATIVE	ABSOLUTE	RELATIVE	TEMPERATURE (DEG. R)	TEMPERATURE (PSI)	STATIC	TOTAL	101/101	101/51A
1	.48	.68	-57.46	-67.44	505.82	483.29	16.625	16.474	1.5916	1.8668
2	.43	.65	-53.53	-66.48	505.74	487.40	16.794	14.768	1.5756	1.7729
3	.42	.64	-50.77	-65.76	505.44	488.42	16.834	14.932	1.5718	1.7721
4	.41	.65	-46.75	-64.45	505.75	489.68	16.923	15.069	1.5636	1.7559
5	.42	.67	-44.05	-63.41	504.66	489.59	16.921	14.994	1.5638	1.7647

EQUIVALENT INLET PRESSURE (PSI)

STREAM LINE	EQUIVALENT TEMPERATURE (DEG. R)	EQUIVALENT INLET PRESSURE (PSI)	EQUIV/STATIC PRESSURE RATIO
1	527.57	20.652	1.5
2	528.07	20.801	1.4
3	528.81	20.975	1.4
4	530.14	21.275	1.4
5	531.50	21.558	1.4



SET NUMBER	PAGE NUMBER	RPM	TOTAL/STATIC PRESSURE RATIO	INLET TOTAL PRESSURE (PSI)	INLET TOTAL TEMPERATURE (DEG. R)
1	3	10000.0	1.800	26.460	557.30

OVERALL TURBINE CHARACTERISTICS

STREAM LINE	PRESSURE RATIO TOT/STA	TOT/STA EFFICIENCY	TOT/TOT	HEAD COEFFICIENT	BLADE/JET SPEED RATIO	THEORETICAL DEGREE OF REACTION
1	1.8668	.5655	.7429	10.8039	.2306	.1102
2	1.7929	.6022	.7596	14.9821	.2584	.1576
3	1.7721	.6170	.7677	12.9877	.2775	.2250
4	1.7559	.6298	.7806	11.0959	.3002	.3105
.5	1.7647	.6306	.7877	10.0133	.3160	.3900

MASS AVERAGED QUANTITIES

HORSE POWER =	62.51 (HP)
MOMENT =	32.83 (FT-LB)
FLOW RATE =	3.54 (LB/SEC)
REFERRED RPM =	9644.68
REFERRED HORSE POWER =	33.50 (HP)
REFERRED MOMENT =	18.24 (FT-LB)
REFERRED FLOW RATE =	2.04 (LB/SEC)

TOTAL/STATIC EFFICIENCY =	.6118
TOTAL/TOTAL EFFICIENCY =	.7603
TOTAL/STATIC PRESSURE RATIO =	1.7922

HEAD COEFFICIENT =	13.3685
BLADE/JET SPEED RATIO =	.2795
THEORETICAL DEGREE OF REACTION =	.2358
MACH NUMBER AT STATION 0 =	1.2036



SET PAGE RPM TOTAL/STATIC INLET TOTAL INLET TOTAL  
 NUMBER NUMBER 15000.0 PRESSURE RATIO PRESSURE TEMPERATURE  
 1 1.800 26.460 557.30

STATOR EXIT SOLUTION

STREAM LINE	RADIAL POSITION (IN)	X=R/RH	RADIAL SHIFT (IN)	BLADE OPENING (IN)	Y=VA /VAM	EFFICIENCY	BLADE COEFFICIENT	LOSS	CONTINUITY	ZETA*	FLOW RATE FRACTION
1	2.764	.865	0.0000	.2126	1.0986	.9007	.0993	.0993	.0993	.0993	0.0000
2	3.003	.940	0.0000	.2347	1.0456	.8995	.1005	.1005	.1005	.1005	.2550
3	3.195	1.000	0.0000	.2526	1.0000	.8986	.1014	.1014	.1014	.1014	.4750
4	3.432	1.074	0.0000	.2745	.9945	.8984	.1016	.1016	.1016	.1016	.7582
5	3.627	1.135	0.0000	.2926	.8929	.8982	.1018	.1018	.1018	.1018	1.0000

RELATIVE VELOCITY (FPS)

STREAM LINE	AXIAL COMPONENT	RADIAL COMPONENT	TANGENTIAL COMPONENT	OVERALL VELOCITY	WHEEL VELOCITY
1	367.32	-14.73	811.42	890.81	361.81
2	349.62	3.32	763.74	839.96	393.10
3	338.52	7.65	723.92	797.44	456.29
4	314.81	27.34	676.15	746.32	418.50
5	298.55	35.42	636.97	704.35	474.77

TEMPERATURE (DEG. R)

STREAM LINE	MACH NUMBER	ABSOLUTE	RELATIVE	TOTAL	STATIC	TOTAL	STATIC	TOI/TOT	TOI/STI
1	.82	65.65	50.76	557.30	491.27	25.113	16.151	1.0536	1.6383
2	.72	63.21	46.68	527.30	498.59	28.700	17.111	1.0474	1.5464
3	.67	62.04	42.08	527.30	504.59	25.710	17.900	1.0426	1.4782
4	.63	61.89	35.79	557.30	510.95	25.352	18.834	1.0367	1.4049
5	.63	64.89	28.52	557.30	516.02	25.280	19.578	1.0324	1.3515





SET NUMBER	PAGE NUMBER	RPM	INLET/STATIC PRESSURE RATIO	INLET TOTAL PRESSURE (PSI)	INLET TOTAL TEMPERATURE (DEG. R)
1	2	15000.0	1.800	26.460	557.30

ROTOR EXIT SOLUTION

STREAM LINE	POSITION	X=R/RM	SHFT	RADIAL OPENING	BLADE	Y=VA	WAM	EFFICIENCY	LOSS	CONTINITY	FRACTION RATE
1	2.693	.825		.0710	.1912	.9852		.8597		.1404	0.0000
2	3.020	.975		-.0449	.2319	.6074		.6666		.1334	-.2304
3	3.265	1.000		-.0405	.2317	1.0000		.8719		.1282	-.4264
4	3.595	1.029		-.0337	.2287	1.0020		.8737		.1216	.17217
5	3.857	1.175		-.2130	.2983	1.2063		.8039		.1162	1.0000

RELATIVE VELOCITY (FPS)

STREAM LINE	AXIAL COMPONENT	RADIAL COMPONENT	TANGENTIAL COMPONENT	OVERALL VELOCITY	AXIAL COMPONENT	RADIAL COMPONENT	TANGENTIAL COMPONENT	OVERALL VELOCITY	WHEEL VELOCITY
1	275.35	-11.05	-310.15	414.89	275.36	-11.05	-662.66	717.68	352.51
2	263.00	2.52	-212.98	339.84	264.80	2.52	-608.29	663.43	395.31
3	279.51	6.40	-193.25	339.87	279.51	6.40	-608.74	680.74	427.39
4	308.03	26.75	-174.77	355.17	308.03	26.75	-644.10	714.47	469.33
5	337.17	40.00	-171.32	380.31	337.17	40.00	-673.59	754.32	502.26

MACH NUMBER FLOW ANGLE (DEG)

STREAM LINE	ABSOLUTE	RELATIVE	ABSOLUTE	RELATIVE	TEMPERATURE (DEG. R)	PRESSURE (PSI)	TOT/10T	TOT/STA
1	.39	.67	-48.40	-67.44	490.25	475.92	13.723	1.7381
2	.32	.62	-38.81	-66.48	493.32	483.71	15.823	1.6722
3	.32	.63	-34.66	-65.76	493.16	483.78	14.843	1.7826
4	.33	.66	-29.57	-64.45	493.10	487.61	15.932	1.7907
5	.35	.70	-26.93	-63.41	493.65	480.62	14.506	1.6637

EQUIVALENT INLET PRESSURE (PSI)

STREAM LINE	EQUIVALENT INLET PRESSURE (PSI)	EQUIVALENT PRESSURE RATIO
1	518.78	1.9
2	520.34	1.9
3	523.34	1.9
4	525.08	1.9
5	527.96	1.5



SET NUMBER	PAGE NUMBER	RPM	TOTAL/STATIC PRESSURE RATIO	INLET TOTAL PRESSURE (PSI)	INLET TOTAL TEMPERATURE (DEG. R)
1	3	15000.0	1.800	26.460	557.30

OVERALL TURBINE CHARACTERISTICS

STREAM LINE	PRESSURE RATIO TOT/STA	EFFICIENCY TOT/10T	HEAD COEFFICIENT	SLADE/JET SPEED RATIO	THEORETICAL DEGREE OF REACTION
1	1.281	.7035	8.7505	.3381	.2309
2	1.2914	.7482	6.6497	.3878	.2367
3	1.2826	.7560	5.8274	.4142	.3059
4	1.2907	.7513	5.0891	.4433	.3963
5	1.8141	.7414	4.6491	.4638	.4730

MASS AVERAGED QUANTITIES

HORSE POWER =	76.87 (HP)
MOMENT =	26.91 (FT-LB)
FLOW RATE =	3.51 (LB/SEC)
REFERRED RPM =	14467.03
REFERRED HORSE POWER =	41.19 (HP)
REFERRED MOMENT =	14.95 (FT-LB)
REFERRED FLOW RATE =	2.02 (LB/SEC)

TOTAL/STATIC EFFICIENCY =	.7445
TOTAL/TOTAL EFFICIENCY =	.8455
TOTAL/STATIC PRESSURE RATIO =	1.8090
TOTAL/TOTAL PRESSURE RATIO =	1.6751

HEAD COEFFICIENT =	6.0665
SLADE/JET SPEED RATIO =	.4060
THEORETICAL DEGREE OF REACTION =	.3227
MACH NUMBER AT STATION 0 =	.2014



SFT NUMBER PAGE NUMBER RPM TOTAL/STATIC PRESSURE RATIO INLET TOTAL PRESSURE INLET TOTAL TEMPERATURE  
 1 1 20000.0 3.000 267.460 557.30

STATOR EXIT SOLUTION

STREAM LINE	RADIAL POSITION (IN)	X=R/RM	SHFT (IN)	RADIAL OPENING (IN)	BLADE EFFICIENCY	Y=VA /VM	LOSS COEFFICIENT	CONTINUITY	Z/LIA*	FLOW RATE FRACTION
1	2.764	0.65	0.0000	2.126	0.049	1.0996	0.052	0.952	0.952	0.0000
2	3.003	0.940	0.0000	2.167	0.034	1.0443	0.062	0.946	0.946	0.2565
3	3.192	1.000	0.0000	2.276	0.023	1.0000	0.077	0.977	0.977	0.2565
4	3.432	1.074	0.0000	2.765	0.012	0.9408	0.088	0.908	0.908	0.7576
5	3.627	1.135	0.0000	2.926	0.002	0.8916	0.098	0.898	0.898	1.0000

ABSOLUTE VELOCITY (FPS)

RELATIVE VELOCITY (FPS)

STREAM LINE	AXIAL COMPONENT	RADIAL COMPONENT	TANGENTIAL COMPONENT	OVERALL VELOCITY	AXIAL COMPONENT	RADIAL COMPONENT	TANGENTIAL COMPONENT	OVERALL VELOCITY	WHEEL VELOCITY
1	352.31	-14.13	778.26	854.40	352.31	-14.13	295.65	460.27	460.41
2	335.13	3.18	732.20	805.27	335.18	3.18	208.06	394.51	523.14
3	329.48	7.33	693.70	764.16	329.40	7.33	135.98	356.51	557.72
4	301.44	26.18	647.42	714.64	301.44	26.18	49.49	308.44	598.94
5	285.67	33.89	607.50	673.98	285.67	33.89	-23.53	288.64	533.03

MACH NUMBER

FLOW ANGLE (DEG, R)

TEMPERATURE (DEG, R)

PRESSURE RATIO

STREAM LINE	ABSOLUTE	RELATIVE	ABSOLUTE	RELATIVE	TOTAL	STATIC	TOTAL	STATIC	TOT/TOT	TOT/STA
1	.78	.42	65.65	40.02	557.30	496.56	25.287	16.684	1.0364	1.5672
2	.73	.36	65.41	31.83	557.30	503.24	25.414	17.794	1.0332	1.4070
3	.69	.32	65.21	22.43	557.30	508.71	25.515	18.541	1.0370	1.4271
4	.64	.28	65.04	9.14	557.30	514.00	25.631	19.418	1.0383	1.4527
5	.60	.26	64.89	-4.71	557.30	519.50	25.721	20.115	1.0387	1.4754



SEI PAGE KPM INLET/STATIC INLET TOTAL INLET TOTAL  
 NUMBER NUMBER PRESSURE RATIO PRESSURE (PSI) TEMPERATURE (DEG. R) TEMPERATURE (DEG. R)

1 2 20000.0 1.800 26.460 557.30

KOTON EXJT SOLUTION

STREAM LINE	RADIAL POSITION	X=R/RM	SHRPT	RADIAL OPENING	FLADE	Y=VA	W/AM	EFFICENCY	BLADE	COEFFICIENT	LOSS	CONTINUITY	Z/100	FLOW RATE
1	3.693	.825	.0740	.1912	.9237	.8064	.1131	.1131	.1131	.1131	.1131	.1131	.1131	0.0000
2	3.020	.925	-.0418	.2418	.7145	.8915	.1085	.1085	.1085	.1085	.1085	.1085	.1085	.2243
3	2.265	1.000	-.0507	.2507	1.0000	.8950	.1050	.1050	.1050	.1050	.1050	.1050	.1050	.4169
4	1.595	1.098	-.0537	.2537	1.3684	.8861	.1140	.1140	.1140	.1140	.1140	.1140	.1140	.7142
5	1.037	1.175	-.02100	.2983	1.2382	.8790	.1210	.1210	.1210	.1210	.1210	.1210	.1210	1.0000

ABSOLUTE VELOCITY (FPS)

RELATIVE VELOCITY (FPS)

STREAM LINE	AXIAL COMPONENT	RADIAL COMPONENT	TANGENTIAL COMPONENT	OVERALL VELOCITY	AXIAL COMPONENT	RADIAL COMPONENT	TANGENTIAL COMPONENT	OVERALL VELOCITY	WHEEL VELOCITY
1	268.07	-10.75	-175.09	320.36	268.07	-10.75	-645.11	698.67	470.02
2	246.71	2.34	-39.64	249.88	246.71	2.34	-566.72	518.09	527.07
3	309.25	2.17	-29.15	311.40	309.26	6.17	-599.90	559.97	568.85
4	347.51	28.86	-20.91	349.26	347.51	26.86	-646.88	679.33	708.99
5		41.23	-24.56	350.81		41.23	-694.24	777.45	669.68

MACH NUMBER

FLOW ANGLE (DEG)

TEMPERATURE (DEG. R)

PRESSURE RATIO

STREAM LINE	ABSOLUTE	RELATIVE	ABSOLUTE	RELATIVE	TOTAL	STATIC	TOTAL	STATIC	TOT/TOT	TOT/STA
1					461.12	472.56	14.545	13.661	1.8191	1.9370
2	.30		-35.15		489.95	484.76	15.744	15.168	1.6305	1.7445
3	.25		-6.17		490.59	482.53	15.789	14.162	1.6759	1.7451
4	.29		-2.87		490.59	482.53	15.759	14.971	1.6791	1.7772
5	.33		-4.04		490.35	480.11	15.619	14.507	1.6940	1.8239

EQUIV/STATIC PRESSURE RATIO

FOOTVALENT INLET PRESSURE (PSI)

EQUIV/STATIC PRESSURE RATIO

1 2 3 4 5

1	513.20	1.4	18.949	1.4
2	516.55	1.3	19.483	1.3
3	520.42	1.3	20.079	1.3
4	525.35	1.4	20.846	1.4
5	530.41	1.5	21.632	1.5





SET NUMBER	PAGE NUMBER	KPM	TOTAL/STATIC PRESSURE RATIO	INLET TOTAL PRESSURE (PSI)	INLET TOTAL TEMPERATURE (DEG. R)
1	3	20000.0	1.800	26.460	557.30

OVERALL TURBINE CHARACTERISTICS

STREAM LINE	PRESSURE RATIO TOT/STA	EFFICIENCY TOT/TOT	HEAD COEFFICIENT	BLADE/JET SPEED RATIO	THEORETICAL DEGREE OF REACTION
1	1.9338	.7943	4.9528	.4493	.3000
2	1.7445	.8221	3.5835	.5283	.2709
3	1.7351	.8193	3.1668	.5619	.3430
4	1.7792	.7887	2.8337	.5940	.4425
5	1.8239	.8593	2.6368	.6158	.5225

MASS AVERAGED QUANTITIES

HORSE POWER =	81.09 (HP)
TORQUE =	21.30 (FT-LB)
FLOW RATE =	3.51 (LB/SEC)
REFERRED RPM =	19289.77
REFERRED HORSE POWER =	43.45 (HP)
REFERRED TORQUE =	11.83 (FT-LB)
REFERRED FLOW RATE =	2.02 (LB/SEC)

TOTAL/STATIC EFFICIENCY =	.8020
TOTAL/TOTAL EFFICIENCY =	.8724
TOTAL/STATIC PRESSURE RATIO =	1.7873
TOTAL/TOTAL PRESSURE RATIO =	1.6980

HEAD COEFFICIENT RATIO =	3.7447
BLADE/JET SPEED =	.5486
THEORETICAL DEGREE OF REACTION =	.3669
MACH NUMBER AT STATION 0 =	.2015



SET PAGE RPM TOTAL/STATIC INLET TOTAL INLET TOTAL  
 NUMBER NUMBER 25000.0 PRESSURE RATIO PRESSURE TEMPERATURE  
 1 1.600 26.460 557.30

STATOR EXIT SOLUTION

STREAM LINE	RADIAL POSITION (IN)	X=R/RM	RADIAL SWIFT (IN)	BLADE OPENING (IN)	Y=VA /VAM	EFFICIENCY	BLADE COEFFICIENT	LOSS	CONTINUITY	ZETA*	FLOW RATE FRACTION
1	2.764	.865	0.0000	.2126	1.1008	.9085	.0915	.0915	.0915	.0915	0.0000
2	3.093	.940	0.0000	.2347	1.0466	.9094	.0936	.0936	.0936	.0936	.2567
3	3.175	1.000	0.0290	.2526	1.0000	.9047	.0953	.0953	.0953	.0953	.4772
4	3.432	1.074	0.0000	.2745	.9404	.9032	.0968	.0968	.0968	.0968	.7598
5	3.627	1.135	0.0000	.2926	.8909	.9019	.0981	.0981	.0981	.0981	1.0000

RELATIVE VELOCITY (FPS)

STREAM LINE	AXIAL COMPONENT	RADIAL COMPONENT	TANGENTIAL COMPONENT	OVERALL VELOCITY	AXIAL COMPONENT	RADIAL COMPONENT	TANGENTIAL COMPONENT	OVERALL VELOCITY	WHEEL VELOCITY
1	353.56	-14.18	781.02	857.44	353.56	-14.18	178.01	396.09	603.01
2	336.16	3.19	734.34	807.63	336.16	3.19	79.17	345.37	655.17
3	330.62	7.35	695.41	766.04	330.62	7.35	-1.74	330.71	697.15
4	302.05	26.23	648.72	716.07	302.05	26.23	-99.95	319.24	748.67
5	286.15	33.95	610.53	675.11	286.15	33.95	-180.77	340.17	791.29

TEMPERATURE (DEG. R)

STREAM LINE	ABSOLUTE	RELATIVE	AXIAL COMPONENT	RADIAL COMPONENT	TANGENTIAL COMPONENT	OVERALL VELOCITY	WHEEL VELOCITY	TEMPERATURE (DEG. R)	PRESSURE RATIO
1	79	36	557.30	496.12	25.328	16.860	1.0447	1.5694	
2	73	31	557.30	503.02	25.431	16.725	1.0300	1.4883	
3	69	30	557.30	508.49	25.535	16.735	1.0369	1.4263	
4	64	29	557.30	514.63	25.646	18.406	1.0317	1.3635	
5	60	30	557.30	519.37	25.732	20.106	1.0283	1.3160	



SET NUMBER	ROTOR NUMBER	RPM	EQUIV/STATIC PRESSURE RATIO	INLET TOTAL PRESSURE (PSI)	INLET TOTAL TEMPERATURE (DEG. R)
1	2	25000.0	1.800	26.460	557.30

ROTOR EXIT SOLUTION

STREAM LINE	RADIAL POSITION	X=R/RM	SHIFT	RADIAL OPENING	BLADE	Y=VA /VAM	EFFICIENCY	LOSS COEFFICIENT	CONTINUITY	FRACTION RATE
1	2.693	.825	-.0710	.1912	.1912	1.0024	.9035	.0966	.0966	0.0000
2	3.020	1.925	-.0168	.2218	.2218	.8851	.8858	.1143	.1143	.2176
3	3.265	1.000	-.0405	.2447	.2447	1.0000	.8795	.1275	.1275	.4048
4	3.585	1.098	-.1537	.2747	.2747	1.1867	.8819	.1181	.1181	.7035
5	3.837	1.175	-.2100	.2983	.2983	1.3613	.8893	.1108	.1108	1.0000

ABSOLUTE VELOCITY (FPS)

STREAM LINE	AXIAL COMPONENT	RADIAL COMPONENT	TANGENTIAL COMPONENT	OVERALL VELOCITY	AXIAL COMPONENT	RADIAL COMPONENT	TANGENTIAL COMPONENT	OVERALL VELOCITY	WHEEL VELOCITY
1	269.51	-10.81	-61.06	276.55	269.51	-10.81	-648.58	702.43	587.52
2	237.98	2.26	112.18	253.10	237.98	2.26	-548.66	596.32	458.84
3	268.87	6.15	115.30	292.61	268.87	6.15	-592.81	654.79	713.31
4	319.06	27.71	115.04	340.30	319.06	27.71	-667.17	740.06	783.21
5	366.00	43.42	105.92	383.48	366.00	43.42	-733.19	818.83	857.11

MACH NUMBER

STREAM LINE	FLOW ANGLE (DEG)			TEMPERATURE (DEG. R)		PRESSURE (PSI)		101/101	101/51A
	ABSOLUTE	RELATIVE	RELATIVE	TOTAL	STATIC	TOTAL	STATIC		
1	.26	-12.77	-67.44	473.95	466.59	13.797	13.158	1.9128	2.0110
2	.24	-25.24	-66.48	489.53	481.77	13.720	15.092	1.6832	1.7544
3	.27	21.21	-65.76	490.29	483.67	13.701	14.972	1.6853	1.7673
4	.32	19.83	-64.45	491.45	486.81	13.794	14.736	1.6753	1.7956
5	.36	16.14	-63.41	491.66	479.42	13.768	14.436	1.6781	1.8329

EQUIVALENT INLET PRESSURE (PSI)

STREAM LINE	EQUIVALENT INLET PRESSURE (PSI)	EQUIV/STATIC PRESSURE RATIO
1	207.64	1.4
2	313.95	1.3
3	379.50	1.3
4	21.142	1.4
5	22.335	1.5



SET NUMBER	PAGE NUMBER	KPM	TOTAL/STATIC PRESSURE RATIO	INLET TOTAL PRESSURE (PSI)	INLET TOTAL TEMPERATURE (DEG. R)
1	3	25000.0	1.800	26.460	557.30

OVERALL TURBINE CHARACTERISTICS

STREAM LINE	PRESSURE RATIO TOT/STA	EFFICIENCY TOT/TOT	HEAD COEFFICIENT	BLADE/JET SPEED RATIO	THEORETICAL DEGREE OF REACTION
1	2.0110	.8365	3.3326	.5478	.3322
2	1.7574	.8797	2.3150	.6572	.2758
3	1.7673	.8683	2.0690	.6952	.3550
4	1.7756	.8623	1.8400	.7372	.4495
5	1.8329	.8568	1.7001	.7669	.5253

MASS AVERAGED QUANTITIES

HORSE POWER =	81.93 (HP)
MOMENT =	17.21 (FT-LB)
FLOW RATE =	3.52 (LB/SEC)
REFERRED RPM =	2411.71
REFERRED HORSE POWER =	43.90 (HP)
REFERRED MOMENT =	9.56 (FT-LB)
REFERRED FLOW RATE =	2.03 (LB/SEC)

TOTAL/STATIC EFFICIENCY =	.7941
TOTAL/TOTAL EFFICIENCY =	.8710
TOTAL/STATIC PRESSURE RATIO =	1.8098
TOTAL/TOTAL PRESSURE RATIO =	1.9105

HEAD COEFFICIENT =	2.1851
BLADE/JET SPEED RATIO =	.6765
THEORETICAL DEGREE OF REACTION =	.3773
MACH NUMBER AT STATION 0 =	.2022





SET PACE TOTAL/STATIC INLET TOTAL INLET TOTAL  
 NUMBER NUMBER RPM PRESSURE RATIO PRESSURE TEMPERATURE  
 1 1 30000.0 1.800 26.460 557.30

STATOR EXIT SOLUTION

STREAM LINE	RADIAL POSITION (IN)	X=R/RM	RADIAL SHIFT (IN)	BLADE OPENING (IN)	Y=VA /VAM	BLADE EFFICIENCY	LOSS COEFFICIENT	ZETA*	CONTINUITY	FLOW RATE FRACTION
1	2.764	.865	0.0000	.2126	1.1018	.9124	.0876	.0076	0.0000	
2	3.092	.840	0.0000	.2397	1.0470	.9096	.0904	.0904	.2562	
3	3.432	1.070	0.0000	.2556	1.0000	.9073	.0927	.0927	.4766	
4	3.627	1.074	0.0000	.2745	1.0400	.9055	.0945	.0945	.7593	
5		1.135	0.0000	.2926	.8903	.9039	.0961	.0961	1.0000	

ABSOLUTE VELOCITY (FPS)      RELATIVE VELOCITY (FPS)

STREAM LINE	AXIAL COMPONENT	RADIAL COMPONENT	TANGENTIAL COMPONENT	OVERALL VELOCITY	AXIAL COMPONENT	RADIAL COMPONENT	TANGENTIAL COMPONENT	OVERALL VELOCITY	WHEEL VELOCITY
1	362.67	-14.55	801.15	879.53	362.67	-14.55	77.53	371.15	723.62
2	344.62	3.27	752.84	827.97	344.62	3.27	-33.37	346.25	786.21
3	335.37	7.53	712.63	785.01	335.37	7.53	-123.95	357.63	836.58
4	309.41	26.87	664.52	733.51	309.41	26.87	-233.89	368.79	898.41
5	293.04	34.77	625.22	691.36	293.04	34.77	-324.33	438.49	949.55

MACH NUMBER      FLOW ANGLE (DEG)      TEMPERATURE (DEG. R)      PRESSURE (PSI)      PRESSURE RATIO

STREAM LINE	ABSOLUTE	RELATIVE	ABSOLUTE	RELATIVE	TOTAL	STATIC	TOTAL	STATIC	101/10T	101/STA
1	.81	.34	65.65	12.07	557.30	492.93	25.317	16.476	1.0452	1.6660
2	.76	.32	65.41	-20.53	557.30	500.26	25.625	17.423	1.0407	1.5187
3	.71	.32	65.21	-37.29	557.30	506.03	25.574	16.300	1.0371	1.4559
4	.66	.35	65.04	-37.09	557.30	512.53	25.625	19.115	1.0326	1.3843
5	.62	.39	64.89	-47.90	557.30	517.53	25.711	19.841	1.0291	1.3336



SET NUMBER PAGE RPM TOTAL/STATIC PRESSURE TOTAL INLET TEMPERATURE TOTAL  
 NUMBER NUMBER (PSI) (DEG. R)

1 2 30000.0 1.800 26.460 557.30

MOTOR EXIT SOLUTION

STREAM LINE	RADIAL POSITION	X=R/RM	SHOULDER	BLADE	Y=VA /VAM	EFFICIENCY	LOSS COEFFICIENT	CONTINITY	FRACTION RATE
1	2.693	.825	.0710	.1912	1.0116	.9130	.0070	.0870	0.0000
2	3.020	.875	-.0169	.2218	.8541	.8930	.1070	.1070	.2084
3	3.285	1.000	-.0405	.2447	1.0000	.8780	.1221	.1221	.3899
4	3.595	1.098	-.1537	.2747	1.2331	.8875	.1125	.1125	.6913
5	3.837	1.175	-.2100	.2983	1.4460	.8950	.1051	.1051	1.0000

ABSOLUTE VELOCITY (FPS) RELATIVE VELOCITY (FPS)

STREAM LINE	AXIAL COMPONENT	RADIAL COMPONENT	TANGENTIAL COMPONENT	OVERALL VELOCITY	AXIAL COMPONENT	RADIAL COMPONENT	TANGENTIAL COMPONENT	OVERALL VELOCITY	WHEEL VELOCITY
1	265.45	-10.65	66.22	273.79	265.45	-10.65	-638.84	691.85	705.03
2	224.13	2.13	275.76	355.36	224.13	2.13	-514.84	561.52	790.61
3	262.40	6.00	272.12	378.07	262.40	6.00	-582.66	639.05	854.78
4	323.58	28.10	262.04	417.32	323.58	28.10	-676.61	750.53	1004.53
5	379.44	45.02	246.49	454.71	379.44	45.02	-758.03	848.89	

MACH NUMBER FLOW ANGLE (DEG.) TEMPERATURE (DEG. R)

STREAM LINE	ABSOLUTE	RELATIVE	ABSOLUTE	RELATIVE	TOTAL	STATIC	TOTAL	STATIC	TOT/10T	TOT/STA
1	.26	.66	14.01	-67.44	468.59	462.35	13.407	12.793	1.9736	2.0683
2	.33	.59	50.90	-66.48	495.09	484.57	16.422	15.214	1.6113	1.7039
3	.39	.70	46.05	-65.76	496.79	485.34	16.490	15.189	1.6087	1.7424
4	.42	.79	39.00	-64.45	498.88	484.59	16.656	15.039	1.6825	1.7633
5			33.01	-63.41	499.71	482.50	16.671	14.747	1.5872	1.7942

STREAM LINE EQUIVALENT EQUIVALENT EQUIV/STATIC

STREAM LINE	EQUIVALENT TEMPERATURE (DEG. R)	EQUIVALENT INLET PRESSURE (PSI)	EQUIVALENT PRESSURE RATIO
1	502.18	17.584	1.4
2	510.61	18.744	1.2
3	519.23	19.927	1.3
4	527.53	21.126	1.4
5	542.48	23.594	1.6



SET NUMBER 1  
 PAGE NUMBER 3  
 RPM 3000.0  
 TOTAL/STATIC PRESSURE RATIO 1.800  
 INLET TOTAL PRESSURE (PSI) 26.460  
 INLET TOTAL TEMPERATURE (DEG. R) 557.30

OVERALL TURBINE CHARACTERISTICS

STREAM LINE	PRESSURE RATIO TOT/STG	EFFICIENCY TOT/TOT	HEAD COEFFICIENT	BLADE/JET SPEED RATIO	INEFFECTIVE DEGREE OF REACTION
1	2.0683	1.9736	2.3984	.657	.3248
2	1.7369	1.6113	1.5811	.7953	.5288
3	1.7424	1.6047	1.4017	.8440	.3697
4	1.7613	1.5886	1.2390	.8984	.4050
5	1.7942	1.5872	1.1425	.9350	.4067

MASS AVERAGED QUANTITIES

HORSE POWER = 75.08 (HP)  
 MOMENT = 13.14 (FT-LB)  
 FLOW RATE = 3.53 (LB/SEC)

REFERRED RPM = 28934.05  
 REFERRED HORSE POWER = 40.24 (HP)  
 REFERRED MOMENT = 7.30 (FT-LB)  
 REFERRED FLOW RATE = 2.03 (LB/SEC)

TOTAL/STATIC EFFICIENCY = .7419  
 TOTAL/TOTAL EFFICIENCY = .8626  
 TOTAL/STATIC PRESSURE RATIO = 1.7930  
 TOTAL/TOTAL PRESSURE RATIO = 1.6462

HEAD COEFFICIENT = 1.4986  
 BLADE/JET SPEED RATIO = .8169  
 THEORETICAL DEGREE OF REACTION = .3373  
 MACH NUMBER AT STATION 0 = .2025



SET NUMBER 1 CASE NUMBER 1 RPM 5000.0  
 TOTAL/STATIC PRESSURE RATIO 2.000  
 INLET TOTAL TEMPERATURE 591.01  
 PRESSURE 29.400

STATOR EXIT SOLUTION

STREAM LINE	RADIAL POSITION (IN)	X=R/RM	RADIAL SHIFT (IN)	BLADE OPENING (IN)	BLADE EFFICIENCY	Y=VA /VAM	LOSS COEFFICIENT	ZETA*	CONTINUITY	FLOW RATE FRACTION
1	3.764	.865	0.0000	.2126	.8731	1.1063	.0769	.0769	0.0000	
2	3.003	.840	0.0000	.2347	.9158	1.0488	.0842	.0842	.2493	
3	3.135	1.000	0.0290	.2526	.9100	1.0000	.0900	.0900	.4668	
4	3.452	1.074	0.0000	.2745	.9046	.9385	.0954	.0954	.7518	
5	3.627	1.135	0.0000	.2926	.9001	.8879	.0999	.0999	1.0000	

RELATIVE VELOCITY (FPS)

STREAM LINE	AXIAL COMPONENT	RADIAL COMPONENT	TANGENTIAL COMPONENT	OVERALL VELOCITY	AXIAL COMPONENT	RADIAL COMPONENT	TANGENTIAL COMPONENT	OVERALL VELOCITY	WHEEL VELOCITY
1	488.05	-19.58	1078.13	1183.62	488.05	-19.58	957.53	1074.92	120.60
2	462.68	4.40	1010.73	1111.61	462.68	4.40	879.70	993.96	131.03
3	447.96	10.09	955.11	1052.11	447.96	10.09	815.68	930.65	139.43
4	414.01	35.96	889.19	981.51	414.01	35.96	739.46	848.23	149.73
5	391.68	46.47	835.68	924.08	391.68	46.47	677.42	783.88	158.26

FLOW ANGLE (DEG)

STREAM LINE	ABSOLUTE	RELATIVE	ABSOLUTE	RELATIVE	TOTAL	STATIC	TOTAL	STATIC	TOT/TOT	TOT/STIA
1	1.11	1.01	65.65	63.00	591.01	474.43	27.346	13.674	1.0751	2.3197
2	1.03	.85	65.41	62.26	591.01	488.99	27.454	14.064	1.0708	2.0805
3	.96	.77	65.21	61.23	591.01	498.90	27.564	15.294	1.0676	1.9259
4	.89	.70	65.04	60.76	591.01	510.85	27.732	16.600	1.0641	1.7658
5	.83	.70	64.89	59.97	591.01	519.95	27.669	17.800	1.0549	1.6517

TEMPERATURE (DEG. R)

STREAM LINE	ABSOLUTE	RELATIVE	ABSOLUTE	RELATIVE	TOTAL	STATIC	TOTAL	STATIC	PRESSURE RATIO
1	1.11	1.01	65.65	63.00	591.01	474.43	27.346	13.674	1.0751
2	1.03	.85	65.41	62.26	591.01	488.99	27.454	14.064	1.0708
3	.96	.77	65.21	61.23	591.01	498.90	27.564	15.294	1.0676
4	.89	.70	65.04	60.76	591.01	510.85	27.732	16.600	1.0641
5	.83	.70	64.89	59.97	591.01	519.95	27.669	17.800	1.0549





SET NUMBER CASE NUMBER RPM PRESSURE RATIO PRESSURE TOTAL TEMPERATURE TOTAL  
 (DEG. R)  
 1 2 5000.0 2.000 29.400 591.01

ROTOR EXIT SOLUTION

STREAM LINE	RADIAL POSITION	X=R/RM	RADIAL OPENING	BLADE	Y=VA /VAM	EFFICIENCY	LOSS COEFFICIENT	CONTINUITY	FRACTION RATE
1	3.697	.925	.0710	.1912	.9713	.7753	.2248	.2248	0.0000
2	3.229	.925	-.0169	.2219	1.0055	.7718	.2282	.2282	.2393
3	3.582	1.000	-.0435	.2747	1.0000	.7652	.2308	.2308	.4424
4	3.837	1.000	-.0537	.2747	1.0174	.7655	.2345	.2345	.7357
5	3.837	1.175	-.2100	.2983	1.0538	.7627	.2374	.2374	1.0000

ABSOLUTE VELOCITY (FPS)

STREAM LINE	AXIAL COMPONENT	RADIAL COMPONENT	TANGENTIAL COMPONENT	OVERALL VELOCITY	AXIAL COMPONENT	RADIAL COMPONENT	TANGENTIAL COMPONENT	OVERALL VELOCITY	WHEEL VELOCITY
1	336.20	-13.49	-691.57	769.08	336.20	-13.49	-609.08	876.25	117.50
2	348.06	3.31	-667.76	753.03	340.06	3.31	-799.53	872.01	131.77
3	346.15	7.92	-626.16	715.52	346.15	7.92	-768.84	843.01	142.44
4	352.86	30.65	-581.39	680.78	352.86	30.65	-737.84	818.44	156.44
5	364.76	43.28	-561.29	670.80	364.76	43.28	-728.71	816.06	167.42

MACH NUMBER FLOW ANGLE (DEG)

STREAM LINE	ABSOLUTE	RELATIVE	ABSOLUTE	RELATIVE	TOTAL	STATIC	TOTAL	STATIC	TOT/TOT	TEMPERATURE (DEG. R)	PRESSURE RATIO
1	.70	.79	-64.08	-67.44	555.05	506.63	19.365	13.999	1.5182	2.1002	2.0869
2	.68	.79	-62.47	-66.48	554.33	507.14	19.235	14.088	1.5285	1.9955	1.9955
3	.65	.76	-61.07	-65.76	554.00	511.90	19.427	14.733	1.5133	1.9986	1.9986
4	.61	.74	-58.75	-64.45	553.71	515.15	19.619	15.238	1.4986	1.9119	1.9119
5	.60	.73	-56.99	-63.41	553.36	515.92	19.651	15.577	1.4961		

EQUIVALENT EQUIVALENT INLET PRESSURE (PSI) RATIO

STREAM LINE	EQUIVALENT TEMPERATURE (DEG. R)	EQUIVALENT INLET PRESSURE (PSI)	RATIO
1	570.52	24.169	1.7
2	570.41	24.250	1.7
3	571.04	24.440	1.7
4	570.89	24.566	1.6
5	571.33	24.754	1.6



SET NUMBER	PAGE NUMBER	RPM	TOTAL/STATIC PRESSURE RATIO	INLET TOTAL PRESSURE (PSI)	INLET TOTAL TEMPERATURE (DEG. R)
1	3	5000.0	2.000	29.400	591.01

OVERALL TURBINE CHARACTERISTICS

STREAM LINE	PRESSURE RATIO TOT/STA	TOT/STA	EFFICIENCY TOT/101	HEAD COEFFICIENT	BLADE/JET SPEED RATIO	THEORETICAL DEGREE OF REACTION
1	2.1002	.3115	.5291	93.2818	.1035	-.1186
2	1.8285	.3274	.5437	79.4110	.1229	-.0021
3	1.5133	.3496	.5410	65.4137	.1326	.0437
4	1.4086	.3686	.5782	47.2278	.1358	.2241
5	1.9119	.3769	.5859	47.9336	.1444	.2078

MASS AVERAGED QUANTITIES

HORSE POWER =	50.34	(HP)
MOMENT =	52.88	(FT-LB)
FLOW RATE =	4.02	(LB/SEC)
REFERRED RPM =	4682.79	(HP)
REFERRED HORSE POWER =	23.58	(FT-LB)
REFERRED MOMENT =	26.44	(LB/SEC)
REFERRED FLOW RATE =	2.15	
TOTAL/STATIC EFFICIENCY =	.3475	
TOTAL/TOTAL EFFICIENCY =	.5601	
TOTAL/STATIC PRESSURE RATIO =	2.0045	
TOTAL/TOTAL PRESSURE RATIO =	1.5119	
HEAD COEFFICIENT =	67.1736	
BLADE/JET SPEED RATIO =	.1229	
THEORETICAL DEGREE OF REACTION =	.0529	
MACH NUMBER AT STATION 0 =	.2146	



SET PAGE TOTAL/STATIC INLET TOTAL  
 NUMBER NUMBER RPM PRESSURE RATIO PRESSURE TEMPERATURE  
 1 1 10000.0 2.000 29.400 591.01

STATOR EXIT SOLUTION

STREAM LINE	RADIAL POSITION (IN)	X=R/RM	RADIAL SHIFT (IN)	BLADE OPENING (IN)	BLADE EFFICIENCY	LOSS COEFFICIENT	Z/LTA* CONTINUITY	FLUX RATE FRACTION
1	2.764	.865	0.0000	.2126	.9122	.0878	.0878	0.0000
2	3.003	.940	0.0000	.2347	.9056	.0944	.0944	.2519
3	3.125	1.000	0.0290	.2526	.9002	.0998	.0998	.4711
4	3.432	1.074	0.0000	.2745	.8957	.1043	.1043	.7554
5	3.627	1.135	0.0000	.2926	.8921	.1079	.1079	1.0000

STREAM LINE	ABSOLUTE VELOCITY (FPS)				RELATIVE VELOCITY (FPS)			
	AXIAL COMPONENT	RADIAL COMPONENT	TANGENTIAL COMPONENT	OVERALL VELOCITY	AXIAL COMPONENT	RADIAL COMPONENT	TANGENTIAL COMPONENT	OVERALL VELOCITY
1	430.56	-17.27	951.13	1044.19	430.56	-17.27	709.93	830.47
2	408.48	3.88	892.34	981.40	408.48	3.88	630.27	751.08
3	374.59	8.92	843.80	929.50	374.59	8.92	564.94	689.16
4	366.11	31.80	786.31	867.95	366.11	31.80	486.84	609.97
5	346.65	41.13	739.61	817.85	346.65	41.13	423.09	540.51

STREAM LINE	MACH NUMBER			TEMPERATURE (DEG. R)			PRESSURE (PSI)		
	ABSOLUTE	RELATIVE	FLOW ANGLE (DEG)	ABSOLUTE	RELATIVE	TEMPERATURE (DEG. R)	TOTAL	STATIC	PRESSURE RATIO
1	.95	.76	65.65	591.01	500.28	27.643	15.426	1.0616	1.9059
2	.89	.68	65.41	591.01	519.86	27.650	16.683	1.0539	1.7684
3	.83	.62	65.21	591.01	519.86	28.003	17.688	1.0459	1.6682
4	.77	.54	65.04	591.01	528.35	28.126	18.914	1.0459	1.5564
5	.72	.48	64.89	591.01	535.35	28.126	19.896	1.0453	1.4777



SET NUMBER PAGE RPM PRESSURE/STATIC PRESSURE INLET TOTAL INLET TOTAL  
 NUMBER NUMBER (DEG. R) (PSI) (DEG. R)

1 2 10000.0 2.000 29.400 591.01

ROTOR EXIT SOLUTION

STREAM LINE	RADIAL POSITION	X=R/RM	SH	RADIAL OPENING	BLADE	Y=VA /VAM	EFFICIENCY	HEADY	LOSS	CONTINUITY	FRACTION RATE
1	2.693	.825	.0710	.1912	.8273	.9767	.8273	.1727	.1727	.1727	0.0000
2	3.020	.925	-.0168	.2218	.8274	.9818	.8274	.1726	.1726	.1726	.2366
3	3.265	1.000	-.0405	.2447	.8275	1.0000	.8275	.1725	.1725	.1725	.4377
4	3.585	1.098	-.1537	.2747	.8282	1.0531	.8282	.1678	.1678	.1678	.7312
5	3.837	1.175	-.2100	.2983	.8359	1.1159	.8359	.1641	.1641	.1641	1.0000

ABSOLUTE VELOCITY (FPS)

STREAM LINE	AXIAL COMPONENT	RADIAL COMPONENT	TANGENTIAL COMPONENT	OVERALL VELOCITY	AXIAL COMPONENT	RADIAL COMPONENT	TANGENTIAL COMPONENT	OVERALL VELOCITY	WHEEL VELOCITY
1	325.69	-13.06	-548.77	638.28	325.69	-13.06	-548.77	638.28	235.01
2	327.40	3.11	-488.54	588.10	327.40	3.11	-488.54	588.10	263.94
3	333.47	7.63	-455.53	564.43	333.47	7.63	-455.53	564.43	312.68
4	351.18	30.50	-421.45	549.43	351.18	30.50	-421.45	549.43	354.84
5	372.11	44.15	-408.55	554.38	372.11	44.15	-408.55	554.38	

RELATIVE VELOCITY (FPS)

STREAM LINE	AXIAL COMPONENT	RADIAL COMPONENT	TANGENTIAL COMPONENT	OVERALL VELOCITY	AXIAL COMPONENT	RADIAL COMPONENT	TANGENTIAL COMPONENT	OVERALL VELOCITY
1	325.69	-13.06	-283.70	448.86	325.69	-13.06	-283.70	448.86
2	327.40	3.11	-223.07	423.95	327.40	3.11	-223.07	423.95
3	333.47	7.63	-210.43	412.51	333.47	7.63	-210.43	412.51
4	351.18	30.50	-214.33	432.58	351.18	30.50	-214.33	432.58
5	372.11	44.15	-243.40	452.50	372.11	44.15	-243.40	452.50

MACH NUMBER

STREAM LINE	ABSOLUTE	RELATIVE	EQUIV/STATIC PRESSURE	FLOW ANGLE (DEG)	TEMPERATURE (DEG. R)	TEMPERATURE (PSI)	STATIC	TOTAL	TOTAL/101	101/51A
1	.58	.78	-52.32	-62.44	531.37	497.47	13.831	17.424	1.6874	2.1053
2	.61	.74	-53.00	-65.76	530.66	501.80	14.421	17.529	1.6772	2.0848
3	.61	.74	-53.00	-65.76	530.25	504.04	14.722	17.580	1.6723	1.9970
4	.60	.74	-50.20	-64.45	529.88	504.76	14.911	17.674	1.6634	1.9717
5	.60	.76	-47.68	-63.41	529.28	503.71	14.846	17.655	1.6652	1.9804

EQUIVALENT TEMPERATURE (DEG. R)

STREAM LINE	EQUIVALENT TEMPERATURE (DEG. R)	EQUIV/STATIC PRESSURE
1	527.43	1.6
2	527.87	1.6
3	529.92	1.6
4	531.85	1.6
5	561.38	1.6





SET NUMBER	PAGE NUMBER	KPM	TOTAL/STATIC PRESSURE RATIO	INLET TOTAL PRESSURE (PSI)	INLET TOTAL TEMPERATURE (DEG. R)
1	3	10000.0	2.000	29.400	591.01

. OVERALL TURBINE CHARACTERISTICS

STREAM LINE	PRESSURE RATIO TOT/STA	EFFICIENCY TOT/ST	HEAD COEFFICIENT	BLADE/JET SPEED RATIO	THEORETICAL DEGREE OF REACTION
1	2.1253	.5208	23.6556	.2056	.1315
2	2.0386	.545	17.0412	.2282	.1867
3	1.9770	.5734	16.3763	.2471	.2463
4	1.9717	.5867	13.9628	.2676	.3284
5	1.9804	.5889	12.5727	.2820	.4047

MASS AVERAGED QUANTITIES

HORSE POWER =	83.03	(HP)
MOMENT FLOW RATE =	42.56	(FT-LB)
	3.93	(LB/SEC)
REFERRED RPM	9365.59	(HP)
REFERRED HORSE POWER =	37.95	(HP)
REFERRED MOMENT FLOW RATE =	21.28	(FT-LB)
REFERRED FLOW RATE =	2.10	(LB/SEC)

TOTAL/STATIC EFFICIENCY =	.5674
TOTAL/STATIC EFFICIENCY =	.7522
TOTAL/STATIC PRESSURE RATIO =	2.0150
TOTAL/STATIC PRESSURE RATIO =	1.6723

HEAD COEFFICIENT	=	16.0736
BLADE/JET SPEED RATIO	=	.2434
THEORETICAL DEGREE OF REACTION	=	.2574
MACH NUMBER AT STATION 0	=	.2093



SET PAGE RPM TOTAL/STATIC INLET TOTAL INLET TOTAL  
 NUMBER NUMBER 15000.0 PRESSURE RATIO PRESSURE TEMPERATURE TEMPERATURE  
 1 1 2.000 29.400 591.01

STATOR EXIT SOLUTION

STREAM LINE	RADIAL POSITION (IN)	X=R/RM	RADIAL SHIFT (IN)	RADIAL OPENING (IN)	BLADE OPENING	Y=VA /VAN	BLADE EFFICIENCY	LOSS COEFFICIENT	ZETA*	CONTINUITY	FLOW RATE FRACTION
1	2.764	.865	0.0000	.2126		1.1015	.9061	.0959	.0939		0.0000
2	3.003	.940	0.0000	.2347		1.0467	.9022	.0978	.0978		.2534
3	3.195	1.000	0.0290	.2526		1.0000	.8990	.1011	.1011		.4729
4	3.432	1.074	0.0000	.2745		1.9413	.8989	.1011	.1011		.7566
5	3.627	1.135	0.0000	.2926		.8928	.8988	.1011	.1011		1.0000

ABSOLUTE VELOCITY (FPS)

STREAM LINE	AXIAL COMPONENT	RADIAL COMPONENT	TANGENTIAL COMPONENT	OVERALL VELOCITY	AXIAL COMPONENT	RADIAL COMPONENT	TANGENTIAL COMPONENT	OVERALL VELOCITY	WHEEL VELOCITY
1	402.85	-16.16	889.91	976.98	402.85	-16.16	528.11	664.41	361.81
2	383.80	3.64	836.24	919.70	383.80	3.64	443.13	585.59	393.10
3	369.75	8.37	791.86	872.28	369.75	8.37	373.57	523.68	418.29
4	344.25	29.90	739.37	816.13	344.25	29.90	290.16	451.23	449.20
5	326.51	38.74	696.63	770.33	326.51	38.74	221.86	396.65	474.77

MACH NUMBER

STREAM LINE	FLOW ANGLE (DEG. R)			TEMPERATURE (DEG. R)			PRESSURE (PSI)		
	ABSOLUTE	RELATIVE	RELATIVE	TOTAL	STATIC	STATIC	TOTAL	STATIC	TOTAL
1	.88	.60	52.67	591.01	511.58	16.762	27.778	16.762	1.0584
2	.77	.52	49.18	591.01	520.63	17.913	27.949	17.913	1.0541
3	.72	.47	45.30	591.01	527.70	18.812	28.046	18.812	1.0487
4	.68	.40	40.13	591.01	535.59	19.893	28.230	19.893	1.0418
5	.68	.35	34.20	591.01	541.63	20.898	28.358	20.898	1.0368



SET PAGE RPM TOTAL/STATIC INLET TOTAL INLET TOTAL  
 NUMBER NUMBER NUMBER PRESSURE RATIO PRESSURE (PSI) TEMPERATURE (DEC. R) TEMPERATURE (DEC. R)

1 2 15000.0 2.000 29.400 591.01

ROTOR EXIT SOLUTION

STREAM LINE	RADIAL POSITION	X=R/RM	SHIFT	RADIAL OPENING	BLADE	Y=VA /VAM	EFFICIENCY	COEFFICIENT	CONTINUITY	FRACTION RATE
1	2.693	.825	.0710	.1912	.9831	.8557	1.443	.1473	.1473	0.0000
2	3.020	.925	-.0168	.2218	.9567	.8627	1.173	.1374	.1374	.2313
3	3.265	1.000	-.0405	.2447	1.0000	.8680	1.320	.1320	.1320	.4293
4	3.585	1.078	-.1537	.2747	1.0885	.8750	1.250	.1250	.1250	.7243
5	3.837	1.175	-.2100	.2983	1.1810	.8805	.1195	.1195	.1195	1.0000

ABSOLUTE VELOCITY (FPS)

STREAM LINE	AXIAL COMPONENT	RADIAL COMPONENT	TANGENTIAL COMPONENT	OVERALL VELOCITY	AXIAL COMPONENT	RADIAL COMPONENT	TANGENTIAL COMPONENT	OVERALL VELOCITY	WHEEL VELOCITY
1	312.83	-12.55	-400.31	508.20	312.83	-12.55	-752.83	815.33	352.51
2	304.44	2.89	-304.04	430.27	304.44	2.89	-499.34	773.74	352.51
3	318.22	7.28	-279.21	423.41	318.22	7.28	-706.50	774.90	426.33
4	346.38	30.08	-54.97	431.15	346.38	30.08	-724.50	801.42	426.33
5	375.82	44.59	-248.55	452.78	375.82	44.59	-750.81	840.81	502.26

MACH NUMBER FLOW ANGLE (DEG) TEMPERATURE (DEG. R) PRESSURE (PSI) PRESSURE RATIO

STREAM LINE	ABSOLUTE	RELATIVE	ABSOLUTE	RELATIVE	TOTAL	STATIC	TOTAL	STATIC	TOT/TOI	TOT/STA
1	.47	.75	-52.00	-67.48	513.94	492.45	15.931	13.719	1.8555	2.1431
2	.49	.71	-41.97	-65.76	516.50	501.97	16.478	14.821	1.7847	1.9847
3	.49	.71	-41.27	-64.45	516.03	501.35	16.529	14.942	1.7787	1.9676
4	.41	.77	-39.36	-63.41	515.82	500.35	16.604	14.926	1.7706	1.9697
5	.41	.77	-33.48	-63.41	515.19	498.13	16.574	14.731	1.7739	1.9958

STREAM LINE EQUIVALENT TEMPERATURE (DEC. R) EQUIVALENT INLET PRESSURE (PSI) EQUIVALENT PRESSURE RATIO

1	547.77	21.291	1.6
2	549.31	21.610	1.5
3	551.33	21.942	1.5
4	554.07	22.513	1.5
5	556.96	23.039	1.6



SET NUMBER	PAGE NUMBER	RPM	TOTAL/STATIC PRESSURE RATIO	INLET TOTAL PRESSURE (PSI)	INLET TOTAL TEMPERATURE (DEG. R)
1	3	15000.0	2.000	29.400	591.01

OVERALL TURBINE CHARACTERISTICS

STREAM LINE	PRESSURE RATIO TOT/ST1	EFFICIENCY TOT/ST1	HEAD COEFFICIENT	BLADE/NET SPEED RATIO	THEORETICAL DEGREE OF REACTION
1	2.1431	1.8455	10.6175	30.69	.2421
2	1.9837	1.7842	8.1692	3.499	.3471
3	1.9676	1.7787	7.1371	3.741	.3222
4	1.9697	1.7706	6.1975	4.017	.4075
5	1.9958	1.7739	5.6453	4.209	.4812

MASS AVERAGED QUANTITIES

HORSE POWER = 98.79 (HP)  
 MOMENT FLOW RATE = 34.59 (FT-LB) (LB/SEC)  
 REFERRED RPM = 14098.38  
 REFERRED HORSE POWER = 46.26 (HP)  
 REFERRED MOMENT FLOW RATE = 17.29 (FT-LB) (LB/SEC)

TOTAL/STATIC EFFICIENCY = .7116  
 TOTAL/TOTAL EFFICIENCY = .8352  
 TOTAL/STATIC PRESSURE RATIO = 1.9976  
 TOTAL/TOTAL PRESSURE RATIO = 1.7858

HEAD COEFFICIENT = 7.4088  
 BLADE/JET SPEED RATIO = 3.674  
 THEORETICAL DEGREE OF REACTION = .3372  
 MACH NUMBER AT STATION 0 = .2057





SET PAGE RPM TOTAL/STATIC INLET TOTAL INLET TOTAL  
 NUMBER NUMBER 20000.0 PRESSURE RATIO PRESSURE TEMPERATURE TEMPERATURE  
 1 1 2.000 591.01

STATOR EXIT SOLUTION

STREAM LINE	RADIAL POSITION (IN)	X=R/RH	RADIAL SHIF (IN)	BLADE OPENING (IN)	Y=VA /VAM	BLADE EFFICIENCY	LOSS COEFFICIENT	Z/FIX*	CONTINUITY	FLOW RATE FRACTION
1	3.764	.865	0.0000	.2126	1.1007	.9008	.0912	.0912	.0912	0.0000
2	3.003	.940	0.0000	.2347	1.0465	.9064	.0936	.0936	.0936	.2543
3	3.195	1.000	0.0290	.2526	1.0000	.9045	.0955	.0955	.0955	.4742
4	3.432	1.074	0.0000	.2745	.9406	.9034	.0966	.0966	.0966	.7576
5	3.627	1.135	0.0000	.2926	.8914	.9024	.0976	.0976	.0976	1.0000

RELATIVE VELOCITY (FPS)

STREAM LINE	AXIAL COMPONENT	TANGENTIAL COMPONENT	OVERALL VELOCITY	RADIAL COMPONENT	TANGENTIAL COMPONENT	OVERALL VELOCITY	WHEEL VELOCITY
1	392.34	866.69	951.49	-15.74	384.28	549.41	482.41
2	373.02	814.87	896.20	3.54	290.73	472.95	524.14
3	361.55	771.71	850.09	8.16	213.99	420.21	557.73
4	335.27	720.07	794.83	29.12	121.13	352.67	598.94
5	317.71	677.85	749.56	37.69	44.62	323.06	633.03

MACH NUMBER FLOW ANGLE (DEG. R)

STREAM LINE	ABSOLUTE	RELATIVE	ABSOLUTE	RELATIVE	TEMPERATURE (DEG. R)	TEMPERATURE (DEG. R)	PRESSURE (PSI)	PRESSURE RATIO
	ABSOLUTE	RELATIVE	TOTAL	STATIC	TOTAL	STATIC	TOTAL	TOT/STA
1	.85	.49	591.01	515.68	27.919	17.323	1.0510	1.6971
2	.80	.42	591.01	524.10	28.088	19.343	1.0470	1.6942
3	.75	.37	591.01	530.88	28.139	20.858	1.0374	1.6814
4	.70	.31	591.01	538.44	28.455	21.325	1.0332	1.6733
5	.66	.28	591.01	544.26				1.6786



SET NUMBER PAGE NUMBER RPM TORQUE/RATIO INLET TOTAL TEMPERATURE TOTAL PRESSURE (PSI) PRESSURE (PSI) (DEG. R) 591.01

1 2 20000.0 2.000 29.400

ROTOR EXIT SOLUTION

STREAM LINE	RADIAL POSITION	X=R/RM	RADIAL SHIFT	BLADE OPENING	Y=VA /VAM	EFFICIENCY	LOSS COEFFICIENT	CONTRIBUTION*	FLOW RATE FRACTION
1	3.693	.825	.0710	.1912	.9898	.0030	.1162	.1162	0.0000
2	3.020	.925	-.0148	.2216	.9301	.0230	.1130	.1110	.2267
3	3.260	1.000	-.0405	.2447	1.0000	.0279	.1071	.1071	.4230
4	3.582	1.098	-.1537	.2747	1.1264	.0880	.1121	.1121	.7188
5	3.837	1.175	-.2100	.2983	1.2511	.0841	.1159	.1159	1.0000

ABSOLUTE VELOCITY (FPS)

STREAM LINE	AXIAL COMPONENT	RADIAL COMPONENT	TANGENTIAL COMPONENT	OVERALL VELOCITY	AXIAL COMPONENT	RADIAL COMPONENT	TANGENTIAL COMPONENT	OVERALL VELOCITY	WHEEL VELOCITY
1	307.44	-12.33	-269.85	409.26	307.44	-12.33	-239.87	801.38	470.02
2	288.90	2.74	-136.58	319.52	288.90	2.74	-663.65	723.81	527.07
3	310.61	7.11	-119.86	333.82	310.61	7.11	-689.71	756.46	565.85
4	349.86	30.39	-105.81	366.78	349.86	30.39	-231.58	811.50	655.77
5	388.62	46.11	-106.70	405.63	388.62	46.11	-276.38	869.44	669.68

MACH NUMBER FLOW ANGLE (DEG)

STREAM LINE	ABSOLUTE	RELATIVE	ABSOLUTE	RELATIVE	TEMPERATURE (DEG. R)	TEMPERATURE (PSI)	PRESSURE RATIO
1	.38	.74	-41.28	-67.44	TOTAL	STATIC	TOTAL/101
2	.29	.66	-25.30	-66.48	500.32	486.38	1.9851
3	.30	.69	-21.10	-65.76	507.95	499.45	1.8493
4	.34	.74	-16.83	-64.45	508.01	499.09	1.9618
5	.37	.80	-15.35	-63.41	508.22	497.02	1.9631
					507.71	494.01	1.8479
						15.762	1.8652
						14.324	2.0525

EQUIVALENT INLET PRESSURE (PSI)

STREAM LINE	EQUIVALENT INLET PRESSURE (PSI)	EQUIV/STATIC PRESSURE RATIO
1	20.331	1.5
2	20.872	1.4
3	21.460	1.4
4	22.289	1.5
5	23.112	1.6



SET NUMBER	PAGE NUMBER	RPM	TOTAL/STATIC PRESSURE RATIO	INLET TOTAL PRESSURE (PSI)	INLET TOTAL TEMPERATURE (DEG. R)
1	3	20000.0	2.000	29.400	591.01

OVERALL TURBINE CHARACTERISTICS

STREAM LINE	PRESSURE RATIO TOT/STA	TOT/STA	EFFICIENCY TOT/TOT	HEAD COEFFICIENT	SLADE/JET SPEED RATIO	THEORETICAL DEGREE OF REACTION
1	1.9851	.7642	.8625	6.1204	.4039	.3015
2	1.9618	.8025	.8724	4.5275	.4700	.2876
3	1.8442	.8017	.8754	3.9997	.5000	.3578
4	1.9977	.7810	.8706	3.5516	.5306	.4511
.5	2.0525	.7590	.8640	3.2914	.5512	.5280

MASS AVERAGED QUANTITIES

HORSE POWER =	109.74 (HP)
MOMENT FLOW RATE =	28.82 (FT-LB) (LB/SEC)
REFERRED RPM =	18731.18
REFERRED HORSE POWER =	51.39 (HP)
REFERRED MOMENT FLOW RATE =	14.41 (FT-LB) (LB/SEC)

TOTAL/STATIC EFFICIENCY =	.7067
TOTAL/STATIC PRESSURE RATIO =	.8704
TOTAL/STATIC PRESSURE RATIO =	2.0109
TOTAL/STATIC PRESSURE RATIO =	1.8666
HEAD COEFFICIENT =	4.1972
SLADE/JET SPEED RATIO =	.4881
THEORETICAL DEGREE OF REACTION =	.3728
MACH NUMBER AT STATION 0	.2052



SET PAGE RPM TOTAL/STATIC INLET TOTAL INLET TOTAL  
 NUMBER NUMBER 25000.0 PRESSURE RATIO PRESSURE TEMPERATURE TEMPERATURE  
 1 1 2.000 591.01

STATOR EXIT SOLUTION

STREAM LINE	RADIAL POSITION (IN)	X=R/RM	RADIAL SHIFT (IN)	BLADE OPENING (IN)	BLADE EFFICIENCY	Y=VA /VAM	LOSS COEFFICIENT	ZETA*	CONTINUITY	FLOW RATE FRACTION
1	2.764	.865	0.0000	.2126	.9134	1.1023	.0866	.0866	0.0000	
2	3.003	.840	0.0000	.2347	.9101	1.0472	.0899	.0899	.2553	
3	3.195	1.000	0.0000	.2526	.9075	1.0000	.0925	.0925	.4754	
4	3.432	1.074	0.0000	.2745	.9058	1.9401	.0942	.0942	.7584	
5	3.627	1.135	0.0000	.2926	.9044	.8904	.0956	.0956	1.0000	

RELATIVE VELOCITY (FPS)

STREAM LINE	AXIAL COMPONENT	RADIAL COMPONENT	TANGENTIAL COMPONENT	OVERALL VELOCITY	AXIAL COMPONENT	RADIAL COMPONENT	TANGENTIAL COMPONENT	OVERALL VELOCITY	WHEEL VELOCITY
1	386.00	-15.48	852.69	936.12	386.00	-15.48	249.68	459.98	603.01
2	366.71	3.48	801.07	881.02	366.71	3.48	145.90	394.68	655.17
3	350.19	8.01	758.19	835.20	350.19	8.01	61.04	355.56	697.15
4	329.20	28.52	702.04	780.45	329.20	28.52	-125.69	333.05	748.67
5	311.83	39.00	665.30	735.68	311.83	39.00		338.35	791.29

TEMPERATURE (DEG. R)

STREAM LINE	ABSOLUTE	RELATIVE	FLOW ANGLE (DEG.)	TEMPERATURE (DEG. R)	STATIC	TOTAL	PRESSURE RATIO
1	.84	.41	65.65	591.01	518.09	28.049	1.0482
2	.74	.31	65.41	591.01	533.42	28.123	1.0416
3	.68	.29	65.04	591.01	540.33	28.408	1.0349
4	.64	.30	64.89	591.01	545.97	28.512	1.0311
5			-22.00				1.3608





SET NUMBER PAGE RPM LOGIAL/STATIC PRESSURE INLET TOTAL INLET TOTAL  
 NUMBER NUMBER PRESSURE (PSI) TEMPERATURE (DEG. R) TEMPERATURE (DEG. R)

1 2 25000.0 2.000 29.400 591.001 591.001

ROTOR EXIT SOLUTION

STREAM LINE	RADIAL POSITION	X=R/RM	SHIFT	RADIAL OPENING	BLADE	Y=VA	WARM	EFFICIENCY	COEFFICIENT	LOSS	CONTINUITY	FRACTION RATE
1	2.693	.825	.0710	.1943	.9982	.9019	.0981	.0981	.0981	.0981	.0981	0.0000
2	3.020	.925	-.0168	.2218	.9020	.6912	.1089	.1089	.1089	.1089	.1089	.2209
3	3.265	1.000	-.0405	.2447	1.0000	.8031	.1970	.1970	.1970	.1970	.1970	.4114
4	3.585	1.098	-.1537	.2747	1.1473	.8871	.1139	.1139	.1139	.1139	.1139	.7094
5	3.887	1.175	-.2100	.2983	1.3260	.8885	.1115	.1115	.1115	.1115	.1115	1.0000

ABSOLUTE VELOCITY (FPS)

RELATIVE VELOCITY (FPS)

STREAM LINE	AXIAL COMPONENT	RADIAL COMPONENT	TANGENTIAL COMPONENT	OVERALL VELOCITY	AXIAL COMPONENT	RADIAL COMPONENT	TANGENTIAL COMPONENT	OVERALL VELOCITY	WHEEL VELOCITY
1	300.44	-12.05	-135.50	329.81	300.44	-12.05	-723.03	783.06	537.52
2	271.49	-2.58	37.19	273.28	271.49	2.58	-623.66	680.19	658.84
3	301.90	6.89	43.26	304.27	301.90	6.89	-658.56	712.31	712.31
4	351.34	30.51	47.55	355.85	351.34	30.51	-734.67	814.93	814.93
5	399.12	47.35	39.75	403.88	399.12	47.35	-797.35	892.92	837.11

MACH NUMBER

FLOW ANGLE (DEG)

TEMPERATURE (DEG. R)

PRESSURE RATIO

STREAM LINE	ABSOLUTE	RELATIVE	ABSOLUTE	RELATIVE	TOTAL	STATIC	TOTAL	STATIC	TOT/TOT	TOT/STA
1	.31	.73	-24.28	-67.44	492.19	483.14	14.198	13.305	2.0787	2.2097
2	.25	.62	7.39	-66.48	507.52	501.20	15.995	15.318	1.8381	1.9194
3	.28	.67	8.31	-65.76	508.25	500.55	15.995	15.162	1.8381	1.9350
4	.33	.74	7.71	-64.45	509.10	498.57	16.028	14.896	1.8443	1.9737
5	.37	.82	5.69	-63.41	508.94	495.36	15.922	14.484	1.8465	2.0298

EQUIVALENT INLET PRESSURE (PSI)

EQUIVALENT INLET PRESSURE (PSI)

EQUIVALENT TEMPERATURE (DEG. R)

EQUIV/STATIC PRESSURE RATIO

1	534.16	19.687	1.5
2	539.78	20.512	1.3
3	545.26	21.326	1.4
4	553.83	22.629	1.5
5	561.71	23.864	1.6



SET NUMBER    PAGE NUMBER    RPM    TOTAL/STATIC PRESSURE RATIO    INLET TOTAL PRESSURE (PSI)    INLET TOTAL TEMPERATURE (DEG. R)

1    3    25000.0    2.000    29.400    591.01

OVERALL TURBINE CHARACTERISTICS

STREAM LINE	PRESSURE RATIO TOT/STA	TOT/101	EFFICIENCY TOT/101	HEAD COEFFICIENT TOT/101	BLADE/JET SPEED RATIO	THEORETICAL DEGREE OF REACTION
1	2.2097	2.0707	.8905	3.9591	1.5026	.3835
2	1.6194	1.8381	.8950	2.8123	1.5763	.3934
3	1.6190	1.8361	.8772	2.5189	.6301	.3721
4	1.6737	1.8343	.8708	2.2371	.6686	.4637
5	2.0298	1.8465	.7584	2.0771	.6959	.5399

MASS AVERAGED QUANTITIES

HORSE POWER = 108.40 (HP)  
 MOMENT FLOW RATE = 22.79 (FT-LB) (LB/SEC)  
 REFERRED RPM = 23413.97 (HP)  
 REFERRED HORSE POWER = 50.80 (HP)  
 REFERRED MOMENT FLOW RATE = 11.40 (FT-LB) (LB/SEC)  
 REFERRED FLOW RATE = 2.02 (LB/SEC)

TOTAL/STATIC EFFICIENCY = .8051  
 TOTAL/STATIC EFFICIENCY = .8776  
 TOTAL/STATIC PRESSURE RATIO = 1.9879  
 TOTAL/STATIC PRESSURE RATIO = 1.8673

HEAD COEFFICIENT = 2.6465  
 BLADE/JET SPEED RATIO = .6147  
 THEORETICAL DEGREE OF REACTION = .3915  
 MACH NUMBER AT STATION 0 = .2016



SET PAGE RPM TOTAL/STATIC INLET TOTAL INLET TOTAL  
 NUMBER NUMBER 30000.0 PRESSURE RATIO PRESSURE TEMPERATURE PRESSURE TEMPERATURE  
 1 1 2.000 29.400 591.001 591.001

STATOR EXIT SOLUTION

STREAM LINE	RADIAL POSITION (IN)	X=R/RM	RADIAL SHIFT (IN)	BLADE OPENING (IN)	BLADE EFFICIENCY	Y=VA /VAM	LOSS COEFFICIENT	ZETA* CONTINUITY	FLOW RATE FRACTION
1	2.764	.865	0.0000	.2126	.9201	1.1043	.0799	.0799	0.0000
2	3.063	.940	0.0000	.2127	.9196	1.0480	.0844	.0844	.2548
3	3.192	1.000	0.0000	.2128	.9192	1.0000	.0881	.0881	.4748
4	3.432	1.074	0.0000	.2129	.9095	.9393	.0905	.0905	.7580
5	3.627	1.135	0.0000	.2126	.9075	.8893	.0925	.0925	1.0000

RELATIVE VELOCITY (FPS)

STREAM LINE	AXIAL COMPONENT	RADIAL COMPONENT	TANGENTIAL COMPONENT	OVERALL VELOCITY	AXIAL COMPONENT	RADIAL COMPONENT	TANGENTIAL COMPONENT	OVERALL VELOCITY	WHEEL VELOCITY
1	397.01	-15.93	877.02	962.83	397.01	-15.93	153.40	425.62	723.62
2	376.77	3.58	823.06	905.21	376.77	3.58	36.85	378.59	786.21
3	352.11	8.23	778.40	857.45	352.11	8.23	-58.10	356.98	836.58
4	337.72	29.33	725.33	800.63	337.72	29.33	-173.08	380.62	898.41
5	319.71	37.93	682.12	754.28	319.71	37.93	-267.43	418.53	949.55

TEMPERATURE (DEG. R)

STREAM LINE	ABSOLUTE	RELATIVE	STATIC	TOTAL	STATIC	TOTAL	10T/10T	10T/STA	PRESSURE RATIO
1	.87	65.65	513.87	591.01	28.080	17.211	1.0470	1.7082	
2	.81	65.41	523.83	591.01	28.181	18.349	1.0431	1.6022	
3	.76	65.21	529.83	591.01	28.268	19.284	1.0400	1.5246	
4	.70	65.04	537.67	591.01	28.397	20.394	1.0357	1.4416	
5	.66	64.89	543.67	591.01	28.497	21.276	1.0317	1.3816	



SET PAGE RPM TOTAL/STATIC INLET TOTAL INLET TOTAL  
 NUMBER NUMBER PRESSURE RATIO PRESSURE (PSI) TEMPERATURE (DEC. R) TEMPERATURE (DEC. R)

1 2 30000.0 2.000 29.400 591.01

KOTOR EXIT SOLUTION

STREAM LINE	RADIAL POSITION	X=R/RM	RADIAL SHIFT	BLADE OPENING	Y=VA/VAM	EFFICIENCY	COEFFICIENT	CONTINITY	FLOW RATE FRACTION
1	2.693	.825	.0710	.1912	1.0060	.9114	.0686	.0086	0.0000
2	3.020	.925	-.0168	.2318	1.8756	.8932	.1069	.1069	.2130
3	3.265	1.000	-.0405	.2447	1.0000	.8795	.1206	.1206	.3983
4	3.585	1.098	-.1537	.2747	1.2080	.8912	.1089	.1089	.6982
5	3.837	1.175	-.2100	.2983	1.4017	.9004	.0997	.0997	1.0000

ABSOLUTE VELOCITY (FPS)

STREAM LINE	AXIAL COMPONENT	RADIAL COMPONENT	TANGENTIAL VELOCITY	OVERALL VELOCITY	AXIAL COMPONENT	RADIAL COMPONENT	TANGENTIAL COMPONENT	OVERALL VELOCITY	WHEEL VELOCITY
1	297.96	-11.95	-12.01	298.44	297.96	-11.95	-12.04	276.57	705.03
2	259.34	2.46	194.87	324.40	259.34	2.46	-595.75	649.75	705.03
3	296.19	6.78	197.09	355.84	296.19	6.78	-657.69	721.34	838.78
4	357.80	31.68	190.49	406.53	357.80	31.68	-748.16	824.90	838.78
5	415.16	49.26	175.12	453.27	415.16	49.26	-829.40	928.81	1004.53

MACH NUMBER FLOW ANGLE (DEC)

STREAM LINE	ABSOLUTE	RELATIVE	ABSOLUTE	RELATIVE	TEMPERATURE (DEC. R)	PRESSURE (PSI)	STATIC	TOTAL	STATIC	TOT/TOT	TOT/STA
1	.28	.73	-26.92	-67.48	483.98	476.57	13.441	13.253	12.253	2.1041	2.3053
2	.30	.66	32.64	-66.48	508.96	500.50	16.460	16.257	15.260	1.8131	1.9267
3	.32	.66	28.64	-65.76	512.32	499.50	16.557	16.367	15.367	1.8084	1.9313
4	.37	.76	22.87	-63.45	512.32	499.57	16.520	16.320	14.520	1.7938	1.9710
5	.42	.85	22.87	-63.41	512.49	495.40	16.551	16.351	14.520	1.7981	2.0248

EQUIVALENT INLET PRESSURE (PSI) EQUIVALENT TEMPERATURE (DEC. R)

1	18.769	1.5
2	19.792	1.3
3	21.014	1.4
4	22.715	1.5
5	24.675	1.7





SET NUMBER	PAGE NUMBER	RPM	TOTAL/STATIC PRESSURE RATIO	INLET TOTAL PRESSURE (PSI)	INLET TOTAL TEMPERATURE (DEG. R)
1	3	30000.0	2.000	29.400	591.01

OVERALL TURBINE CHARACTERISTICS

STREAM LINE	PRESSURE RATIO TOT/STA	TOT/10T	EFFICIENCY TOT/10T	HEAD COEFFICIENT	BLADE/JET SPEED RATIO	THEORETICAL DEGREE OF REACTION
1	2.3053	2.1841	.9053	2.8795	.5093	.3317
2	1.9267	1.8131	.8880	1.9632	.7137	.2625
3	1.9513	1.8084	.8730	1.7644	.7528	.3471
4	1.9730	1.7938	.8660	1.5528	.8025	.4377
5	2.0248	1.7981	.8608	1.4379	.8339	.5164

MASS AVERAGED QUANTITIES

HORSE POWER =	105.42 (HP)
MOMENT =	18.46 (FT-LB)
FLOW RATE =	3.75 (LB/SEC)
REFERRED RPM =	28096.77
REFERRED HORSE POWER =	49.37 (HP)
REFERRED MOMENT =	9.23 (FT-LB)
REFERRED FLOW RATE =	2.00 (LB/SEC)

TOTAL/STATIC EFFICIENCY =	.7809
TOTAL/STATIC PRESSURE RATIO =	2.0040
TOTAL/STATIC PRESSURE RATIO =	1.8516

HEAD COEFFICIENT =	1.8598
BLADE/JET SPEED RATIO =	1.7333
THEORETICAL DEGREE OF REACTION =	.3678
MACH NUMBER AT STATION 0 =	1.1995



SET PAGE RPM TOTAL/STATIC INLET TOTAL INLET TOTAL  
 NUMBER NUMBER 15000.0 PRESSURE RATIO PRESSURE TEMPERATURE  
 1 1 2.200 32.340 603.60

STATOR EXIT SOLUTION

STREAM LINE	RADIAL POSITION (IN)	X=R/RM	RADIAL SHIFT (IN)	BLADE OPENING (IN)	Y=VA /VAM	EFFICIENCY	LOSS COEFFICIENT	ZETA*	CONTINUITY	FLOW RATE FRACTION
1	2.764	.865	0.0000	.2126	1.1032	.9106	.0894	.0894	0.0000	
2	3.093	.740	0.0000	.2347	1.0873	.9052	.0948	.0948	.2520	
3	3.132	1.070	0.0000	.2526	1.0000	.9008	.0992	.0992	.4710	
4	3.422	1.074	0.0000	.2745	.9408	.9002	.0998	.0998	.7552	
5	3.627	1.135	0.0000	.2926	.8920	.8996	.1004	.1004	1.0000	

ABSOLUTE VELOCITY (FPS)

STREAM LINE	AXIAL COMPONENT	RADIAL COMPONENT	TANGENTIAL COMPONENT	OVERALL VELOCITY	COMPONENT	AXIAL COMPONENT	RADIAL COMPONENT	TANGENTIAL COMPONENT	OVERALL VELOCITY	WHEEL VELOCITY
1	427.56	-17.15	944.51	1036.92	427.56	-17.15	502.70	722.94	361.81	
2	405.92	3.86	866.73	975.24	405.92	3.86	493.63	639.11	393.10	
3	387.58	8.87	839.15	924.37	307.58	8.87	420.86	572.20	418.29	
4	364.63	31.67	783.13	864.44	364.63	31.67	333.93	495.44	442.20	
5	345.74	41.02	737.65	815.69	345.74	41.02	262.88	436.26	474.77	

100

MACH NUMBER

STREAM LINE	ABSOLUTE	RELATIVE	ABSOLUTE	RELATIVE	TOTAL	STATIC	TEMPERATURE (DEG. R)	TOTAL	STATIC	100/101	100/51A
1	.93	.65	65.65	53.73	603.60	514.13	30.446	17.365	1.0622	1.8674	
2	.82	.57	65.41	50.57	603.60	524.46	30.586	18.702	1.0574	1.7992	
3	.76	.51	65.21	47.36	603.60	532.50	30.707	19.803	1.0532	1.7431	
4	.71	.43	65.04	42.49	603.60	541.42	30.921	21.135	1.0459	1.6102	
5	.65	.38	64.89	37.25	603.60	548.24	31.082	22.196	1.0405	1.4570	

RELATIVE VELOCITY (FPS)

TEMPERATURE (DEG. R)

TEMPERATURE (DEG. R)

TEMPERATURE (DEG. R)

TEMPERATURE (DEG. R)



SET NUMBER PAGE RPM TOTAL/STATIC PRESSURE INLET TOTAL INLET TOTAL  
 NUMBER NUMBER PRESSURE RATIO PRESSURE (PSI) TEMPERATURE (DEG. R) TEMPERATURE (DEG. R)

1 2 15000.0 2.200 32.340 603.600

MOTOR EXIT SOLUTION

STREAM LINE	RADIAL POSITION	X=R/RM	RADIAL SHIFT	BLADE OPENING	BLADE EFFICIENCY	Y=VA /VAM	BLADE EFFICIENCY	LOSS COEFFICIENT	ZETA*	CONTINUITY	FLOW RATE FRACTION
1	2.693	.825	.0710	.1912	.8565	.9817	.8565	.1436	.1436	.1436	0.0000
2	3.020	.925	-.0168	.2218	.8224	.9631	.8224	.1376	.1376	.1376	.2117
3	3.265	1.000	-.0405	.2447	.8669	1.0000	.8669	.1331	.1331	.1331	.4304
4	3.585	1.098	-.1537	.2747	.8754	1.0807	.8754	.1247	.1247	.1247	.7254
5	3.837	1.175	-.2100	.2983	.8820	1.1669	.8820	.1180	.1180	.1180	1.0000

RELATIVE VELOCITY (FPS)

ABSOLUTE VELOCITY (FPS)

STREAM LINE	AXIAL COMPONENT	RADIAL COMPONENT	TANGENTIAL COMPONENT	OVERALL VELOCITY	AXIAL COMPONENT	RADIAL COMPONENT	TANGENTIAL COMPONENT	OVERALL VELOCITY	OVERALL VELOCITY	WHEEL VELOCITY
1	340.83	-13.67	-462.70	578.87	340.83	-13.67	-820.21	888.31	888.31	352.51
2	334.18	3.18	-372.80	500.80	334.18	3.18	-768.11	837.74	837.74	395.31
3	342.19	7.94	-343.55	488.50	342.19	7.94	-770.93	845.55	845.55	427.39
4	375.22	32.59	-315.28	491.18	375.22	32.59	-784.61	870.33	870.33	469.33
5	405.14	48.07	-307.12	510.66	405.14	48.07	-809.38	906.39	906.39	502.26

MACH NUMBER FLOW ANGLE (DEG)

TEMPERATURE (DEG. R)

PRESSURE RATIO

STREAM LINE	ABSOLUTE	RELATIVE	ABSOLUTE	RELATIVE	TOTAL	STATIC	TOTAL	STATIC	TOTAL	STATIC
1	.53	.82	-53.92	-67.44	519.29	491.41	16.612	13.694	101/101	101/514
2	.46	.76	-48.11	-66.48	521.06	500.19	17.117	14.835	1.9468	2.3617
3	.45	.77	-44.70	-65.76	520.75	500.89	17.172	14.988	1.8033	2.1799
4	.45	.79	-40.04	-64.45	520.43	500.35	17.274	15.052	1.8037	2.1528
5	.47	.83	-37.17	-63.41	519.64	497.94	17.246	14.854	1.8722	2.1485

STREAM LINE	EQUIVALENT TEMPERATURE (DEG. R)	EQUIVALENT INLET PRESSURE (PSI)	EQUIV/STATIC PRESSURE RATIO
1	557.07	22.993	1.7
2	558.59	23.320	1.6
3	560.38	23.676	1.6
4	563.38	24.291	1.6
5	566.31	24.864	1.7



SET NUMBER	PAGE NUMBER	RPM	TOTAL/STATIC PRESSURE RATIO	INLET PRESSURE (PSI)	TOTAL TEMPERATURE (DEG. R)	INLET TEMPERATURE (DEG. R)
1	3	15000.0	2.200	32.340	603.60	

OVERALL TURBINE CHARACTERISTICS

STREAM LINE	PRESSURE RATIO TOT/STA	EFFICIENCY TOT/TOT	HEAD COEFFICIENT TOT/TOT	BLADE/INLET SPEED RATIO	THEORETICAL DEGREE OF REACTION
1	2.3617	.8059	12.0635	.2879	.2523
2	2.3799	.8237	6.1364	.3267	.2743
3	2.1578	.8297	6.1291	.3472	.3371
4	2.1486	.8400	7.0850	.3265	.4170
5	2.1772	.8460	6.4139	.3949	.4884

MASS AVERAGED QUANTITIES

HORSE POWER = 118.32 (HP)  
 MOMENT = 41.43 (FT-LB)  
 FLOW RATE = 4.19 (LB/SEC)

REFERRED RPM = 13901.10 (HP)  
 REFERRED HORSE POWER = 49.84 (FT-LB)  
 REFERRED MOMENT = 18.83 (LB/SEC)  
 REFERRED FLOW RATE = 2.05 (LB/SEC)

TOTAL/STATIC EFFICIENCY = .6882  
 TOTAL/TOTAL EFFICIENCY = .8256  
 TOTAL/STATIC PRESSURE RATIO = 3.1889

HEAD COEFFICIENT = 8.4406  
 BLADE/JET SPEED RATIO = .3438  
 THEORETICAL DEGREE OF REACTION = .3497  
 MACH NUMBER AT STATION 0 = .2049





SET NUMBER 1 PAGE 1 RPM 20000.0  
 INLET/STATIC PRESSURE RATIO 2.200  
 INLET TOTAL PRESSURE 32.340  
 INLET TOTAL TEMPERATURE 603.60

STAIR EXIT SOLUTION

STREAM LINE	RADIAL POSITION (IN)	X=R/RM	RADIAL SHIFT (IN)	BLADE OPENING (IN)	BLADE EFFICIENCY	LOSS COEFFICIENT	ZETA* CONTINUITY	FLOW RATE FRACTION
1	2.764	.865	0.0000	.2126	.9111	.0889	.0089	0.0000
2	3.003	.940	0.0000	.2347	.9081	.0919	.0619	.2530
3	3.175	1.000	0.0000	.2526	.9057	.0943	.0943	.4724
4	3.432	1.074	0.0000	.2745	.9045	.0955	.0955	.7564
5	3.627	1.135	0.0000	.2926	.9035	.0965	.0965	1.0000

STREAM LINE	ABSOLUTE VELOCITY (FPS)				RELATIVE VELOCITY (FPS)			
	AXIAL COMPONENT	RADIAL COMPONENT	TANGENTIAL COMPONENT	OVERALL VELOCITY	AXIAL COMPONENT	RADIAL COMPONENT	TANGENTIAL COMPONENT	OVERALL VELOCITY
1	414.03	-16.61	914.61	1004.10	414.03	-16.61	432.20	590.75
2	393.50	3.74	859.60	945.39	393.50	3.74	325.46	517.10
3	381.15	8.60	813.88	896.54	381.15	8.60	256.16	459.31
4	353.54	30.71	759.31	838.14	353.54	30.71	160.37	389.42
5	335.01	39.75	714.75	790.37	335.01	39.75	81.77	347.11

STREAM LINE	MACH NUMBER		FLOW ANGLE (DEG)		TEMPERATURE (DEG. R)		PRESSURE (PSI)		PRESSURE RATIO
	ABSOLUTE	RELATIVE	ABSOLUTE	RELATIVE	TOTAL	STATIC	TOTAL	STATIC	
1	.90	.54	65.65	46.23	603.60	519.70	30.592	18.119	1.0572
2	.84	.46	65.41	40.45	603.60	529.23	30.759	19.413	1.0514
3	.79	.40	65.21	33.91	603.60	536.73	30.896	20.483	1.0469
4	.73	.34	65.04	24.40	603.60	545.15	31.072	21.757	1.0424
5	.69	.30	64.89	13.71	603.60	551.62	31.215	22.776	1.0360



SET NUMBER 1 2 20000.0 RPM PRESSURE RATIO 2.200 INLET TOTAL PRESSURE (PSI) 32.340 INLET TOTAL TEMPERATURE (DEG. R) 603.60

ROTOR EXIT SOLUTION

STREAM LINE	RADIAL POSITION	X=R/RM	RADIAL OPENING	BLADE EFFICIENCY	LOSS COEFFICIENT	Z/10*	CONTINUITY	FLOW RATE FRACTION
1	2.693	.825	.0710	.8922	.1148	.1148	0.0000	
2	3.023	.925	-.0168	.8926	.1104	.1104	.2272	
3	3.265	1.000	-.0405	.8929	.1071	.1071	.4235	
4	3.585	1.092	-.0537	.8985	.1014	.1014	.7201	
5	3.837	1.175	-.0210	.9030	.0970	.0970	1.0000	

ABSOLUTE VELOCITY (FPS) RELATIVE VELOCITY (FPS)

STREAM LINE	AXIAL COMPONENT	TANGENTIAL COMPONENT	OVERALL VELOCITY	AXIAL COMPONENT	RADIAL COMPONENT	TANGENTIAL COMPONENT	OVERALL VELOCITY	WHEEL VELOCITY
1	338.22	-343.92	482.56	338.22	-13.57	-613.94	881.52	470.02
2	321.59	-211.66	385.01	321.59	3.06	-738.74	805.71	527.02
3	342.46	-190.57	391.99	342.46	7.84	-760.42	854.01	562.97
4	381.20	-171.35	419.25	381.20	33.11	-697.11	884.20	632.97
5	419.97	-169.33	455.56	419.97	49.83	-839.02	939.58	669.68

MACH NUMBER FLOW ANGLE (DEG)

STREAM LINE	ABSOLUTE	RELATIVE	ABSOLUTE	RELATIVE
1	.45	.82	-45.48	-67.44
2	.35	.74	-33.35	-66.48
3	.36	.76	-29.10	-65.76
4	.38	.81	-24.20	-64.45
5	.42	.86	-21.96	-63.41

TEMPERATURE (DEG. R)

STREAM LINE	TOTAL	STATIC	TOTAL	STATIC	TOT/TOT	101/STIA
1	503.27	483.89	15.230	13.274	2.1235	2.4663
2	510.05	497.72	16.270	14.934	1.9877	2.1654
3	509.98	497.53	16.307	14.955	1.9832	2.1624
4	510.07	495.44	16.361	14.772	1.9769	2.1605
5	509.43	492.16	16.291	14.439	1.9851	2.2398

EQUIVALENT INLET PRESSURE (DEG. R)

STREAM LINE	EQUIVALENT INLET PRESSURE (PSI)	EQUIVALENT INLET TEMPERATURE (DEG. R)
1	21.890	548.55
2	22.460	551.73
3	23.090	555.41
4	23.979	560.50
5	24.864	565.62



SET NUMBER	PAGE NUMBER	KPM	TOTAL/STATIC PRESSURE RATIO	INLET TOTAL PRESSURE (PSI)	INLET TOTAL TEMPERATURE (DEG. R)
1	3	20000.0	2.200	32.340	603.60

OVERALL TURBINE CHARACTERISTICS

STREAM LINE	PRESSURE RATIO TOT/STA	EFFICIENCY TOT/TOT	HEAD COEFFICIENT	BLADE/JET SPEED RATIO	THEORETICAL DEGREE OF REACTION
1	2.4163	.0587	2.0014	.3779	.3208
2	2.1235	.0677	5.2402	.4373	.3150
3	1.9832	.0642	4.6118	.4657	.3814
4	1.8786	.0759	4.0543	.4266	.4660
5	1.9851	.0770	3.7248	.5181	.5368

MASS AVERAGED QUANTITIES

HORSE POWER = 136.30 (HP)  
 MOMENTUM FLOW RATE = 35.29 (FT-LB) (LB/SEC)

REFERRED RPM = 18534.80 (HP)  
 REFERRED HORSE POWER = 57.42 (FT-LB) (LB/SEC)  
 REFERRED MOMENTUM FLOW RATE = 16.27 (FT-LB) (LB/SEC)

TOTAL/STATIC EFFICIENCY = .7722  
 TOTAL/STATIC EFFICIENCY = .8716  
 TOTAL/STATIC PRESSURE RATIO = 2.2137  
 TOTAL/STATIC PRESSURE RATIO = 2.0005

HEAD COEFFICIENT = 4.8149  
 BLADE/JET SPEED RATIO = .4557  
 THEORETICAL DEGREE OF REACTION = .3978  
 MACH NUMBER AT STATION 0 = .2082



SET PAGE RPM  
 NUMBER 1 25000.0  
 IDIAL/STATIC PRESSURE 32.340  
 INLET TOTAL TEMPERATURE 603.60  
 PRESSURE RATIO 2.200  
 INLET TOTAL TEMPERATURE 603.60

STATOR EXIT SOLUTION

STREAM LINE	RADIAL POSITION (IN)	X=R/RM	RADIAL SHFT (IN)	BLADE OPENING (IN)	Y=VA/VAM	EFFICIENCY	BLADE COEFFICIENT	LOSS	CONTINUITY	Z/LIA*	FLOW RATE FRACTION
1	2.763	.865	0.0000	.2126	1.1029	.9153	.0847	.0847	.0847	.0847	0.0000
2	3.093	.940	0.0000	.2147	1.0474	.9115	.0895	.0895	.0895	.0895	.2543
3	3.412	1.024	0.0000	.2225	1.0000	.9094	.0916	.0916	.0916	.0916	.4741
4	3.627	1.074	0.0000	.2345	.9399	.9067	.0933	.0933	.0933	.0933	.7575
5		1.135	0.0000	.2926	.8903	.9053	.0947	.0947	.0947	.0947	1.0000

ABSOLUTE VELOCITY (FPS)

STREAM LINE	AXIAL COMPONENT	RADIAL COMPONENT	TANGENTIAL COMPONENT	OVERALL VELOCITY	AXIAL COMPONENT	RADIAL COMPONENT	TANGENTIAL COMPONENT	OVERALL VELOCITY	WHEEL VELOCITY
1	403.36	-16.18	891.04	978.22	403.36	-16.18	288.03	495.90	603.03
2	383.07	3.64	836.81	920.33	383.07	3.64	181.64	423.97	615.17
3	365.73	8.37	791.85	872.27	365.73	8.37	94.70	372.89	697.15
4	343.77	29.86	738.33	814.99	343.77	29.86	-10.34	345.22	748.67
5	325.61	38.63	694.71	768.20	325.61	38.63	-96.58	341.82	791.29

MACH NUMBER FLOW ANGLE (DEG. R)

STREAM LINE	ABSOLUTE	RELATIVE	ABSOLUTE	RELATIVE	TOTAL	STATIC	TEMPERATURE (DEG. R)
1	.87	.44	65.65	35.53	603.60	527.97	30.776
2	.81	.37	65.41	25.37	603.60	533.12	30.910
3	.77	.33	65.21	14.52	603.60	540.22	31.023
4	.71	.30	65.04	-1.72	603.60	548.33	31.181
5	.67	.30	64.89	-16.52	603.60	554.49	31.303

TEMPERATURE (DEG. R) PRESSURE (PSI)

STREAM LINE	TOT/TOT	STATIC	PRESSURE RATIO
1	1.0504	18.757	1.7244
2	1.0463	20.015	1.6158
3	1.0433	21.050	1.5344
4	1.0372	22.880	1.4515
5	1.0331	23.260	1.3904





SET NUMBER    KAGE NUMBER    RPM    TOTAL/STATIC PRESSURE RATIO    INLET TOTAL PRESSURE (PSI)    INLET TEMPERATURE (DEG. R)    TOTAL INLET TEMPERATURE (DEG. R)

1            2            25000.0            2.200            32.340            603.60

ROTOR EXIT SOLUTION

STREAM LINE	RADIAL POSITION	X=R/RM	RADIAL SHIFT	BLADE OPENING	BLADE EFFICIENCY	Y=VA /VAM	LOSS COEFFICIENT	ZETA* CONTINUITY	FLUO RATE FRACTION
1	3.693	.925	.0710	.1912	.9031	.9947	.0269	.0969	0.0000
2	3.320	.925	-.0168	.2216	.9138	.9138	.0951	.0951	.2227
3	3.362	1.000	-.0495	.2547	.9062	1.0000	.0938	.0938	.4165
4	3.582	1.078	-.1537	.2747	.8981	1.1508	.1019	.1019	.7149
5	3.837	1.175	-.2100	.2983	.8918	1.2961	.1083	.1083	1.0000

ABSOLUTE VELOCITY (FPS)

STREAM LINE	AXIAL COMPONENT	RADIAL COMPONENT	TANGENTIAL COMPONENT	OVERALL VELOCITY	AXIAL COMPONENT	RADIAL COMPONENT	TANGENTIAL COMPONENT	OVERALL VELOCITY	WHEEL VELOCITY
1	331.43	-13.29	-210.08	392.63	331.43	-13.29	-797.60	863.82	587.52
2	304.47	2.89	-40.56	307.17	304.47	2.89	-699.40	762.81	758.64
3	333.18	7.62	-27.51	334.41	333.18	7.62	-739.83	811.43	712.51
4	383.43	33.30	-19.55	385.37	383.43	33.30	-801.76	809.36	782.31
5	431.85	51.24	-25.64	435.64	431.85	51.24	-862.75	966.15	937.11

205

MACH NUMBER    FLOW ANGLE (DEG)

STREAM LINE	ABSOLUTE	RELATIVE	ABSOLUTE	RELATIVE	TEMPERATURE (DEG. R)	PRESSURE (PSI)	PRESSURE RATIO
1	.37	.80	-32.37	-67.44	493.64	14.428	2.2307
2	.28	.70	-7.59	-66.48	507.91	16.300	1.9881
3	.31	.74	-4.72	-65.76	508.47	16.353	1.9776
4	.35	.81	-2.92	-64.45	509.06	16.290	1.9659
5	.40	.89	-3.40	-63.41	508.54	16.059	2.0138

EQUIV/STATIC PRESSURE RATIO

STREAM LINE	EQUIVALENT TEMPERATURE (DEG. R)	EQUIVALENT INLET PRESSURE (PSI)	EQUIV/STATIC PRESSURE RATIO
1	542.90	21.238	1.6
2	548.48	22.107	1.4
3	553.95	23.972	1.5
4	562.52	24.364	1.6
5	570.42	25.684	1.8



SET NUMBER	PAGE NUMBER	KPM	TOTAL/STATIC PRESSURE RATIO	INLET TOTAL PRESSURE (PSI)	INLET TOTAL TEMPERATURE (DEG. R)
1	3	25000.0	2.200	32.340	603.60

OVERALL TURBINE CHARACTERISTICS

STREAM LINE	PRESSURE RATIO TOT/STA	TOT/STA	EFFICIENCY TOT/TOT	HEAD COEFFICIENT	SPEED/RATE	BLADE/JET	THEORETICAL
1	2.4460	.8079	.8973	4.4985	4715	.5609	.3609
2	2.0953	.8122	.8917	3.3191	5574	.3275	.3275
3	2.1093	.8266	.8904	2.8666	5906	.3989	.3989
4	2.1635	.7716	.8603	2.5807	6249	.4096	.4096
5	2.2488	.7620	.8680	2.3944	6462	.5652	.5652

MASS AVERAGED QUANTITIES

HORSE POWER =	137.41	(HP)
MOMENT FLOW RATE =	29.87	(FT-LB)
	4.18	(LB/SEC)

REFERRED RPM =	23168.50	(HP)
REFERRED HORSE POWER =	57.88	(HP)
REFERRED MOMENT FLOW RATE =	13.12	(FT-LB)
	2.05	(LB/SEC)

TOTAL/STATIC EFFICIENCY =	.8073
TOTAL/STATIC PRESSURE RATIO =	.8854
	2.1720

HEAD COEFFICIENT RATIO =	3.0232
BLADE/JET SPEED =	.5251
THEORETICAL DEGREE OF REACTION =	.4198
MACH NUMBER AT STATION 0 =	.2047



SET PAGE TOTAL/STATIC INLET TOTAL INLET TOTAL  
 NUMBER NUMBER 1 30000.0 RPM PRESSURE RATIO PRESSURE TEMPERATURE TEMPERATURE  
 1 1 2.200 32.340 603.60 603.60

STATOR EXIT SOLUTION

STREAM LINE	RADIAL POSITION (IN)	X=R/RM	RADIAL SHIFT (IN)	BLADE OPENING (IN)	Y=VA./VAM	WAVE EFFICIENCY	LOSS COEFFICIENT	ZETA* CONTINUITY	FLOW RATE FRACTION
1	2.764	.865	0.0000	.2126	1.1037	.9179	.0021	.0021	0.0000
2	3.003	.940	0.0000	.2247	1.0477	.9136	.0064	.0064	.2545
3	3.195	1.000	0.0290	.2576	1.0000	.9102	.0098	.0098	.4743
4	3.432	1.074	0.0000	.2745	.9396	.9081	.0919	.0919	.7577
5	3.627	1.135	0.0000	.2926	.8898	.9065	.0935	.0935	1.0000

ABSOLUTE VELOCITY (FPS)

RELATIVE VELOCITY (FPS)

STREAM LINE	AXIAL COMPONENT	RADIAL COMPONENT	TANGENTIAL COMPONENT	OVERALL VELOCITY	AXIAL COMPONENT	RADIAL COMPONENT	TANGENTIAL COMPONENT	OVERALL VELOCITY	WHEEL VELOCITY
1	403.41	-16.18	891.15	978.34	403.41	-16.18	167.54	437.11	723.62
2	382.94	3.64	836.55	920.04	382.94	3.64	50.34	386.25	786.21
3	370.16	8.36	791.33	871.70	370.16	8.36	-45.25	373.01	836.58
4	343.44	29.83	737.61	814.19	343.44	29.83	-160.80	300.39	898.41
5	325.22	38.58	693.87	767.27	325.22	38.58	-255.68	415.48	949.55

MACH NUMBER FLOW ANGLE (DEG)

TEMPERATURE (DEG. R)

PRESSURE (PSI)

STREAM LINE	ABSOLUTE	RELATIVE	ABSOLUTE	RELATIVE	TOTAL	STATIC	TOTAL	STATIC	10T/10T	10I/51A
1	.87	.39	65.65	22.55	603.60	523.95	30.828	18.787	1.0490	1.7214
2	.81	.34	65.41	7.49	603.60	533.16	30.948	20.046	1.0450	1.6143
3	.76	.33	65.21	-6.97	603.60	540.37	31.052	21.003	1.0415	1.5191
4	.71	.33	65.04	-25.09	603.60	548.44	31.203	22.331	1.0364	1.4065
5	.66	.36	64.89	-38.18	603.60	554.61	31.320	23.290	1.0325	1.3006



SET NUMBER PAGE RPM TOTAL/STATIC PRESSURE INLET TOTAL INLET TOTAL  
 NUMBER NUMBER PRESSURE (PSI) TEMPERATURE (DEG. R) TEMPERATURE (DEG. R)  
 1 2 30000.0 2.200 32.340 603.60

KOTOR EXIT SOLUTION

STREAM LINE	RADIAL POSITION	X=R/RM	RADIAL SHIFT	BI ANGLE	Y=VA /VAM	EFFICIENCY	FLANE	LOSS COEFFICIENT	CONTINITY*	FLOW RATE
1	2.693	.825	.0710	.1912	1.0024	.9152	.0849	.0849	.0849	0.0000
2	3.020	.925	-.0168	.2218	.8883	.8969	.1032	.1032	.1032	.2166
3	3.265	1.000	-.0405	.2447	1.0000	.8931	.1169	.1169	.1169	.4058
4	3.585	1.098	-.1537	.2747	1.1837	.8931	.1069	.1069	.1069	.7051
5	3.837	1.175	-.2100	.2983	1.3551	.9010	.0991	.0991	.0991	1.0000

ABSOLUTE VELOCITY (FPS)

STREAM LINE	AXIAL COMPONENT	RADIAL COMPONENT	TANGENTIAL COMPONENT	OVERALL VELOCITY	AXIAL COMPONENT	RADIAL COMPONENT	TANGENTIAL COMPONENT	OVERALL VELOCITY	WHEEL VELOCITY
1	331.81	-13.31	-93.49	344.99	331.81	-13.31	-798.52	864.82	705.03
2	294.05	2.29	115.13	315.80	294.05	2.29	-675.48	736.72	790.41
3	331.02	7.57	119.75	352.10	331.02	7.57	-735.03	808.16	854.78
4	391.84	34.03	119.51	411.01	391.84	34.03	-615.34	808.65	938.65
5	448.58	53.22	108.37	464.54	448.58	53.22	-896.16	1003.57	1004.53

MACH NUMBER

FLOW ANGLE (DEG)

TEMPERATURE (DEG. R)

PRESSURE (PSI)

STATIC

STREAM LINE	ABSOLUTE	RELATIVE	ABSOLUTE	RELATIVE	TOTAL	STATIC	TOTAL	STATIC	101/101	101/STA
1	.32	.81	-15.74	-67.44	485.31	475.41	13.767	12.800	2.1451	2.5249
2	.32	.74	-21.38	-66.48	509.29	500.99	16.467	16.345	1.9682	2.0805
3	.38	.74	19.89	-65.70	510.47	500.43	16.422	15.300	1.6673	2.1109
4	.43	.83	16.94	-64.45	511.95	497.90	16.541	15.005	1.9552	2.1553
5	.43	.92	13.58	-63.41	512.07	494.11	16.490	14.553	1.9612	2.2252

STREAM LINE	EQUIVALENT TEMPERATURE (DEG. R)	EQUIVALENT PRESSURE (PSI)	EQUIV/STATIC PRESSURE RATIO
1	537.64	20.561	1.5
2	546.16	21.808	1.4
3	554.51	23.075	1.5
4	562.63	25.011	1.7
5	577.92	26.899	1.8





SET NUMBER	PAGE NUMBER	RPM	TOTAL/STATIC PRESSURE RATIO	INLET TOTAL PRESSURE (PSI)	INLET TOTAL TEMPERATURE (DEG. R)
1	3	30000.0	2.200	32.340	603.60

OVERALL TURBINE CHARACTERISTICS

STREAM LINE	PRESSURE RATIO TOT/STA	EFFICIENCY TOT/TOT	HEAD COEFFICIENT	BLADE/JET SPEED RATIO	THEORETICAL DEGREE OF REACTION
1	2.5249	.8429	3.2209	.5572	.3617
2	2.0805	.8573	2.8162	.6717	.3237
3	2.1107	.8766	1.5922	.7085	.4012
4	2.1553	.8710	1.7704	.7516	.4892
5	2.2222	.8663	1.6410	.7806	.5611

MASS AVERAGED QUANTITIES

HORSE POWER =	136.86 (HP)
MOMENT FLOW RATE =	23.96 (FT-LB)
	4.22 (LB/SEC)
REFERRED RPM	27802.20
REFERRED HORSE POWER =	57.65 (HP)
REFERRED MOMENT FLOW RATE =	10.89 (FT-LB)
	2.07 (LB/SEC)

TOTAL/STATIC EFFICIENCY =	.7905
TOTAL/STATIC PRESSURE RATIO =	.8810
TOTAL/STATIC PRESSURE RATIO =	2.1801
TOTAL/STATIC PRESSURE RATIO =	2.0110

HEAD COEFFICIENT	=	2.1024
BLADE/JET SPEED RATIO	=	.6897
THEORETICAL DEGREE OF REACTION	=	.4214
MACH NUMBER AT STATION 0	=	.2068



SET CASE RPM TOTAL/STATIC INLET TOTAL INLET TOTAL  
 NUMBER NUMBER 10000.0 PRESSURE RATIO PRESSURE TEMPERATURE TEMPERATURE  
 1 1 2.400 35.280 615.30

STATOR EXIT SOLUTION

STREAM LINE	RADIAL POSITION (IN)	X=R/RM	RADIAL SHIFT (IN)	BLADE OPENING (IN)	BLADE EFFICIENCY	Y=VA /VAM	LOSS COEFFICIENT	ZETA*	CONTINUITY	FLOW RATE FRACTION
1	2.764	.865	0.0000	.2126	.9195	1.1059	.0805	.0805	0.0000	
2	3.003	.940	0.0000	.2347	.9125	1.0486	.0875	.0875	.2499	
3	3.135	1.000	0.0000	.2526	.9068	1.0000	.0932	.0932	.4680	
4	3.432	1.074	0.0000	.2745	.9015	.9387	.0985	.0985	.7531	
5	3.627	1.135	0.0000	.2926	.8972	.8883	.1028	.1028	1.0000	

STREAM LINE	ABSOLUTE VELOCITY (FPS)					RELATIVE VELOCITY (FPS)				
	AXIAL COMPONENT	RADIAL COMPONENT	TANGENTIAL COMPONENT	OVERALL VELOCITY	AXIAL COMPONENT	RADIAL COMPONENT	TANGENTIAL COMPONENT	OVERALL VELOCITY	WHEEL VELOCITY	
1	473.88	-19.01	1046.83	1149.25	473.88	-19.01	805.62	934.85	241.21	
2	449.34	4.27	981.58	1079.55	449.34	4.27	719.52	848.31	262.07	
3	428.49	9.80	927.73	1021.95	428.49	9.80	648.87	772.65	278.86	
4	402.24	34.94	863.90	953.59	402.24	34.94	564.43	693.97	299.47	
5	380.61	45.16	812.06	897.97	380.61	45.16	495.54	626.47	316.52	

STREAM LINE	MACH NUMBER			TEMPERATURE (DEG. R)			PRESSURE (PSI)		
	ABSOLUTE	RELATIVE	FLOW ANGLE (DEG)	ABSOLUTE	RELATIVE	TEMPERATURE (DEG. R)	TOTAL	STATIC	PRESSURE RATIO
1	1.04	.85	59.54	615.30	505.40	32.985	16.566	1.0496	2.1296
2	.97	.76	58.02	615.30	518.32	33.133	18.107	1.0674	1.8449
3	.91	.69	56.56	615.30	528.59	33.236	19.406	1.0817	1.6017
4	.84	.61	54.53	615.30	539.83	33.298	21.116	1.0955	1.3788
5	.78	.55	52.48	615.30	548.20	33.578	22.416	1.0507	1.15739



SET PAGE RPM TOTAL/STATIC INLET TOTAL INLET TOTAL  
 NUMBER NUMBER PRESSURE RATIO PRESSURE (PSI) TEMPERATURE (DEC. R) TEMPERATURE (DEC. R)

1 2 10000.0 2.400 35.280 615.30

ROTOR EXIT SOLUTION

STREAM LINE	RADIAL POSITION	X=R/RM	RADIAL SHIFT	BLADE OPENING	Y=VA /VAM	EFFICIENCY	LOSS COEFFICIENT	CONTINUITY	ZETA*	FLOW RATE FRACTION
1	2.693	.825	.0710	.1912	.9754	.8379	.1621	.1621	.1621	0.0000
2	3.020	.925	-.0168	.2518	.9888	.8364	.1637	.1637	.1637	.2359
3	3.265	1.000	-.0405	.2447	1.0000	.8352	.1649	.1649	.1649	.4371
4	3.585	1.098	-.1537	.2747	1.0449	.8402	.1599	.1599	.1599	.7311
5	3.837	1.175	-.2100	.2983	1.1009	.8441	.1559	.1559	.1559	1.0000

RELATIVE VELOCITY (FPS)

STREAM LINE	AXIAL COMPONENT	RADIAL COMPONENT	TANGENTIAL COMPONENT	OVERALL VELOCITY	AXIAL COMPONENT	RADIAL COMPONENT	TANGENTIAL COMPONENT	OVERALL VELOCITY	WHEEL VELOCITY
1	376.07	-15.09	-670.01	768.48	376.07	-15.09	-670.01	980.16	235.01
2	381.24	3.62	-612.23	721.24	381.24	3.62	-612.23	955.16	267.54
3	385.57	8.82	-571.23	689.23	385.57	8.82	-571.23	939.07	299.93
4	402.88	34.99	-529.56	666.31	402.88	34.99	-529.56	936.47	312.88
5	424.47	50.36	-513.15	667.86	424.47	50.36	-513.15	949.63	334.84

MACH NUMBER FLOW ANGLE (DEC)

STREAM LINE	ABSOLUTE	RELATIVE	ABSOLUTE	RELATIVE	TEMPERATURE (DEC. R)	PRESSURE (PSI)	PRESSURE RATIO
1	.70	.90	-60.70	-67.44	TOTAL	TOTAL	TOT/TOT
2	.66	.87	-58.09	-66.48	547.07	497.93	1.6023
3	.63	.85	-55.99	-65.76	545.64	502.76	1.1054
4	.60	.85	-52.74	-65.45	545.16	505.73	1.8022
5	.61	.86	-50.41	-63.41	543.93	507.73	1.7950
					506.81	506.81	2.3561
					19.575	19.575	2.5779
					14.081	14.081	2.5828
					14.658	14.658	
					15.102	15.102	
					15.488	15.488	
					15.455	15.455	

EQUIVALENT INLET TEMPERATURE (DEC. R)

STREAM LINE	EQUIVALENT INLET TEMPERATURE (DEC. R)	EQUIV/STATIC PRESSURE RATIO
1	577.87	1.8
2	578.27	1.8
3	579.60	1.8
4	580.39	1.8
5	581.85	1.8



SET NUMBER	PAGE NUMBER	RPM	TOTAL/STATIC PRESSURE RATIO	INLET TOTAL PRESSURE (PSI)	INLET TOTAL TEMPERATURE (DEG. R)
1	3	10000.0	2.400	35.280	615.30

OVERALL TURBINE CHARACTERISTICS

STREAM LINE	PRESSURE RATIO TOT/STA	EFFICIENCY TOT/TOT	HEAD COEFFICIENT TOT/TOT	SPEED RATIO	THEORETICAL DEGREE OF REACTION
1	1.8023	.4804	.7159	.29.3338	.1584
2	2.4068	.5102	.7310	.23.8934	.2217
3	2.3361	.5296	.7406	.20.4693	.2764
4	2.2779	.5477	.7540	.17.2807	.3492
5	2.2628	.5522	.7620	.15.5053	.4214

MASS AVERAGED QUANTITIES

HORSE POWER =	309.48 (HP)
MOMENT FLOW RATE =	57.50 (FT-LB) (LR/SEC)
REFERRED RPM	9178.87 (HP)
REFERRED HORSE POWER =	41.87 (HP)
REFERRED MOMENT FLOW RATE =	23.76 (FT-LB) (LR/SEC)
REFERRED FLOW RATE =	2.09 (LR/SEC)

TOTAL/STATIC EFFICIENCY =	.5259
TOTAL/TOTAL EFFICIENCY =	.7413
TOTAL/STATIC PRESSURE RATIO =	3.5928

HEAD COEFFICIENT	=	21.9157
BLADE/JET SPEED RATIO	=	.2181
THEORETICAL DEGREE OF REACTION	=	.2843
MACH NUMBER AT STATION 0	=	.2084





SET NUMBER 1 PAGE 1 RPM 15000.0  
 TOTAL/STATIC PRESSURE RATIO 2.400  
 INLET TOTAL TEMPERATURE 615.30  
 PRESSURE 35.280

STATOR EXIT SOLUTION

STREAM LINE	RADIAL POSITION (IN)	X=R/RM	RADIAL SHIFTE (IN)	BLADE OPENING (IN)	BLADE EFFICIENCY	LOSS COEFFICIENT	Z/TAX CONTINUITY	FLOW RATE FRACTION
1	2.764	.865	0.0000	.2126	.9122	.0878	.0878	0.0000
2	3.003	.940	0.0000	.2347	.9056	.0944	.0944	.2515
3	3.195	1.000	0.0000	.2526	.9002	.0998	.0998	.4703
4	3.432	1.074	0.0000	.2745	.9000	.1000	.1000	.7546
5	3.627	1.135	0.0000	.2926	.8998	.1002	.1002	1.0000

RELATIVE VELOCITY (FPS)

STREAM LINE	AXIAL COMPONENT	RADIAL COMPONENT	TANGENTIAL COMPONENT	OVERALL VELOCITY	WAKE VELOCITY
1	439.59	-17.63	971.07	1066.08	361.81
2	417.04	3.96	911.03	1001.96	593.10
3	398.05	9.11	861.82	949.35	418.39
4	374.50	32.53	804.34	887.84	449.20
5	355.18	42.14	757.81	837.98	474.77

TEMPERATURE (DEG. R)

STREAM LINE	ABSOLUTE	RELATIVE	ABSOLUTE	RELATIVE	STATIC	TOTAL	STATIC	TOTAL	TOI/TOI	TOI/STA
1	.95	.67	65.65	54.19	520.73	615.30	53.169	48.496	1.0676	1.9075
2	.89	.52	65.41	51.16	531.29	615.30	33.299	19.982	1.0595	1.7656
3	.83	.45	65.21	48.10	540.30	615.30	33.417	21.203	1.0557	1.6539
4	.77	.45	65.04	43.48	549.71	615.30	33.670	22.693	1.0478	1.5597
5	.72	.39	64.89	38.55	556.87	615.30	33.858	23.877	1.0420	1.4775



SET NUMBER PAGE NUMBER RPM TOTAL/STATIC PRESSURE RATIO INLET TOTAL PRESSURE (PSI) INLET TOTAL TEMPERATURE (DEG. R) FLOW RATE FRACTION

1 2 15000.0 2.400 35.280 615.30 0.0000

ROTOR EX11 SOLUTION

STREAM LINE	RADIAL POSITION	X=R/RM	SHIFT	RADIAL OPENING	BLADE	Y=VA /VAM	EFFICIENCY	WAVE LOSS COEFFICIENT	ZETA* CONTINUITY	FLOW RATE FRACTION
1	2.693	.925	.0710	.1912	.1912	.9810	.8603	.1397	.1397	0.0000
2	3.020	.925	-.0169	.2219	.2219	.9666	.8647	.1354	.1354	.2320
3	3.262	1.000	-.0405	.2447	.2447	1.0000	.8679	.1321	.1321	.4312
4	3.585	1.029	-.1537	.2747	.2747	1.0753	.8781	.1239	.1239	.7262
5	3.837	1.175	-.2100	.2983	.2983	1.1567	.8825	.1175	.1175	1.0000

ABSOLUTE VELOCITY (FPS)

STREAM LINE	AXIAL COMPONENT	RADIAL COMPONENT	TANGENTIAL COMPONENT	OVERALL VELOCITY	AXIAL COMPONENT	RADIAL COMPONENT	TANGENTIAL COMPONENT	OVERALL VELOCITY	WHEEL VELOCITY
1	361.69	-14.51	-517.91	631.88	361.69	-14.51	-070.43	942.70	352.51
2	356.38	3.39	-423.34	553.39	356.38	3.39	-018.65	892.66	395.31
3	368.69	8.44	-391.28	537.69	368.69	8.44	-018.62	897.20	427.33
4	397.46	34.43	-359.70	536.42	397.46	34.43	-029.02	919.59	476.33
5	426.46	50.60	-349.72	553.83	426.46	50.60	-051.98	954.10	502.26

RELATIVE VELOCITY (FPS)

STREAM LINE	AXIAL COMPONENT	RADIAL COMPONENT	TANGENTIAL COMPONENT	OVERALL VELOCITY	AXIAL COMPONENT	RADIAL COMPONENT	TANGENTIAL COMPONENT	OVERALL VELOCITY	WHEEL VELOCITY
1	361.69	-14.51	-517.91	631.88	361.69	-14.51	-070.43	942.70	352.51
2	356.38	3.39	-423.34	553.39	356.38	3.39	-018.65	892.66	395.31
3	368.69	8.44	-391.28	537.69	368.69	8.44	-018.62	897.20	427.33
4	397.46	34.43	-359.70	536.42	397.46	34.43	-029.02	919.59	476.33
5	426.46	50.60	-349.72	553.83	426.46	50.60	-051.98	954.10	502.26

TEMPERATURE (DEG. R)

STREAM LINE	ABSOLUTE	RELATIVE	ABSOLUTE	RELATIVE	FLOW ANGLE (DEG)	TEMPERATURE (DEG. R)	PRESSURE RATIO
1	58	.87	-55.07	-67.44	58	101/101	101/514
2	50	.81	-49.91	-66.48	50	STATIC	2.5144
3	49	.82	-46.71	-65.76	49	TOTAL	2.3479
4	49	.04	-42.22	-64.45	49	STATIC	2.2096
5	50	.87	-39.36	-63.41	50	TOTAL	2.0739
						STATIC	2.3024

EQUIVALENT INLET PRESSURE (PSI)

STREAM LINE	EQUIVALENT INLET PRESSURE (PSI)	EQUIV/STATIC PRESSURE RATIO
1	24.942	1.8
2	25.277	1.7
3	25.649	1.7
4	26.321	1.7
5	26.942	1.8



SET NUMBER	RPM	JOIAL/STATIC PRESSURE RATIO	INLET TOTAL PRESSURE (PSI)	INLET TEMPERATURE (DEG. R)
1	15000.0	2.400	35.280	615.30

OVERALL TURBINE CHARACTERISTICS

STREAM LINE	PRESSURE RATIO TOT/STG	EFFICIENCY TOT/IDT	HEAD COEFFICIENT	SPEED RATIO	DEGREE OF REACTION
1	2.5144	.8031	13.0014	.3765	.2725
2	2.3179	.8181	18.2106	.3359	.3978
3	2.2896	.8249	8.9087	.3351	.3576
4	2.2729	.8363	7.6624	.3613	.4335
5	2.5024	.8428	6.9546	.3792	.5022

MASS AVERAGED QUANTITIES

HORSE POWER = 135.97 (HP)  
 MOMENT = 47.61 (FT-LB)  
 FLOW RATE = 4.54 (LB/SEC)

REFERRED RPM = 13768.78 (HP)  
 REFERRED HORSE POWER = 52.00 (HP)  
 REFERRED MOMENT = 39.84 (FT-LB)  
 REFERRED FLOW RATE = 2.06 (LB/SEC)

TOTAL/STATIC EFFICIENCY = .6705  
 TOTAL/STATIC EFFICIENCY = .8257  
 TOTAL/STATIC PRESSURE RATIO = 3.3484

HEAD COEFFICIENT = 9.2497  
 BLADE/JET SPEED RATIO = .3297  
 THEORETICAL DEGREE OF REACTION = .3691  
 MACH NUMBER AT STATION 0 = .2057



SET NUMBER 1  
 RPM 20000.0  
 IRIAL/STATIC PRESSURE RATIO 2.400  
 IRIAL TOTAL TEMPERATURE 615.30  
 PRESSURE 35.200

STATOR EXIT SOLUTION

STREAM LINE	RADIAL POSITION (IN)	X=R/RM	RADIAL SHIFIT (IN)	BLADE OPENING (IN)	Y=VA /VAM	EFFICIENCY	FLADE COEFFICIENT	LOSS COEFFICIENT	Z/TAXX	CONTINUTY	FLOW RATE FRACTION
1	2.264	.865	0.0000	.2126	1.1017	.9133	.0067	.0067	.0867	0.0000	
2	3.003	.940	0.0000	.347	1.0370	.9104	.0096	.0096	.0896	.3520	
3	3.195	1.000	0.0000	.5526	1.0000	.9000	.0920	.0920	.0920	.4715	
4	3.432	1.074	0.0000	.7745	.9401	.9061	.0939	.0939	.0939	.7556	
5	3.627	1.135	0.0000	.9926	.8905	.9045	.0955	.0955	.0955	1.0000	

RELATIVE VELOCITY (FPS)

STREAM LINE	AXIAL COMPONENT	RADIAL COMPONENT	TANGENTIAL COMPONENT	OVERALL VELOCITY	AXIAL COMPONENT	RADIAL COMPONENT	TANGENTIAL COMPONENT	OVERALL VELOCITY	WHIFT VELOCITY
1	429.69	-17.24	749.20	1042.07	429.69	-17.24	466.79	634.69	482.41
2	408.34	3.88	692.02	981.05	408.34	3.88	367.88	542.63	524.34
3	394.02	8.92	844.44	930.20	394.02	8.92	286.72	404.36	557.72
4	366.68	31.85	787.54	869.30	366.68	31.85	108.68	413.57	598.94
5	347.33	41.21	741.05	819.45	347.33	41.21	108.02	366.07	633.03

MACH NUMBER FLOW ANGLE (DEG. R)

STREAM LINE	ABSOLUTE	RELATIVE	ABSOLUTE	RELATIVE	TOTAL	STATIC	TOTAL	STATIC
1	.93	.57	65.65	47.37	615.30	524.54	37.403	19.101
2	.87	.48	65.41	42.02	615.30	535.24	33.494	20.559
3	.81	.42	65.21	36.33	615.30	543.50	33.649	21.787
4	.75	.36	65.04	27.22	615.30	552.42	33.845	23.207
5	.71	.32	64.89	17.28	615.30	559.42	33.996	24.362

TEMPERATURE (DEG. R) PRESSURE (PSI)

STREAM LINE	ABSOLUTE	RELATIVE	TOTAL	STATIC	TOTAL	STATIC	TOTAL	STATIC
1	100701	100701	100701	100701	100701	100701	100701	100701
2	100701	100701	100701	100701	100701	100701	100701	100701
3	100701	100701	100701	100701	100701	100701	100701	100701
4	100701	100701	100701	100701	100701	100701	100701	100701
5	100701	100701	100701	100701	100701	100701	100701	100701





SET PAGE RPM TOTAL/STATIC INLET TOTAL INLET TOTAL  
 NUMBER NUMBER PRESSURE RATIO PRESSURE (PSI) TEMPERATURE (DEG. R) TEMPERATURE (DEG. R)

1 2 20000.0 2.400 35.200 615.30

KOTOR EXIT SOLUTION

STREAM LINE	RADIAL POSITION	X=R/RH	RADIAL SHIFT	BLADE OPENING	Y=VA /VAM	EFFICIENCY	BLADE LOSS COEFFICIENT	ZETA*	CONTRIBUTION	FLOW RATE FRACTION
1	2.693	.825	-.0710	.1912	.9055	.8080	.1112	.1112	.1112	0.0000
2	3.020	.925	-.0168	.2218	.9479	.8929	.1071	.1071	.1071	.2279
3	3.265	1.000	-.0405	.2447	1.0000	.8960	.1040	.1040	.1040	.4256
4	3.585	1.098	-.1537	.2747	1.1024	.9031	.0970	.0970	.0970	.7221
5	3.837	1.175	-.2100	.2983	1.2069	.9086	.0914	.0914	.0914	1.0000

ABSOLUTE VELOCITY (FPS)

RELATIVE VELOCITY (FPS)

STREAM LINE	AXIAL COMPONENT	RADIAL COMPONENT	TANGENTIAL COMPONENT	OVERALL VELOCITY	AXIAL COMPONENT	RADIAL COMPONENT	TANGENTIAL COMPONENT	OVERALL VELOCITY	WHEEL VELOCITY
1	371.69	-14.91	-424.45	564.39	371.69	-14.91	-424.47	560.74	470.02
2	357.52	3.40	-294.20	463.02	357.52	3.40	-294.20	495.73	527.07
3	377.17	8.63	-267.65	462.57	377.17	8.63	-267.50	518.55	562.85
4	415.78	36.11	-243.64	403.26	415.78	36.11	-269.41	564.39	625.77
5	455.20	54.01	-239.71	517.29	455.20	54.01	-290.39	1018.39	669.68

MACH NUMBER

FLOW ANGLE (DEG)

TEMPERATURE (DEG. R)

PRESSURE RATIO

STREAM LINE	ABSOLUTE	RELATIVE	ABSOLUTE	RELATIVE	TOTAL	STATIC	TOTAL	STATIC	101/101	101/51A
1	.53	.90	-48.80	-67.44	505.89	479.39	15.616	12.935	2.2552	2.7274
2	.43	.82	-39.45	-66.48	511.68	493.84	16.589	14.651	2.1260	2.4600
3	.42	.84	-35.36	-65.76	511.54	493.73	16.632	14.692	2.1312	2.4012
4	.44	.89	-30.37	-64.45	511.41	491.99	16.693	14.576	2.1135	2.4264
5	.48	.94	-27.77	-63.41	510.51	488.25	16.810	14.209	2.1241	2.4829

EQUIVALENT INLET TEMPERATURE (DEG. R)

EQUIVALENT INLET PRESSURE (PSI)

EQUIV/STATIC PRESSURE RATIO

1	557.48	23.576	1.8
2	560.61	24.100	1.7
3	561.94	24.802	1.7
4	568.79	25.799	1.6
5	574.55	26.746	1.5



SET NUMBER PAGE NUMBER RPM TOTAL/STATIC PRESSURE RATIO INLET TOTAL PRESSURE (PSI) INLET TOTAL TEMPERATURE (DEG. R) JET TOTAL TEMPERATURE (DEG. R)

1 3 20000.0 2.400 35.280 615.30

OVERALL TURBINE CHARACTERISTICS

STREAM LINE	PRESSURE RATIO TOT/STA	EFFICIENCY TOT/STA	HEAD COEFFICIENT TOT/TOF	BLADE/JET SPEED RATIO	THEORETICAL DEGREE OF REACTION
1	2.7274	.8560	2.2191	.3554	.3548
2	2.4060	.8584	5.2763	.4091	.3561
3	2.4043	.8716	5.2634	.4359	.4179
4	2.4234	.8770	4.6002	.4662	.4946
5	2.4829	.8795	4.2221	.4867	.5612

MASS AVERAGED QUANTITIES

HORSE POWER = 163.10 (HP)  
 MOMENTUM FLOW RATE = 42.31 (LBS/SEC)

REFERRED RPM = 18357.73 (RPM)  
 REFERRED HORSE POWER = 61.61 (HP)  
 REFERRED MOMENTUM FLOW RATE = 17.63 (LBS/SEC)

TOTAL/STATIC EFFICIENCY = .8713  
 TOTAL/STATIC PRESSURE RATIO = 2.4582

HEAD COEFFICIENT = 5.4279  
 THEORETICAL DEGREE OF REACTION = .4317  
 MACH NUMBER AT STATION 0 = .2055



SET CASE RPM TOTAL/STATIC INLET TOTAL INLET TOTAL  
 NUMBER NUMBER 30000.0 PRESSURE RATIO PRESSURE PRESSURE TEMPERATURE TEMPERATURE  
 1 1 2.400 35.280 615.30

STATOR EXIT SOLUTION

STREAM LINE	RADIAL POSITION (IN)	X=R/RM	SHIFT (IN)	RADIAL OPENING (IN)	BLADE EFFICIENCY	Y=VA /VAM	LOSS COEFFICIENT	CONTINUITY	WETTED AREA	FLOW RATE FRACTION
1	2.764	.865	0.0000	.2126	1.0000	1.0040	.0806	.0006	0.0000	0.0000
2	3.003	.940	0.0000	.2327	1.0000	1.0079	.0851	.0851	.2530	.2530
3	3.195	1.000	0.0000	.2528	1.0000	1.0079	.0807	.0807	.4734	.4734
4	3.432	1.074	0.0000	.2729	1.0000	1.0090	.0910	.0910	.7571	.7571
5	3.627	1.135	0.0000	.2926	1.0000	1.0095	.0929	.0929	1.0000	1.0000

ABSOLUTE VELOCITY (FPS) RELATIVE VELOCITY (FPS)

STREAM LINE	AXIAL COMPONENT	RADIAL COMPONENT	TANGENTIAL COMPONENT	OVERALL VELOCITY	AXIAL COMPONENT	RADIAL COMPONENT	TANGENTIAL COMPONENT	OVERALL VELOCITY	WHEEL VELOCITY
1	416.68	-16.71	920.47	1010.53	416.68	-16.71	196.86	461.15	723.62
2	395.49	3.76	863.95	950.17	395.49	3.76	77.74	403.07	786.23
3	377.42	8.64	817.15	900.14	377.42	8.64	-19.43	378.02	836.58
4	354.58	30.80	781.55	840.67	354.58	30.80	-136.86	381.32	898.41
5	335.72	39.83	716.29	792.06	335.72	39.83	-233.26	410.74	949.55

MACH NUMBER FLOW ANGLE (DEG. R) TEMPERATURE (PSI)

STREAM LINE	ABSOLUTE	RELATIVE	RELATIVE	ABSOLUTE	RELATIVE	TOTAL	STATIC	STATIC	TOTAL	STATIC	TOT/TOT	TOT/STA
1	.90	.41	25.29	65.65	65.30	615.30	530.33	530.33	33.575	19.958	1.0508	1.7677
2	.78	.33	11.12	65.41	65.30	615.30	540.17	540.17	33.708	21.370	1.0466	1.6509
3	.73	.33	-2.95	65.21	65.30	615.30	547.08	547.08	33.822	22.532	1.0431	1.5650
4	.68	.33	-21.11	65.04	65.30	615.30	556.50	556.50	33.921	23.816	1.0479	1.4752
5	.68	.35	-34.79	64.89	65.30	615.30	563.10	563.10	34.122	25.019	1.0339	1.4101



SET PAGE RPM TOTAL/STATIC INLET TOTAL  
 NUMBER NUMBER PRESSURE RATIO PRESSURE INLET TOTAL  
 1 2 30000.0 2.400 35.280 615.30  
 (PSI) (DEG. R)

ROTOR EXIT SOLUTION

STREAM LINE	RADIAL POSITION	X=R/RM	RADIAL SHIFT	BLADE OPENING	BLADE EFFICIENCY	Y=VA /VAH	LOSS COEFFICIENT	ZETA* CONTINUITY	FLUX RATE FRACTION
1	2.693	.825	.0710	.1912	.9163	1.0001	.0837	.0837	0.0000
2	3.020	.925	-.0168	.2218	.8969	.8969	.1012	.1012	.2180
3	3.265	1.000	-.0405	.2447	.8858	1.0000	.1142	.1142	.4086
4	3.585	1.098	-.1537	.2747	.8982	1.1731	.1018	.1018	.7074
5	3.837	1.175	-.2100	.2983	.9080	1.3365	.0920	.0920	1.0000

RELATIVE VELOCITY (FPS)

STREAM LINE	AXIAL COMPONENT	RADIAL COMPONENT	TANGENTIAL COMPONENT	OVERALL VELOCITY	AXIAL COMPONENT	RADIAL COMPONENT	TANGENTIAL COMPONENT	OVERALL VELOCITY	WHEEL VELOCITY
1	351.32	-14.09	-140.43	378.60	351.32	-14.09	-845.45	915.65	705.03
2	315.07	2.99	66.87	322.10	315.07	2.99	-723.75	789.36	720.61
3	312.28	8.04	74.77	359.24	312.28	8.04	-700.01	855.50	854.78
4	412.09	35.79	76.97	420.74	412.09	35.79	-661.69	955.82	938.25
5	469.47	55.70	66.63	477.43	469.47	55.70	-937.90	1050.51	1004.53

MACH NUMBER FLOW ANGLE (DEG)

STREAM LINE	ABSOLUTE	RELATIVE	ABSOLUTE	RELATIVE	TEMPERATURE (DEG. R)	PRESSURE (PSI)	100/TOT	100/STA
1	35	.86	-21.79	-67.44	487.97	476.05	14.227	14.047
2	39	.72	11.98	-66.48	511.06	502.43	15.097	15.919
3	33	.78	12.02	-65.76	512.17	501.43	16.840	15.636
4	38	.87	10.58	-64.45	513.46	498.73	16.976	15.332
5	44	.96	8.08	-63.41	513.25	494.28	16.923	14.833

EQUIVALENT INLET PRESSURE (PSI) EQUIVALENT PRESSURE RATIO

1	245.81	23.073	1.7
2	254.27	23.306	1.5
3	262.53	24.681	1.9
4	274.75	26.971	1.9
5	286.07	28.778	1.9





SET NUMBER	PAGE NUMBER	RPM	TOTAL/STATIC PRESSURE RATIO	INLET TOTAL PRESSURE (PSI)	INLET TOTAL TEMPERATURE (DEG. R)
1	3	30000.0	2.400	35.280	615.30

OVERALL TURBINE CHARACTERISTICS

STREAM LINE	PRESSURE RATIO TOT/STG	EFFICIENCY TOT/TOT	HEAD COEFFICIENT	BLADE/JET SPEED RATIO	THEORETICAL DEGREE OF REACTION
1	2.7041	.8955	3.4336	.5350	.5928
2	2.2162	.8932	2.4320	.6411	.3438
3	2.0969	.8900	2.3916	.6755	.4203
4	2.5011	.8726	1.9410	.7178	.5030
5	2.3784	.7564	1.7983	.7457	.5735

MASS AVERAGED QUANTITIES

HORSE POWER =	161.72 (HP)
MOMENT FLOW RATE =	28.22 (FT-LB) (LB/SEC)

REFERRED RPM =	27536.60 (HP)
REFERRED HORSE-POWER =	61.97 (FT-LB) (LB/SEC)
REFERRED MOMENT FLOW RATE =	11.80 (FT-LB) (LB/SEC)
REFERRED FLOW RATE =	2.05 (LB/SEC)

TOTAL/STATIC EFFICIENCY =	.8047
TOTAL/TOTAL EFFICIENCY =	.8854
TOTAL/STATIC PRESSURE RATIO =	2.3387
TOTAL/TOTAL PRESSURE RATIO =	2.1356

HEAD COEFFICIENT RATIO =	2.3029
BLADE/JET SPEED RATIO =	.7650
THEORETICAL DEGREE OF REACTION =	.4378
MACH NUMBER AT STATION 0 =	.2045



SET PAGE RPM TOTAL/STATIC INLET TOTAL  
 NUMBER NUMBER 20000.0 PRESSURE RATIO PRESSURE TEMPERATURE  
 1 1 2.600 38.220 826.18

STATOR EXIT SOLUTION

STREAM LINE	RADIAL POSITION (IN)	X=R/RM	RADIAL SHFT (IN)	BLADE OPENING (IN)	BLADE EFFICIENCY	Y=VA /VAM	LOSS COEFFICIENT	ZETA*	FLOW RATE FRACTION
1	2.784	.865	0.0000	.2126	.9134	1.1017	.0866	.0866	0.0000
2	3.003	.940	0.0000	.2347	.9105	1.0469	.0895	.0895	.2518
3	3.175	1.000	0.0290	.2526	.9082	1.0000	.0918	.0918	.4710
4	3.432	1.074	0.0000	.2745	.9062	1.9401	.0938	.0938	.7554
5	3.627	1.135	0.0000	.2926	.9046	.8905	.0954	.0954	1.0000

ABSOLUTE VELOCITY (FPS)

STREAM LINE	AXIAL COMPONENT	RADIAL COMPONENT	TANGENTIAL COMPONENT	OVERALL VELOCITY	AXIAL COMPONENT	RADIAL COMPONENT	TANGENTIAL COMPONENT	OVERALL VELOCITY	WHEEL VELOCITY
1	436.14	-17.50	963.46	1057.73	436.14	-17.50	401.05	649.57	482.41
2	414.48	3.94	905.45	995.81	414.48	3.94	301.31	563.21	524.14
3	395.90	9.06	857.16	944.21	395.90	9.06	299.44	496.47	557.72
4	372.19	32.33	799.38	882.37	372.19	32.33	200.44	423.97	598.94
5	352.54	41.83	752.17	831.74	352.54	41.83	119.14	374.47	633.03

RELATIVE VELOCITY (FPS)

STREAM LINE	ABSOLUTE	RELATIVE	MACH NUMBER	FLOW ANGLE (DEG)	TEMPERATURE (DEG. R)	PRESSURE (PSI)	TEMPERATURE (DEG. R)	PRESSURE RATIO
1	.93	.57						
2	.87	.49						
3	.82	.43						
4	.76	.37						
5	.71	.32						
					TOTAL	STATIC	TOTAL	STATIC
					626.18	533.08	36.051	20.529
					626.18	543.66	36.261	22.113
					626.18	551.99	36.433	23.413
					626.18	561.39	36.646	25.005
					626.18	568.81	36.811	26.286
							TOTAL	STATIC
							101/101	101/51A
							1.0602	1.6622
							1.0500	1.7264
							1.0391	1.7911
							1.0279	1.8535
							1.0163	1.9153



SET NUMBER PAGE NUMBER RPM INITIAL/STATIC PRESSURE RATIO INLET TOTAL PRESSURE (PSI) INLET TOTAL TEMPERATURE (DEG. R) TOTAL STATIC PRESSURE (PSI) TOTAL TEMPERATURE (DEG. R) FLOW RATE

1 2 20000.0 2.600 38.220 626.18

ROTOR EXIT SOLUTION

STREAM LINE	RADIAL POSITION	X=R/RM	RADIAL SHIFT	BLADE OPENING	BLADE	Y=VA /VAM	EFFICIENCY	LOSS COEFFICIENT	CONTINUITY	FLOW RATE
1	2.693	.825	-.0710	.1912	.9841	.8925	.1076	.1076	.1076	0.0000
2	3.020	.925	-.0168	.2218	.9514	.8962	.1039	.1039	.1039	.2284
3	3.265	1.000	-.0405	.2447	1.0000	.8990	.1011	.1011	.1011	.4264
4	3.585	1.098	-.1537	.2747	1.0944	.9058	.0943	.0943	.0943	.7241
5	3.837	1.175	-.2100	.2983	1.1922	.9111	.0889	.0889	.0889	1.0000

ABSOLUTE VELOCITY (FPS)

STREAM LINE	AXIAL COMPONENT	RADIAL COMPONENT	TANGENTIAL COMPONENT	OVERALL VELOCITY	AXIAL COMPONENT	RADIAL COMPONENT	TANGENTIAL COMPONENT	OVERALL VELOCITY	WHEEL VELOCITY
1	399.16	-16.01	-490.56	632.64	399.16	-16.01	-490.56	632.64	470.02
2	386.22	3.67	-461.29	626.23	386.22	3.67	-461.29	626.23	527.07
3	405.61	9.28	-310.61	521.49	405.61	9.28	-310.61	521.49	569.88
4	443.92	38.56	-302.49	538.56	443.92	38.56	-302.49	538.56	625.77
5	483.56	57.37	-296.36	570.04	483.56	57.37	-296.36	570.04	669.68

MACH NUMBER FLOW ANGLE (DEG)

STREAM LINE	ABSOLUTE	RELATIVE	ABSOLUTE	RELATIVE	TEMPERATURE (DEG. R)	TEMPERATURE (DEG. R)	PRESSURE (PSI)	PRESSURE RATIO
1	.59	.87	-50.87	-67.44	510.46	477.15	12.846	2.3494
2	.49	.87	-43.05	-66.48	515.51	492.20	14.631	2.6217
3	.48	.91	-39.20	-65.76	515.25	492.44	14.718	2.6163
4	.50	.95	-34.27	-64.45	515.00	490.86	14.630	2.6085
5	.53	1.00	-31.51	-63.41	513.91	486.87	14.240	2.6214

EQUIVALENT INLET PRESSURE (PSI) EQUIVALENT INLET TEMPERATURE (DEG. R) EQUIV/STATIC PRESSURE RATIO

25.502  
567.21  
570.32  
573.64  
579.08  
584.26

2.0  
1.8  
1.8  
1.9  
2.0



SET PAGE RPM TOTAL/STATIC INLET TOTAL INLET TOTAL  
 NUMBER NUMBER PRESSURE RATIO PRESSURE TEMPERATURE  
 (DEG. R)

1 3 20000.0 2.600 38.220 626.18

OVERALL TURBINE CHARACTERISTICS

STREAM LINE	PRESSURE RATIO TOT/STA	TOT/STA	EFFICIENCY TOT/TOT	HEAD COEFFICIENT	BLADE/JET SPEED RATIO	THEORETICAL DEGREE OF REACTION
1	2.9751	.6905	.8535	8.6546	.3399	.3919
2	2.6122	.7367	.8667	6.5718	.3901	.3968
3	2.5968	.7424	.8711	5.7731	.4162	.4513
4	2.6125	.7400	.8765	5.0333	.4457	.5242
5	2.6840	.7295	.8793	4.6155	.4655	.5865

MASS AVERAGED QUANTITIES

HORSE POWER = 185.30 (HP)  
 MOMENT = 48.66 (FT-LB)  
 FLOW RATE = 4.89 (LB/SEC)

REFERRED RPM = 18197.55 (RPM)  
 REFERRED HORSE POWER = 64.84 (HP)  
 REFERRED MOMENT = 18.73 (FT-LB)  
 REFERRED FLOW RATE = 2.07 (LB/SEC)

TOTAL/STATIC EFFICIENCY = .7323  
 TOTAL/STATIC EFFICIENCY = .7202  
 TOTAL/STATIC PRESSURE RATIO = 2.6620  
 TOTAL/STATIC PRESSURE RATIO = 2.6350

HEAD COEFFICIENT = 6.4033  
 BLADE/JET SPEED RATIO = .4081  
 THEORETICAL DEGREE OF REACTION = .4659  
 MACH NUMBER AT STATION 0 = .2061





SET PAGE TOTAL/STATIC INLET TOTAL INLET TOTAL  
 NUMBER NUMBER 30000.0 RPM PRESSURE RATIO PRESSURE TEMPERATURE  
 1 1 2.000 38.220 658.18

STATOR EXIT SOLUTION

STREAM LINE	RADIAL POSITION (IN)	X=R/RM	RADIAL SHIFT (IN)	BLADE OPENING	Y=VA /VAM	EFFICIENCY	LOSS COEFFICIENT	ZFIAX CONTINUITY	FLOW RATE FRACTION
1	2.764	.865	0.0000	.2126	1.1042	.9205	.0795	.0795	0.0000
2	3.001	.900	0.0000	.2327	1.0400	.9159	.0841	.0841	.2332
3	3.192	1.000	0.0290	.2526	1.0000	.9123	.0877	.0877	.4727
4	3.432	1.074	0.0000	.2745	.9393	.9098	.0902	.0902	.7266
5	3.627	1.135	0.0000	.2926	.8892	.9077	.0923	.0923	1.0000

ABSOLUTE VELOCITY (FPS)

STREAM LINE	AXIAL COMPONENT	RADIAL COMPONENT	TANGENTIAL COMPONENT	OVERALL VELOCITY	AXIAL COMPONENT	RADIAL COMPONENT	TANGENTIAL COMPONENT	OVERALL VELOCITY	WUVEL VELOCITY
1	427.64	-17.15	944.68	1037.11	427.64	-17.15	221.06	481.71	723.62
2	405.86	3.86	896.61	975.10	405.86	3.86	100.40	418.12	786.21
3	387.29	8.86	838.53	923.69	387.29	8.86	1.94	387.40	836.58
4	363.80	31.60	781.35	862.47	363.80	31.60	-117.06	383.47	898.41
5	344.40	40.86	734.79	812.52	344.40	40.86	-214.76	407.92	949.55

RELATIVE VELOCITY (FPS)

MACH NUMBER      FLOW ANGLE (DEG. R)      TEMPERATURE (DEG. R)      PRESSURE (PSI)      TOTAL      STATIC      TOT/TOT      TOT/STA

STREAM LINE	ABSOLUTE	RELATIVE	ABSOLUTE	RELATIVE	TOTAL	STATIC	TOTAL	STATIC	TOT/TOT	TOT/STA
1	.91	.42	65.65	27.34	626.18	536.68	36.326	21.173	1.0521	1.8052
2	.85	.36	65.41	13.90	626.18	547.06	36.474	22.733	1.0422	1.6813
3	.80	.34	65.21	.29	626.18	555.18	36.601	24.030	1.0390	1.5917
4	.74	.33	65.04	-17.84	626.18	564.28	36.784	25.554	1.0350	1.4957
5	.69	.35	64.89	-31.95	626.18	571.24	36.927	26.778	1.0350	1.4273



SET NUMBER PAGE NUMBER RPM TOTAL/STATIC PRESSURE (PSI) INLET TOTAL TEMPERATURE (DEG. R) TOTAL TEMPERATURE (DEG. R)

1	2	30000.0	2.600	30.220	626.18
---	---	---------	-------	--------	--------

KOTOR EXIT SOLUTION

STREAM LINE	RADIAL POSITION	X=R/RM	RADIAL SHIFT	BLADE OPENING	BLADE EFFICIENCY	Y=VA /VAM	LOSS COEFFICIENT	ZETA* CONTINUITY	FLOW RATE FRACTION
1	2.693	.825	.0710	.1912	.9210	.9966	.0790	.0790	0.0000
2	3.020	.925	-.0168	.2218	.9055	.9100	.0946	.0946	.2200
3	3.265	1.000	-.0405	.2447	.8938	1.0000	.1063	.1063	.4135
4	3.585	1.098	-.1537	.2747	.9052	1.1540	.0949	.0949	.7111
5	3.837	1.175	-.2100	.2983	.9141	1.3010	.0859	.0859	1.0000

ABSOLUTE VELOCITY (FPS)

STREAM LINE	AXIAL COMPONENT	RADIAL COMPONENT	TANGENTIAL COMPONENT	OVERALL VELOCITY	AXIAL COMPONENT	RADIAL COMPONENT	TANGENTIAL COMPONENT	OVERALL VELOCITY	WHEEL VELOCITY
1	391.31	-15.70	-236.68	457.59	391.31	-15.70	-241.70	469.89	705.03
2	357.27	3.39	-30.13	358.57	357.27	3.39	-320.74	485.14	790.61
3	393.64	8.98	-17.07	393.11	393.64	8.98	-371.65	495.23	854.75
4	451.10	39.35	-8.80	454.89	451.10	39.35	-447.45	500.96	939.25
5	510.82	60.61	-15.94	514.65	510.82	60.61	-1020.51	1142.82	1004.53

RELATIVE VELOCITY (FPS)

STREAM LINE	ABSOLUTE	RELATIVE	FLOW ANGLE (DEG)	TEMPERATURE (DEG. R)	PRESSURE (PSI)	STATIC	TOTAL	101/10T	101/51A
1	43	.96	-31.12	484.65	462.22	14.009	12.324	2.7282	3.1017
2	33	.82	-4.62	506.51	495.50	16.488	16.300	2.5181	2.4700
3	36	.88	-2.49	507.01	494.15	16.387	14.978	2.3324	2.5517
4	42	.97	-1.11	507.90	490.70	16.502	14.626	2.3160	2.6151
5	48	1.06	-1.79	507.39	485.35	16.416	14.053	2.3282	2.7198

EQUIV/STATIC PRESSURE RATIO

STREAM LINE	EQUIVALENT TEMPERATURE (DEG. R)	EQUIVALENT INLET PRESSURE (PSI)	EQUIV/STATIC PRESSURE RATIO
1	553.70	23.629	1.9
2	562.19	25.020	1.6
3	570.23	25.477	1.8
4	582.07	28.567	2.0
5	594.03	30.706	2.2



SET NUMBER	PAGE NUMBER	RPM	TOTAL/STATIC PRESSURE RATIO	INLET TOTAL PRESSURE (PSI)	INLET TOTAL TEMPERATURE (DEG. R)
1	3	30000.0	2.600	30.220	626.10

OVERALL TURBINE CHARACTERISTICS

STREAM LINE	PRESSURE RATIO TOT/STA	EFFICIENCY TOT/STA	HEAD COEFFICIENT	BLADE/JET SPEED RATIO	THEORETICAL DEGREE OF REACTION
1	3.1012	.9067	3.9706	.5018	.4379
2	2.4950	.8973	2.8019	.5974	.4006
3	2.5517	.8956	2.5240	.6293	.4707
4	2.6131	.8848	2.2375	.6685	.5473
5	2.7198	.8844	2.0751	.6942	.6112

MASS AVERAGED QUANTITIES

HORSE POWER = 203.29 (HP)  
 MOMENTUM FLOW RATE = 35.24 (FT-LB)  
 FLOW RATE = 4.88 (LB/SEC)

REFERRED RPM = 27296.32  
 REFERRED HORSE POWER = 70.44 (HP)  
 REFERRED MOMENTUM FLOW RATE = 13.55 (FT-LB)  
 REFERRED FLOW RATE = 2.06 (LB/SEC)

TOTAL/STATIC EFFICIENCY = .8050  
 TOTAL/STATIC PRESSURE RATIO = .8209  
 TOTAL/STATIC PRESSURE RATIO = 2.6433  
 TOTAL/STATIC PRESSURE RATIO = 2.5736

HEAD COEFFICIENT = 2.6467  
 BLADE/JET SPEED RATIO = .6147  
 THEORETICAL DEGREE OF REACTION = .4858  
 MACH NUMBER AT STATION 0 = .2058



SET PAGE RPM TOTAL/STATIC INLET TOTAL INLET TOTAL  
 NUMBER NUMBER 15000.0 PRESSURE RATIO PRESSURE TEMPERATURE  
 1 1 2.800 41.160 636.67

STATOR EXIT SOLUTION

STREAM LINE	RADIAL POSITION (IN)	X=R/RM	RADIAL SHIFT (IN)	BLADE OPENING (IN)	Y=VA./VAH	BLADE EFFICIENCY	LOSS COEFFICIENT	7FIA* CONTINUITY	7FIA* CONTINUITY	FLOW RATE FRACTION
1	2.784	.865	0.0000	.2126	1.1050	.9160	.0840	.0840	.0840	0.0000
2	3.003	1.040	0.0000	.2347	1.0481	.9091	.0909	.0909	.0909	.2504
3	3.195	1.000	0.0290	.2526	1.0000	.9036	.0964	.0964	.0964	.4688
4	3.432	1.074	0.0000	.2745	1.0401	.9019	.0981	.0981	.0981	.7536
5	3.627	1.135	0.0000	.2926	.8910	.9005	.0995	.0995	.0995	1.0000

ABSOLUTE VELOCITY (FPS)

STREAM LINE	AXIAL COMPONENT	RADIAL COMPONENT	TANGENTIAL COMPONENT	OVERALL VELOCITY	AXIAL COMPONENT	RADIAL COMPONENT	TANGENTIAL COMPONENT	OVERALL VELOCITY	WHFFI VELOCITY
1	464.88	-18.65	1026.95	1127.43	464.88	-18.65	665.14	811.71	361.81
2	440.92	4.19	963.20	1059.33	440.92	4.19	570.09	720.72	393.10
3	420.70	9.63	910.85	1003.36	420.70	9.63	492.56	647.84	418.29
4	395.51	34.35	849.46	937.65	395.51	34.35	400.26	563.75	449.20
5	374.84	44.47	799.73	884.34	374.84	44.47	324.96	498.07	474.77

RELATIVE VELOCITY (FPS)

STREAM LINE	MACH NUMBER			TEMPERATURE (DEG. R)			PRESSURE (PSI)			PRESSURE RATIO		
	ABSOLUTE	RELATIVE	FLOW ANGLE (DEG)	ABSOLUTE	RELATIVE	STATIC	TOTAL	STATIC	TOTAL	101/101	101/STA	TOT/STA
1	1.00	.72		65.65	55.05	530.90	39.586	20.430	1.0667	1.0667	2.0146	
2	.93	.63		65.41	52.28	541.20	38.737	22.435	1.0656	1.0656	1.8313	
3	.87	.54		65.21	49.50	552.60	38.074	23.528	1.0647	1.0647	1.7347	
4	.81	.48		65.04	45.74	563.26	37.161	25.546	1.0630	1.0630	1.612	
5	.75	.42		64.89	40.93	571.59	36.376	26.999	1.0453	1.0453	1.5245	





SET NUMBER PAGE RPM TOTAL/STATIC PRESSURE (PSI) INLET TOTAL PRESSURE (PSI) INLET TOTAL TEMPERATURE (DEG. R) 636.67

1 2 15000.0 2.800 41.160

ROTOR EXIT SOLUTION

STREAM LINE	RADIAL POSITION	X=R/RM	SHIFT	RADIAL OPENING	BLADE	Y=VA /VAM	EFFICIENCY	BLADE	LOSS	CONTINUITY	ZETA*	FLOW RATE FRACTION
1	2.693	.825	.0710	.1912	.9788	.8773	.1237	.1237	.1237	.1237	.1237	0.0000
2	3.020	.925	-.0168	.2318	.9741	.8768	.1233	.1233	.1233	.1233	.1233	.2333
3	3.265	1.000	-.0405	.2447	1.0000	.8764	.1237	.1237	.1237	.1237	.1237	.2333
4	3.505	1.098	-.1537	.2742	1.0619	.8807	.1194	.1194	.1194	.1194	.1194	.7281
5	3.837	1.175	-.2100	.2983	1.1319	.8841	.1160	.1160	.1160	.1160	.1160	1.0000

ABSOLUTE VELOCITY (FPS)

STREAM LINE	AXIAL COMPONENT	TANGENTIAL COMPONENT	OVERALL VELOCITY	AXIAL COMPONENT	RADIAL COMPONENT	TANGENTIAL COMPONENT	OVERALL VELOCITY	WHEEL VELOCITY
1	430.45	-683.39	807.84	430.45	-17.27	-1035.90	1121.91	352.51
2	428.37	-590.70	730.28	429.77	4.08	-986.09	1075.48	395.31
3	459.79	-520.75	793.66	439.79	18.06	-976.54	1071.05	427.39
4	427.02	-587.24	690.69	467.02	40.56	-976.57	1083.25	469.33
5	497.79	-492.21	702.53	497.79	59.06	-994.47	1113.66	502.26

MACH NUMBER

STREAM LINE	ABSOLUTE	RELATIVE	FLOW ANGLE (DEG)	TEMPERATURE (DEG. R)	PRESSURE (PSI)	PRESSURE RATIO
1	.75	1.04	-57.80	534.74	480.44	12.923
2	.67	.99	-54.00	534.79	490.41	14.088
3	.65	.98	-51.31	534.20	493.01	14.417
4	.63	.99	-47.37	533.55	493.85	14.637
5	.65	1.03	-44.68	532.34	491.27	14.410

EQUIVALENT INLET PRESSURE (PSI)

STREAM LINE	EQUIVALENT INLET PRESSURE (PSI)	EQUIV/STATIC PRESSURE RATIO
1	28.723	2.2
2	29.092	2.1
3	29.513	2.1
4	30.268	2.1
5	30.974	2.1



SET NUMBER	PAGE NUMBER	RPM	TOTAL/STATIC PRESSURE RATIO	INLET TOTAL PRESSURE (PSI)	INLET TOTAL TEMPERATURE (DEG. R)
1	3	15000.0	2.800	41.160	636.67

OVERALL TURBINE CHARACTERISTICS

STREAM LINE	PRESSURE RATIO TOT/STA	EFFICIENCY TOT/10T	HEAD COEFFICIENT	BLADE/JET SPEED RATIO	THEORETICAL DEGREE OF REACTION
1	3.1842	.7991	16.4609	.2464	.3563
2	2.7216	.8113	13.0634	.2767	.3885
3	2.8550	.8167	11.3249	.2972	.4377
4	2.8120	.8267	9.6977	.3211	.5018
5	2.8563	.8313	8.7936	.3372	.5619

MASS AVERAGED QUANTITIES

HORSE POWER	=	182.97	(HP)
MOMENT	=	64.06	(FT-LB)
FLOW RATE	=	5.25	(LB/SEC)
REFERRED RPM	=	13335.26	(RPM)
REFERRED HORSE POWER	=	50.96	(HP)
REFERRED MOMENT	=	22.88	(FT-LB)
REFERRED FLOW RATE	=	2.08	(LB/SEC)

TOTAL/STATIC EFFICIENCY	=	.6154
TOTAL/STATIC PRESSURE RATIO	=	.8174
TOTAL/STATIC PRESSURE RATIO	=	2.1579

HEAD COEFFICIENT	=	11.6793
BLADE/JET SPEED RATIO	=	.2926
THEORETICAL DEGREE OF REACTION	=	.4468
MACH NUMBER AT STATION 0	=	.2072



SET NUMBER 1 PAGE 1 RPM 20000.0  
 IDIAL/STATIC PRESSURE RATIO 2.800  
 INFL TOTAL TEMPERATURE 41.160  
 PRESSURE LOSS COEFFICIENT 6.36.67  
 ZETA\* CONTINUITY 1.0000

STATOR EXIT SOLUTION

STREAM LINE	RADIAL POSITION (IN)	X=R/RM	RADIAL SHIFT (IN)	BLADE OPENING (IN)	Y=VA /VAM	EFFICIENCY	BLADE LOSS COEFFICIENT	ZETA*	CONTINUITY	FLOW RATE FRACTION
1	2.744	.865	0.0000	.2126	1.1018	.8146	.0054	.0854	0.0000	
2	3.073	.900	0.0000	.2327	1.0470	.8137	.0083	.0883	.2509	
3	3.195	1.000	0.0000	.2528	1.0000	.8074	.0306	.0906	.4698	
4	3.432	1.074	0.0000	.2745	.9400	.8071	.0529	.0929	.7546	
5	3.627	1.135	0.0000	.2926	.8902	.8052	.0948	.0948	1.0000	

ABSOLUTE VELOCITY (FPS)					RELATIVE VELOCITY (FPS)				
STREAM LINE	AXIAL COMPONENT	RADIAL COMPONENT	TANGENTIAL COMPONENT	OVERALL VELOCITY	AXIAL COMPONENT	RADIAL COMPONENT	TANGENTIAL COMPONENT	OVERALL VELOCITY	WHEEL VELOCITY
1	450.26	-18.06	994.65	1091.97	450.26	-18.06	512.24	682.24	482.41
2	427.89	4.06	934.73	1028.02	427.89	4.06	410.59	593.04	524.14
3	408.68	9.35	884.83	974.69	408.68	9.35	327.11	523.55	557.72
4	384.14	33.36	825.04	910.20	384.14	33.36	226.10	446.99	598.94
5	363.79	43.16	776.17	858.29	363.79	43.16	143.14	393.32	633.03

MACH NUMBER				TEMPERATURE (DEG. R)				PRESSURE (PSI)	
STREAM LINE	ABSOLUTE	RELATIVE	FLOW ANGLE (DEG)	ABSOLUTE	RELATIVE	TOTAL	STATIC	TOTAL	STATIC
1	.96	.60	65.65	636.67	48.69	537.45	21.405	38.729	1.0628
2	.90	.52	65.41	636.67	43.82	548.73	23.161	30.967	1.0563
3	.84	.45	65.21	636.67	38.68	557.62	24.622	30.161	1.0510
4	.78	.38	65.04	636.67	30.48	567.66	26.365	30.394	1.0448
5	.73	.33	64.89	636.67	21.48	575.37	27.768	30.575	1.0400



SET NUMBER    KAGE NUMBER    RPM    IORIAL/STATIC PRESSURE RATIO    INLET TOTAL PRESSURE (PSI)    INLET TOTAL TEMPERATURE (DEG. R)    636.67

1    2    20000.0    2.600    41.160

KOTOR EXIT SOLUTION

STREAM LINE	RADIAL POSITION	X=R/RM	SHIFT	RADIAL OPENING	BLADE	Y=VA /VAM	EFFICIENCY	LOSS COEFFICIENT	CONTINUITY	ZETA*	FLOW RATE FRACTION
1	2.623	.825	.0710	.1912	.8933	.9833	.1067	.1067	.1067	.1067	0.0000
2	3.020	.925	-.0168	.2218	.8963	.9561	.1037	.1037	.1037	.1037	.2288
3	3.265	1.000	-.0405	.2447	.8985	1.0000	.1015	.1015	.1015	.1015	.4274
4	3.585	1.098	-.1537	.2747	.9038	1.0908	.0962	.0962	.0962	.0962	.7235
5	3.837	1.175	-.2100	.2983	.9000	1.1853	.0920	.0920	.0920	.0920	1.0000

RELATIVE VELOCITY (FPS)

STREAM LINE	AXIAL COMPONENT	RADIAL COMPONENT	TANGENTIAL COMPONENT	OVERALL VELOCITY	AXIAL COMPONENT	RADIAL COMPONENT	TANGENTIAL COMPONENT	OVERALL VELOCITY	WHEEL VELOCITY
1	413.86	-16.60	-525.94	669.45	413.86	-16.60	-925.95	1078.65	470.02
2	402.41	3.82	-327.32	565.52	403.41	3.82	-924.39	1008.19	527.07
3	420.89	9.63	-344.72	557.01	420.89	9.63	-934.57	1025.02	568.85
4	459.09	39.87	-334.21	569.26	459.09	39.87	-959.58	1064.86	625.77
5	478.88	59.19	-326.97	599.41	498.88	59.19	-996.65	1116.11	669.68

TEMPERATURE (DEG. R)

STREAM LINE	ABSOLUTE	RELATIVE	ABSOLUTE	RELATIVE	TOTAL	STATIC	TOTAL	STATIC	TOT/TOT	TOT/STA
1	.62	1.01	-51.80	-67.44	515.68	470.38	12.00	13.072	2.4211	3.1486
2	.52	.93	-44.64	-64.40	520.28	493.67	17.822	14.914	2.2266	2.7599
3	.51	.94	-40.91	-65.76	519.95	494.14	17.961	15.079	2.2216	2.7388
4	.52	.98	-39.06	-64.45	519.63	492.66	18.003	14.940	2.2253	2.7551
5	.55	1.03	-33.24	-63.41	518.46	488.56	17.872	14.517	2.3031	2.8352

EQUIVALENT INLET PRESSURE (PSI)

1	27.146
2	27.823
3	28.526
4	29.549
5	30.719

EQUIV/STATIC PRESSURE RATIO

1	2.1
2	1.9
3	1.9
4	2.0
5	2.1





SET NUMBER	PAGE NUMBER	RPM	ISSUE/STATION PRESSURE (PSI)	TOTAL INLET TEMPERATURE (DEG. R)
1	3	20000.0	2.800	41.160
				636.67

OVERALL TURBINE CHARACTERISTICS

STREAM LINE	PRESSURE RATIO TOT/STA	EFFICIENCY TOT/101	HEAD COEFFICIENT	BLADE/JET SPEED RATIO	THEORETICAL DEGREE OF REACTION
1	3.1486	.6802	9.1863	.3299	.3902
2	2.7599	.8241	7.0225	.3776	.3282
3	2.7100	.8290	5.3225	.4032	.4541
4	2.7552	.8737	5.3619	.4319	.5247
5	2.6352	.8755	4.9165	.4510	.5869

MASS AVERAGED QUANTITIES

HORSE POWER = 200.91 (HP)  
 MOMENT FLOW RATE = 54.86 (FT-LB)  
 FLOW RATE = 5.24 (LB/SEC)

REFERRED RPM = 18047.01 (HP)  
 REFERRED HORSE POWER = 67.32 (HP)  
 REFERRED MOMENT FLOW RATE = 19.59 (FT-LB)  
 REFERRED FLOW RATE = 2.07 (LB/SEC)

TOTAL/STATIC EFFICIENCY = .7227  
 TOTAL/TOTAL EFFICIENCY = .8677  
 TOTAL/STATIC PRESSURE RATIO = 2.9114

HEAD COEFFICIENT RATIO = 6.3244  
 BLADE/JET SPEED RATIO = 3.3955  
 THEORETICAL DEGREE OF REACTION = .4664  
 MACH NUMBER AT STATION 0 = .2069



SET NUMBER 1  
 PAGE NUMBER 1  
 RPM 25000.0  
 TOTAL/STATIC PRESSURE RATIO 2.800  
 INLET TOTAL PRESSURE 41.160  
 INLET TOTAL TEMPERATURE 636.67

STATOR EXIT SOLUTION

STREAM LINE	RADIAL POSITION (IN)	X=R/RM	RADIAL SHIFT (IN)	BLADE OPENING (IN)	BLADE EFFICIENCY	Y=VA /VAM	LOSS COEFFICIENT	ZETA* CONTINUITY	FLOW RATE FRACTION
1	2.764	.865	0.0000	.2126	.9178	1.1033	.0822	.0822	0.0000
2	3.093	.740	0.0000	.2147	.9139	1.0426	.0861	.0861	.2527
3	3.132	1.000	0.0290	.2526	.9108	1.0000	.0892	.0892	.4721
4	3.432	1.074	0.0000	.2745	.9085	.9395	.0915	.0915	.7562
5	3.627	1.135	0.0000	.2926	.9065	.8897	.0935	.0935	1.0000

STREAM LINE	ABSOLUTE VELOCITY (FPS)					RELATIVE VELOCITY (FPS)				
	AXIAL COMPONENT	RADIAL COMPONENT	TANGENTIAL COMPONENT	OVERALL VELOCITY	AXIAL COMPONENT	RADIAL COMPONENT	TANGENTIAL COMPONENT	OVERALL VELOCITY	WHEEL VELOCITY	
1	434.12	-17.41	958.99	1052.81	434.12	-17.41	355.97	561.67	603.01	
2	412.21	3.92	900.48	990.35	412.21	3.92	245.31	479.70	655.17	
3	393.49	9.00	851.94	938.46	393.49	9.00	154.79	422.93	697.15	
4	369.73	32.11	794.09	876.54	369.73	32.11	45.42	373.89	748.67	
5	350.09	41.54	746.93	825.95	350.09	41.54	-44.36	355.32	791.29	

STREAM LINE	MACH NUMBER		FLOW ANGLE (DEG)		TEMPERATURE (DEG. R)		PRESSURE (PSI)		PRESSURE RATIO	
	ABSOLUTE	RELATIVE	ABSOLUTE	RELATIVE	TOTAL	STATIC	TOTAL	STATIC	101/TOT	TOT/51A
1	.92	.49	65.65	39.35	636.67	544.44	39.017	22.561	1.0549	1.8234
2	.86	.42	65.41	30.76	636.67	555.06	39.199	24.251	1.0500	1.6971
3	.81	.36	65.21	21.47	636.67	563.38	39.353	25.651	1.0449	1.6045
4	.75	.32	65.04	7.00	636.67	573.74	39.562	27.316	1.0404	1.5069
5	.70	.30	64.89	-7.22	636.67	579.60	39.724	28.648	1.0361	1.4357



SET PAGE RPM TOTAL/STATIC INLET TOTAL INLET TOTAL  
 NUMBER NUMBER PRESSURE RATIO PRESSURE TEMPERATURE TEMPERATURE  
 (PSI) (DEG. R)

1 2 25000.0 2.800 41.160 636.67

ROTOR EXIT SOLUTION

STREAM LINE	RADIAL POSITION	X=R/RM	RADIAL SHFT	BLADE OPENING	BLADE EFFICIENCY	Y=VA /VAM	LOSS COEFFICIENT	CONTINUITY	VELOCITY*	FLOW RATE FRACTION
1	2.693	.825	.0710	.1912	.9114	.9888	.0886	.0886	.0886	0.0000
2	3.020	1.000	-.0168	.2218	.9126	.9357	.0875	.0875	.0875	.2258
3	3.285	1.098	-.0405	.2447	.9134	1.0000	.0866	.0866	.0866	.4237
4	3.585	1.175	-.1537	.2747	.9175	1.1196	.0926	.0926	.0926	.7210
5	3.837	1.175	-.2100	.2983	.9028	1.2386	.0972	.0972	.0972	1.0000

ABSOLUTE VELOCITY (FPS)

STREAM LINE	AXIAL COMPONENT	RADIAL COMPONENT	TANGENTIAL COMPONENT	OVERALL VELOCITY	AXIAL COMPONENT	RADIAL COMPONENT	TANGENTIAL COMPONENT	OVERALL VELOCITY	WHEEL VELOCITY
1	411.06	-16.49	-401.70	574.98	411.06	-16.49	-899.22	1071.35	587.52
2	388.97	3.70	-234.66	454.28	388.97	3.70	-874.50	1074.50	658.04
3	415.71	9.51	-210.75	466.18	415.71	9.51	-923.07	1012.40	712.11
4	465.42	40.42	-190.99	504.70	465.42	40.42	-973.20	1079.52	762.21
5	514.87	61.09	-191.50	552.72	514.87	61.09	-1028.61	1151.90	837.11

235

MACH NUMBER FLOW ANGLE (DEC)

STREAM LINE	ABSOLUTE	RELATIVE	ABSOLUTE	RELATIVE	TEMPERATURE (DEG. R)	PRESSURE (PSI)	TEMPERATURE (DEG. R)	PRESSURE RATIO
1	.54	1.00	-44.34	-67.44	501.15	473.64	15.752	12.928
2	.42	.89	-31.10	-66.48	512.76	495.58	17.423	15.452
3	.43	.93	-26.89	-65.76	512.84	494.76	17.425	15.372
4	.46	.99	-22.31	-64.45	512.87	491.67	17.382	14.912
5	.51	1.07	-20.40	-63.41	511.83	486.21	16.948	14.178

EQUIVALENT INLET PRESSURE (PSI) EQUIVALENT INLET PRESSURE RATIO

569.15 2.0  
 574.60 1.8  
 580.05 2.0  
 588.24 2.2  
 596.62 2.2

STREAM LINE 1 2 3 4 5

101/10T 101/51A  
 2.6110 3.1828  
 2.3719 2.6272  
 2.3622 2.6244  
 2.3811 2.7604  
 2.4289 2.9032



SET NUMBER	PAGE NUMBER	RPM	TOTAL/STATIC PRESSURE RATIO	INLET TOTAL PRESSURE (PSI)	INLET TOTAL TEMPERATURE (DEG. R)
1	3	25000.0	2.800	41.160	636.67

OVERALL TURBINE CHARACTERISTICS

STREAM LINE	PRESSURE RATIO TOT/STA	EFFICIENCY TOT/STA	HEAD TOT/TOT	COEFFICIENT	BLADE/INLET SPEED RATIO	THEORETICAL DEGREE OF REACTION
1	3.1838	.7556	.8870	5.9273	.4107	.4397
2	2.6532	.7973	4.3511	4.794	.4254	.4254
3	2.9784	.7920	.8932	3.8622	.5080	.4848
4	2.2691	.7723	.8858	3.4370	.5394	.5610
5	2.9032	.7482	.8770	3.2078	.5583	.6253

MASS AVERAGED QUANTITIES

HORSE POWER =	221.79	(HP)
MOMENT =	46.59	(FT-LB)
FLOW RATE =	5.21	(LB/SEC)

REFERRED RPM =	22558.76	(HP)
REFERRED HORSE POWER =	71.48	(FT-LB)
REFERRED MOMENT =	16.64	(FT-LB)
REFERRED FLOW RATE =	2.06	(LB/SEC)

TOTAL/STATIC EFFICIENCY =	.7786
TOTAL/TOTAL EFFICIENCY =	.8885
TOTAL/STATIC PRESSURE RATIO =	2.7063
TOTAL/TOTAL PRESSURE RATIO =	2.4070

HEAD COEFFICIENT =	4.0544
BLADE/JET SPEED RATIO =	.4966
THEORETICAL DEGREE OF REACTION =	.5009
MACH NUMBER AT STATION 0 =	.2058





SET PAGE TOTAL/STATIC INLET TOTAL INLET TOTAL  
 NUMBER NUMBER RPM PRESSURE RATIO PRESSURE TEMPERATURE TEMPERATURE  
 1 1 30000.0 2.800 41.160 836.67 836.67

STATOR EXIT SOLUTION

STREAM LINE	RADIAL POSITION (IN)	X=R/RM	RADIAL SHIF (IN)	BLADE OPENINGS (IN)	Y=VA /VAM	EFFICIENCY	BLADE COEFFICIENT	LOSS	CONTINITY	Z/FIX	FLOW RATE FRACTION
1	2.764	.865	0.0000	.2126	1.1042	.9209	.0791	.0791	.0791	.0791	0.0000
2	3.003	.940	0.0000	.2347	1.0480	.9164	.0836	.0836	.0836	.0836	.2529
3	3.192	1.000	0.0000	.2546	1.0000	.9127	.0873	.0873	.0873	.0873	.4724
4	3.432	1.074	0.0000	.2745	.9393	.9101	.0899	.0899	.0899	.0899	.7563
5	3.627	1.135	0.0000	.2926	.8891	.9079	.0921	.0921	.0921	.0921	1.0000

RELATIVE VELOCITY (FPS)

STREAM LINE	AXIAL COMPONENT	RADIAL COMPONENT	TANGENTIAL COMPONENT	OVERALL VELOCITY	AXIAL COMPONENT	RADIAL COMPONENT	TANGENTIAL COMPONENT	OVERALL VELOCITY	WHFEL VELOCITY
1	434.48	-17.43	959.28	1053.69	434.48	-17.43	236.17	494.82	723.62
2	412.35	3.92	900.77	990.68	412.35	3.92	114.57	427.98	786.21
3	393.47	9.00	851.50	938.42	393.47	9.00	15.31	393.82	836.58
4	369.58	32.10	793.76	876.17	369.58	32.10	-104.65	385.45	898.41
5	349.84	41.51	746.41	825.37	349.84	41.51	-203.14	406.67	949.55

MACH NUMBER FLOW ANGLE (DEG. R) TEMPERATURE (DEG. R) PRESSURE (PSI) PRESSURE RATIO

STREAM LINE	ABSOLUTE	RELATIVE	ABSOLUTE	RELATIVE	TOTAL	STATIC	TOTAL	STATIC	TOT/TOT	TOT/ST/A
1	.92	.43	65.65	28.53	636.67	544.28	39.097	22.585	1.0528	1.8224
2	.86	.37	65.41	15.53	636.67	555.00	39.257	24.280	1.0185	1.6952
3	.81	.34	65.21	2.23	636.67	563.39	39.496	25.680	1.0448	1.6038
4	.75	.33	65.04	-15.81	636.67	573.79	39.594	27.348	1.0195	1.5051
5	.70	.34	64.89	-30.14	636.67	579.98	39.749	28.600	1.0355	1.4352



SET NUMBER PAGE RPM IBIAL/STATIC PRESSURE TOTAL INLET TOTAL TEMPERATURE (DEG. R)

1 2 30000.0 2.800 41.160 636.67

ROTOR EXIT SOLUTION

STREAM LINE	RADIAL POSITION	X=R/RM	SHFT	RADIAL OPENING	BLADE	Y=VA /VAM	EFFICIENCY	LOSS	COEFFICIENT	CONTINUITY	RELATION RATE
1	2.693	.825	.0710	.1912	.9952	.9230	.0720	.0916	.0770	.0770	0.0000
2	3.020	.925	-.0168	.2216	.9151	.9084	.0916	.1025	.0916	.0916	.2210
3	3.245	1.000	-.0405	.2447	1.0000	.8975	.1025	.1025	.1025	.1025	.4132
4	3.545	1.098	-.1537	.2747	1.1427	.9052	.0949	.0949	.0949	.0949	.7126
5	3.837	1.175	-.2100	.2983	1.2872	.9112	.0888	.0888	.0888	.0888	1.0000

ABSOLUTE VELOCITY (FPS)

STREAM LINE	AXIAL COMPONENT	RADIAL COMPONENT	TANGENTIAL COMPONENT	OVERALL VELOCITY	AXIAL COMPONENT	RADIAL COMPONENT	TANGENTIAL COMPONENT	OVERALL VELOCITY	RELATIVE VELOCITY (FPS)	OVERALL VELOCITY	WHEEL VELOCITY
1	409.70	-16.43	-280.93	497.03	409.70	-16.43	-280.93	497.03	1067.81	1067.81	705.03
2	374.73	3.58	-24.78	384.09	376.73	3.58	-24.78	384.09	1045.39	1045.39	790.61
3	423.69	7.42	-32.36	476.95	411.60	9.42	-31.41	482.61	1094.97	1094.97	854.78
4	423.07	41.00	-48.47	476.52	472.07	41.00	-48.47	476.52	1058.69	1058.69	933.65
5	527.93	62.87	-54.16	536.39	529.93	62.87	-54.16	536.39	1185.58	1185.58	1004.53

238

MACH NUMBER FLOW ANGLE (DEG)

STREAM LINE	ABSOLUTE	RELATIVE	ABSOLUTE	RELATIVE	TEMPERATURE (DEG. R)	PRESSURE (PSI)	PRESSURE RATIO
1	.47	1.01	-34.44	-67.44	TOTAL	TOTAL	TOT/101
2	.35	.86	-11.23	-66.48	STATIC	STATIC	2.6323
3	.38	.92	-8.21	-65.76	467.57	12.501	2.4304
4	.44	1.01	-5.86	-64.45	496.69	15.613	2.6363
5	.50	1.10	-5.84	-63.41	495.22	16.885	2.4377
					491.54	14.849	2.6250
					485.72	14.106	2.4293
							2.4517

EQUIVALENT INLET PRESSURE (PSI)

STREAM LINE	EQUIVALENT INLET PRESSURE (PSI)	EQUIV/STATIC PRESSURE RATIO
1	25.336	2.0
2	26.790	1.7
3	28.233	1.8
4	30.569	2.1
5	32.805	2.3



SET NUMBER	PAGE NUMBER	RPM	TOTAL/STATIC PRESSURE RATIO	INLET TOTAL PRESSURE (PSI)	INLET TOTAL TEMPERATURE (DEG. R)
1	3	30000.0	2.800	41.160	636.67

OVERALL TURBINE CHARACTERISTICS

STREAM LINE	PRESSURE RATIO TOT/STA	TOT/STA	EFFICIENCY TOT/TOT	HEAD COEFFICIENT	BLADE/JET SPEED RATIO	THEORETICAL DEGREE OF REACTION
1	3.2826	.885	.968	4.7465	.4870	.4539
2	2.4363	.887	.897	5.944	.5779	.4213
3	2.4950	.887	.887	5.6266	.6090	.4808
4	2.4273	.787	.885	2.3554	.6461	.5637
5	2.4517	.7603	.8826	2.2265	.6702	.6262

MASS AVERAGED QUANTITIES

HORSE POWER =	229.78	(HP)
MOMENT =	40.14	(FT-LB)
FLOW RATE =	5.22	(LB/SEC)
REFERRED RPM =	27070.52	(RPM)
REFERRED HORSE POWER =	73.89	(HP)
REFERRED MOMENT =	14.34	(FT-LB)
REFERRED FLOW RATE =	2.07	(LB/SEC)

TOTAL/STATIC EFFICIENCY =	.8018
TOTAL/STATIC EFFICIENCY =	.8917
TOTAL/STATIC PRESSURE RATIO =	2.8001
TOTAL/STATIC PRESSURE RATIO =	2.4824

HEAD COEFFICIENT =	2.8270
BLADE/JET SPEED RATIO =	.5948
THEORETICAL DEGREE OF REACTION =	.5073
MACH NUMBER AT STATION 0 =	.2062



APPENDIX: G

COMPUTER LISTING





MAIN T=0004 IS ON CR0025 USING 00147 BLKS R=0000

```

0001 FTN4,L
0002 BLOCK DATA
0003 COMMON/ABA/BA17,BLEX
0004 COMMON/CUR/COSL(10)
0005 COMMON/TOL/TOL1,TOL2,TOL3,TOL4
0006 COMMON/TR5/TRAS
0007 COMMON/GAS/CP,GAM,EMME,ERRE,EXP1,EXP2,VIS2,VIS3
0008 COMMON/CDZ/ICOR,ICDZ,IINC,IAI,ICL,IAN,ICON
0009 COMMON/MAC/IN
0010 COMMON/IWT/IND,INZ,IWR
0011 COMMON/AUS/XCL
0012 COMMON/CSS/CJ,G,Q1
0013 COMMON/VAR1/RC(10),RSOLD2,RSOLD3,RSOLD4,ASFO,RSFO,RFO,ARFO,
0014 *RR(10),RROLD2,RROLD3,RROLD4,CV,CK,VA1(10),DALF(10),DBET(10),
0015 *ASF,AMS,B1(20)
0016 COMMON/VAR2/B6(20),ZR,ZS,ARF,R2(20),PR,AMR,VU1(10)
0017 COMMON/VAR3/PTE(10),RS1,RS3,RSS,T2(10)
0018 COMMON/VAR4/BR1,RR2,RR3,RR1,RR3,RR5,VA2(10)
0019 COMMON/VAR5/PRAT1(10),RINCI(10),ALFA1(10),BETA1(10),ZETA1(10),
0020 *V2(10),ALFA2(10),BETA2(10)
0021 COMMON/VAR6/PT2(10),TT2(10),PT1(10),DELH(10),ALFA2(10),VU2(10),
0022 *WR2(10),TPS(10),T2TS(10)
0023 COMMON/VAR7/TTIS(5),BETAT(5),ETAT(5),ETAI(10),ETAS(10),ETAR(10),
0024 *RSTAR(10),AKIS(10),PSTR(10)
0025 COMMON/VAR8/DR1(10),AMW1(10),AMV2(10),BETET(10),PRAT1(10),AMR2(
0026 *10),YS(10),X1(10),AREA1(10),ZETAPS(10),WPER1(10),YR(10),X2(10)
0027 COMMON/VAR9/ZETAR(10),ZETAPR(10),AS(10),AR(10),SI1(10),SI2(10),
0028 *S1(10),DSDX1(10),W1(10),HE(10)
0029 COMMON/VAR10/WU1(10),DHEDX(10),DSDX2(10),RI1(10),RI2(10),
0030 *RI3(10),RI4(10),RI(10),SR1(10),SR2(10)
0031 COMMON/VAR11/YOLD(10),AA(10),SR(10),PRAT2(10),WPER2(10),
0032 *RDWX(10),TTIS(10),PRAT3(10),SS(10),ALFA(10)
0033 COMMON/VAR12/BETA(10),DELR(10),WPERO(10),ZETAS(10),ZETAR1(20),
0034 *ZETAR3(20),ZETARS(20),R1(20),A1(20),T1(20)
0035 COMMON/VAR13/ST1(20),IRR(20),R2(20),A2(20),RINC(20),DR(10),
0036 *BETO(10),STALII(10),AREA2(10),UR1(10)
0037 COMMON/VAR14/WLEM,PRATS,OMEG
0038 COMMON/AL1/ALFA1(10),V1(10),TT0,RPM,RS(10),SI,TNI,H,D,CI,T1(10),
0039 *P1(10),T0,TEI,ALI,RESP,XX,ANG20,AMS1(10),S,TN,C,TE,AL,SO,TNO,
0040 *CO,TEU,U(10),D11,D10,D21,D20,ANG21,ALFAX,T11,PT0,A10,AMC
0041 COMMON/AL2/BETA2(10),KETA1(10),BETA0(10),W2(10),TTE(10),U2(10),
0042 *SIR,TNR,HR,DZ,CIR,TIPC,SZ,TNR,CR,SOR,TNR,COR,ALIR,ALR,ALOR,
0043 *P2(10),W12(10),W1(10),TEIR,TER,TEOR,D1OR,BETAZ,BETAI,ANH,
0044 *TTR,TR,TOR,STALI(10)
0045 COMMON/ARE/REE
0046 COMMON/TRA/XP01(5,8),XP02(6,8),ALF1(8),ALF01(5),ALF02(6),
0047 *Y(10),Y1(10),Q(6),RX(30),RY(30),IR(30),Z(6),C1(4,2),C2(4,8)
0048 DATA ALF1/ 10.,15.,20.,25.,30.,40.,50.,60./
0049 DATA ALF01/ 40.,50.,60.,70.,80./
0050 DATA ALF02/ 80.,90.,100.,120.,150.,170./
0051 DATA XP01/ .0570,.0465,.0440,.0428,.0424,
0052 * .0530,.0415,.0350,.0330,.0323,
0053 * .0495,.0380,.0312,.0296,.0285,
0054 * .0475,.0355,.0295,.0267,.0250,
0055 * .0440,.0335,.0273,.0245,.0225,
0056 * .0420,.0312,.0274,.0205,.0183,
0057 * .0420,.0300,.0213,.0181,.0152,
0058 * .0420,.0300,.0206,.0155,.0125/
0059 DATA XP02/ .0424,.0422,.0420,.0402,.0313,.0000,
0060 * .0323,.0320,.0318,.0295,.0200,.0000,
0061 * .0283,.0280,.0275,.0250,.0143,.0000,
0062 * .0250,.0246,.0242,.0208,.0070,.0000,
0063 * .0225,.0216,.0203,.0168,.0000,.0000,
0064 * .0183,.0170,.0154,.0106,.0100,.0000,
0065 * .0150,.0136,.0104,.0050,-.015,.0000,
0066 * .0125,.0099,.0073,.0000,-.020,.0000/
0067 DATA VIS2,VIS3,CP,EMME,GAM/.000013,.000012,.24,28.97,1.4/
0068 DATA G,CJ,EXP1,EXP2,ERRE/32.174,778.16,3.5,.2857,53.3459/
0069 END
0070 PROGRAM THESS
0071
0072 CC
0073 DIMENSION INAM(3)
0074 COMMON/ABA/BA17,BLEX
0075 COMMON/CUR/COSL(10)
0076 COMMON/TOL/TOL1,TOL2,TOL3,TOL4
0077 COMMON/TPS/TRAS
0078 COMMON/GAS/CP,GAM,EMME,ERRE,EXP1,EXP2,VIS2,VIS3

```



```

0079 COMMON/COZ/ICOR,ICDZ,IINC,IAI,ICL,IAN,ICON
0080 COMMON/MAC/IN
0081 COMMON/IWI/IND,INZ,IWR
0082 COMMON/AUS/XCL
0083 COMMON/CSS/CJ,G,Q1
0084 COMMON/VAR1/RC(10),RSOLD2,RSOLD3,RSOLD4,ASFO,RSFO,RRFO,ARFO,
0085 *RR(10),RROLD2,RROLD3,RROLD4,CV,CK,VA1(10),DALF(10),DBET(10),
0086 *ASF,AMS,R1(20)
0087 COMMON/VAR2/H6(20),ZR,ZS,ARF,R2(20),PR,AMR,VU1(10)
0088 COMMON/VAR3/PTE(10),RS1,RS3,RS5,T2(10)
0089 COMMON/VAR4/RR1,RR2,RR3,RR1,RR3,RR5,VA2(10)
0090 COMMON/VAR5/PRA1(10),RINCI(10),ALFA1(10),BETA1(10),ZETA1(10),
0091 *U2(10),ALFA2(10),BETA2(10)
0092 COMMON/VAR6/PT2(10),TT2(10),PT1(10),DELH(10),ALFA2(10),VU2(10),
0093 *WR2(10),T2S(10),T2IS(10)
0094 COMMON/VAR7/TTIS(5),HETAT(5),ETAT(5),ETAI(10),ETAS(10),ETAR(10),
0095 *RSTAR(10),AKIS(10),PSTR(10)
0096 COMMON/VAR8/DR1(10),AMW1(10),AMV2(10),BFTFT(10),PRAT1T(10),
0097 *AMR2(10),YS(10),X1(10),AREA1(10),ZETAPS(10),WPER1(10),YR(10),
0098 *X2(10)
0099 COMMON/VAR9/ZETAR(10),ZETAPR(10),AS(10),AR(10),SI1(10),SI2(10),
0100 *S1(10),DSDX1(10),WT1(10),HE(10)
0101 COMMON/VAR10/WU1(10),DHEDX(10),DSDX2(10),RI1(10),RI2(10),
0102 *RI3(10),RJ4(10),RI(10),SR1(10),SR2(10)
0103 COMMON/VAR11/YOLD(10),AA(10),SR(10),PRAT2(10),WPER2(10),
0104 *PDWX(10),TIIS(10),PRAT3(10),SS(10),ALFA(10)
0105 COMMON/VAR12/BETA(10),DELR(10),WPERO(10),ZETAS(10),ZETAR1(20),
0106 *ZETAR3(20),ZETARS(20),R1(20),A1(20),T19(20)
0107 COMMON/VAR13/ST1(20),IRR(20),R2(20),A2(20),RINC(20),DR(10),
0108 *RFJO(10),STALII(10),AREA2(10),VR1(10)
0109 COMMON/VAR14/WLBM,PRATS,OMEG
0110 COMMON/AL1/ALFA1(10),V1(10),TTO,RPM,RS(10),SI,TNT,H,D,CI,T1(10),
0111 *P1(10),TO,TEI,ALI,RESP,XX,ANG20,AMS1(10),S,TN,C,TF,AL,SO,TNO,
0112 *CO,TEO,U(10),D11,D10,D21,D20,ANG21,ALFAX,T1,T,PTO,ALO,AMC
0113 COMMON/AL2/BETA2(10),BETA1(10),BETA0(10),W2(10),TTE(10),U2(10),
0114 *STR,INIR,HR,DZ,CIR,TIPC,SZ,TNR,CR,SOR,TNOR,COR,ALTR,ALR,ALOR,
0115 *P2(10),WU2(10),W1(10),TEIR,TER,TEOR,D1IR,D1OR,BETAZ,BETAI,ANM,
0116 *TIR,TR,TOR,STAL1(10)
0117 COMMON/ARF/REE
0118 COMMON/TRA/XPO1(5,8),XPO2(6,8),ALF1(8),ALFO1(5),ALFO2(6),
0119 *Y(10),Y1(10),Q(6),RX(30),RY(30),IR(30),Z(6),C1(4,8),C2(4,8)
0120 DATA INAM /2HSH,2HOR,2HT /
0121 TRAS=1
0122 XX=1.25
0123 CALL EXEC(8,INAM).
0124 END
0125 C
0126 SUBROUTINE CHAN(TTO,AMC,PTO,RC,WLBM,WCHAN,WPERO)
0127 DIMENSION RC(10),WPERO(10)
0128 COMMON/GAS/CP,GAM,EMME,ERKE,EXP1,EXP2,VIS2,VIS3
0129 COMMON/CSS/CJ,G,Q1
0130 TC=TTO/(1.+(GAM-1.)/2.*AMC*AMC)
0131 VC=SQRT(GAM*ERRE*G*TC)*AMC
0132 PC=PTO/(1.+(GAM-1.)*AMC**2/2.)*EXP1
0133 RHO=PC/ERRE/TC
0134 AREA=3.1416*(RC(5)**2-RC(1)**2)
0135 WLBM=RHO*AREA*VC
0136 WCHAN=WLBM/(PTO*SQRT(G/ERRE/TTO))
0137 WPERO(1)=0.
0138 WPERO(2)=.25
0139 WPERO(3)=.5
0140 WPERO(4)=.75
0141 WPERO(5)=1.0
0142 RETURN
0143 END
0144 C
0145 SUBROUTINE STATR (ALFA1,X,TTO,PTO,AM,T,P,V1,VA1,SI1,SI2,Y,S,DSDX,
0146 *VU1,PRAT,TIIS,SS,DALF,RSF,DELR,CL,CK,ZFTAPS,R,RS1,RS3,RSS,
0147 *ZETA,DR,ZETAS,AMS,NS,VR1)
0148 DIMENSION ALFA1(10),X(10),T(10),P(10),V1(10),VA1(10),SI1(10),
0149 *SI2(10),Y(10),DSDX(10),VU1(10),PRAT(10),TIIS(10),SS(10),S(10),
0150 *DALDX(10),ALFA(10),ALFAM(10),DALF(10),AMS(10),DALFDX(10),DELR(
0151 *10),ZETAS(10),ETA(10),ZETAPS(10),R(10),ZETA(10),DR(10),VR1(10)
0152 COMMON/GAS/CP,GAM,EMME,ERKE,EXP1,EXP2,VIS2,VIS3
0153 COMMON/CSS/CJ,G,Q1
0154 COMMON/IWI/IND,INZ,IWR
0155 C8=0.0
0156 C9=0.0
0157 Q1=2.*CJ*G*CP
0158 C2=VA1(3)**2/(Q1*TTO)

```



```

0159      DO 303 I=1,5
0160      IF(R(I)-RS3) 300,301,302
0161 300 ZETAS(I)=ZETA(1)+((R(I)-RS1)/(RS3-RS1))*(ZETA(3)-ZETA(1))
0162      ALFA1(I)=ALFA1(3)+((R(I)-RS3)/(RS1-RS3))*DALF(1)
0163      ZETAPS(I)=ZETAPS(1)+((R(I)-RS1)/(RS3-RS1))*(ZETAPS(3)-ZETAPS(1))
0164      GO TO 303
0165 301 ZETAS(I)=ZETA(3)
0166      ALFA1(I)=ALFA1(3)
0167      GO TO 303
0168 302 ZETAS(I)=ZETA(3)+((R(I)-RS3)/(RS5-RS3))*(ZETA(5)-ZETA(3))
0169      ALFA1(I)=ALFA1(3)+((R(I)-RS3)/(RS5-RS3))*DALF(5)
0170      ZETAPS(I)=ZETAPS(3)+((R(I)-RS3)/(RS5-RS3))*(ZETAPS(5)-ZETAPS(3))
0171 303 CONTINUE
0172      DO 305 I=1,5
0173      ETA(I)=1.-ZETAS(I)
0174      M=I-1
0175      N=I+1
0176      IF(I-1) 307,307,309
0177 307 DALFDX(1)=(ALFA1(2)-ALFA1(1))/(X(2)-X(1))
0178      GO TO 315
0179 309 IF(I-5) 311,313,313
0180 311 DALFDX(I)=.5*((ALFA1(N)-ALFA1(I))/(X(N)-X(I))+(ALFA1(I)-ALFA1(M))/
0181      *(X(I)-X(M)))
0182      GO TO 315
0183 313 DALFDX(5)=(ALFA1(5)-ALFA1(4))/(X(5)-X(4))
0184 315 TAN1=-2.*TAN(ALFA1(I))
0185      PROD=TAN1*DALFDX(I)
0186      SINSQ=-2.*SIN(ALFA1(I))*2/X(I)
0187      SI1(I)=PROD+SINSQ
0188 305 CONTINUE
0189 304 DO 332 J=1,5
0190      IF(J-1) 306,306,310
0191 306 IF(NS-1) 317,310,310
0192 317 DO 308 I=1,5
0193      SS(I)=0.
0194 308 SI2(I)=SI1(I)
0195      GO TO 318
0196 310 DO 312 I=1,5
0197      AA=C2*Y(I)**2/COS(ALFA1(I))**2
0198      AB=(1.-AA)/(1.-AA/ETA(I))
0199 312 S(I)=ALOG(AB)
0200 314 DSDX(1)=(S(2)-S(1))/(X(2)-X(1))
0201      DSDX(2)=.5*(DSDX(1)+(S(3)-S(2))/(X(3)-X(2)))
0202      DSDX(3)=.5*((S(4)-S(3))/(X(4)-X(3))+(S(3)-S(2))/(X(3)-X(2)))
0203      DSDX(4)=.5*((S(5)-S(4))/(X(5)-X(4))+(S(4)-S(3))/(X(4)-X(3)))
0204      DSDX(5)=(S(5)-S(4))/(X(5)-X(4))
0205      DO 316 I=1,5
0206      IF(NS-1) 319,321,321
0207 319 SS(I)=(1.-COS(ALFA1(I))**2/(C2*Y(I)**2))*DSDX(I)
0208      GO TO 316
0209 321 SS(I)=((-COS(ALFA1(I))**2/(C2*Y(I)**2))+SIN(ALFA1(I))**2+COS(AL
0210      *FA1(I))**2*(CL**2+(DR(I)/2.0)**2)/CL**2)*DSDX(I)+COS(ALFA1(I))**2*
0211      *CK**2.*RSF*DELRI/CL**2
0212 316 SI2(I)=SS(I)+SI1(I)
0213 318 SUM1=(SI2(1)+SI2(2))*(X(2)-X(1))/4.
0214      SUM2=(SI2(2)+SI2(3))*(X(3)-X(2))/4.
0215      SUM3=(SI2(3)+SI2(4))*(X(4)-X(3))/4.
0216      SUM4=(SI2(4)+SI2(5))*(X(5)-X(4))/4.
0217      EN2=-SUM2
0218      EN1=-SUM2-SUM1
0219      EN3=SUM3
0220      EN4=SUM3+SUM4
0221      Y(2)=EXP(EN2)
0222      Y(1)=EXP(EN1)
0223      Y(4)=EXP(EN3)
0224      Y(3)=1.0
0225      Y(5)=EXP(EN4)
0226      IF(IND-1) 332,323,323
0227 323 IF(J-1) 324,324,320
0228 320 IF(J-3) 322,324,322
0229 322 IF(J-5) 332,324,332
0230 324 WRITE(6,326)
0231 326 FORMAT (/57H SLINE C8 C9 ITERATION I'ALFA I'DSDX I'TOTAL
0232      * Y)
0233      DO 330 I=1,5
0234 328 FORMAT (I4,F4.2,F4.2,I9,F12.4,F9.5,F9.4,2F8.4)
0235 330 WRITE(6,328) I,C8,C9,J,SI1(I),SS(I),SI2(I),Y(1),ALFA1(I)
0236 332 CONTINUE
0237      DO 334 I=1,5
0238      VA1(I)=VA1(3)*Y(I)

```



```

0239      VU1(I)=VA1(I)*TAN(ALFA1(I))
0240      V1(I)=VA1(I)/COS(ALFA1(I))
0241      VR1(I)=-VA1(I)*DR(I)/2./CL
0242      V1(I)=SQRT(V1(I)*V1(I)+VR1(I)*VR1(I))
0243      T(I)=TTO-V1(I)**2/O1
0244      T1IS(I)=TTO-(TTO-T(I))/ETA(I)
0245      P(I)=PTO*(T1IS(I)/TTO)**EXP1
0246      334 PRA1(I)=P(I)/PTO
0247      336 DO 352 I=1,5
0248      AMS(I)=V1(I)/SQRT(GAM*ERRE*G*T(I))
0249      352 CONTINUE
0250      356 RETURN
0251      END
C
0252      SUBROUTINE ROTO1 (VU1,VA1,RPM,U,BETA1,HE,TTE,PTF,X2,P1,T1,W1,WU1,
0253      *X1,RS,ZETAR,ZETAPR,RR,DHEDX,DSDX,S,U2,OMEG,RR1,RR2,RR3,FS1,FS2,
0254      *ZETA,R6,RS1,RS3,RS5,BETO,STALI,RINC,VR1)
0255      DIMENSION VU1(5),VA1(5),U(5),BETA1(5),HE(5),TTE(5),PTE(5),
0256      *X2(5),P1(5),T1(5),W1(5),WU1(5),X1(5),RS(5),ZETAR(5),
0257      *ZETAPR(5),RR(5),DHEDX(5),DSDX(5),S(5),U2(5),ZETA(5),
0258      *VR1(5),R6(10),BETO(5),STALI(5),RINC(5)
0259      COMMON/CSS/CJ,G,Q1
0260      COMMON/GAS/CP,GAM,EMME,ERRE,EXP1,EXP2,VIS2,VIS3
0261      COMMON/IWI/IND,INZ,IWR
0262      C=2.*32.174*778.16*CP
0263      OMEG=RPM*3.1416/30.
0264      DO 520 I=1,5
0265      U(I)=OMEG*RS(I)/12.
0266      U2(I)=U(I)*RR(I)/RS(I)
0267      WU1(I)=VU1(I)-U(I)
0268      BETA1(I)=ATAN(WU1(I)/VA1(I))
0269      W1(I)=VA1(I)/COS(BETA1(I))
0270      W1(I)=SQRT(VR1(I)*VR1(I)+W1(I)*W1(I))
0271      TTF(I)=T1(I)+W1(I)**2/C+(U2(I)**2-U(I)**2)/C
0272      PTE(I)=P1(I)*(TTE(I)/T1(I))**EXP1
0273      HE(I)=TTE(I)*.24
0274      IF(RS(I)-RS3) 512,514,516
0275      512 ZETAR(I)=ZETA(I)+(RS(I)-RS1)/(RS3-RS1)*(ZETA(3)-ZETA(1))
0276      GO TO 518
0277      514 ZETAR(I)=ZETA(3)
0278      GO TO 518
0279      516 ZETAR(I)=ZETA(3)+(RS(I)-RS3)/(RS5-RS3)*(ZETA(5)-ZETA(3))
0280      ZETAPR(I)=ZETAR(I)/2.0
0281      520 CONTINUE
0282      DSDX(1)=(S(2)-S(1))/(X2(2)-X2(1))
0283      DSDX(2)=.5*(DSDX(1)+(S(3)-S(2))/(X2(3)-X2(2)))
0284      DSDX(3)=.5*(S(4)-S(3))/(X2(4)-X2(3))+.5*(S(3)-S(2))/(X2(3)-X2(2))
0285      DSDX(4)=(S(5)-S(4))/(X2(5)-X2(4))
0286      DSDX(5)=.5*(DSDX(4)+(S(4)-S(3))/(X2(4)-X2(3)))
0287      DHEDX(1)=(HE(2)-HE(1))/(X2(2)-X2(1))
0288      DHEDX(2)=.5*(DHEDX(1)+(HE(3)-HE(2))/(X2(3)-X2(2)))
0289      DHEDX(3)=.5*(DHEDX(2)+(HE(4)-HE(3))/(X2(4)-X2(3)))
0290      DHEDX(4)=.5*(DHEDX(3)+(HE(5)-HE(4))/(X2(5)-X2(4)))
0291      DHEDX(5)=.5*(DHEDX(4)+(HE(4)-HE(3))/(X2(4)-X2(3)))
0292      522 CONTINUE
0293      RETURN
0294      END
C
0295      SUBROUTINE ROTO2 (BETA2,HE,DHEDX,DSDX1,DSDX2,VA2,WU2,W2,VU2,U2,
0296      *X2,U,YR,ZETAR,RI1,RI2,RI3,RI4,RI,SR1,SR2,AA,SR,TTE,PTF,T2,P2,PRAT2
0297      *T2S,INDS,DBET,KRF,DELK,CL,CK,DR,R,RR1,RR3,RRS,NS,WR2)
0298      DIMENSION BETA2(5),HE(5),DHEDX(5),DSDX1(5),DSDX2(5),VA2(5),
0299      *WU2(5),W2(5),VU2(5),U2(5),X2(5),U(5),YR(5),ZETAR(5),
0300      *RI1(5),RI2(5),RI3(5),RI4(5),RI(5),SR1(5),SR2(5),YOLD(5),
0301      *AA(5),SR(5),TTE(5),PTF(5),T2(5),P2(5),PRAT2(5),T2S(5),
0302      *DBET(5),BETAM(5),AMR(5),DBETDX(5),BETA(5),DELK(5),RIS(5),
0303      *DR(5),R(5),WR2(5)
0304      COMMON/TOL/TOL1,TOL2,TOL3,TOL4
0305      COMMON/CSS/CJ,G,Q1
0306      COMMON/GAS/CP,GAM,EMME,ERRE,EXP1,EXP2,VIS2,VIS3
0307      COMMON/IWI/IND,INZ,IWR
0308      INDS=0
0309      INDS1=0
0310      C=2.*G*CP
0311      Q1=C/VA2(3)**2
0312      DO 274 I=1,5
0313      IF(K(I)-RR3) 270,271,273
0314      270 BETA2(I)=BETA2(3)+(R(I)-RR3)/(RR1-RR3)*DBET(1).
0315      GO TO 274

```





```

0319 271 BETA2(I)=BETA2(3)
0320 GO TO 274
0321 273 BETA2(I)=BETA2(3)+(R(I)-RR3)/(RR5-RR3)*DBET(5)
0322 274 CONTINUE
0323 DBETDX(I)=(BETA2(2)-BETA2(1))/(X2(2)-X2(1))
0324 DBETDX(5)=(BETA2(5)-BETA2(4))/(X2(5)-X2(4))
0325 DO 280 I=2,4
0326 M=I-1
0327 N=I+1
0328 280 DBETDX(I)=.5*((BETA2(N)-BETA2(I))/(X2(N)-X2(I))+(BETA2(I)-BETA2
0329 *(M))/(X2(I)-X2(M)))
0330 DO 10 I=1,5
0331 200 TAN1=-2.*TAN(BETA2(I))
0332 PROD=TAN1*DBETDX(I)
0333 SIN1=-2.*SIN(BETA2(I))*2/X2(I)
0334 RI1(I)=PROD+SIN1+DSDX1(I)
0335 SR1(I)=-4.*U(3)*COS(BETA2(I))*SIN(BETA2(I))/(UA2(3)*YR(I))
0336 SR2(I)=2.*U(3)*U(I)*COS(BETA2(I))*2/(UA2(3)**2*YR(I)**2)
0337 YOLD(I)=YR(I)
0338 AA(I)=(UA2(3)*YR(I)/COS(BETA2(I)))*2/(C*HE(I))
0339 RI3(I)=(C*COS(BETA2(I)))*2/((UA2(3)*YR(I))**2)*DHEDX(I)
0340 TF (INDS1-1) 10,250,250
0341 10 CONTINUE
0342 281 IF(IND-1) 201,282,282
0343 282 WRITE(6,121)(RI1(I),I=1,5)
0344 121 FORMAT(/23H CONSTANT INTEGRAND 1-5, SF8.5)
0345 WRITE (6,122)
0346 122 FORMAT(/60H SLINE INDS1 GRAD S INT2 INT3 INT4 INT
0347 *Y VAL)
0348 201 DO 20 J=1,13
0349 DO 30 I=1,5
0350 AA(I)=AA(I)*(YR(I)/YOLD(I))**2
0351 ANUM=1.-AA(I)
0352 ADEN=1.-AA(I)/(1.-ZETAR(I))
0353 AR=ANUM/ADEN
0354 TF (AR) 130,130,30
0355 130 INDS=1
0356 GO TO 150
0357 30 SR(I)=ALOG(ANUM/ADEN)
0358 DSDX2(1)=(SR(2)-SR(1))/(X2(2)-X2(1))
0359 DSDX2(2)=0.5*(DSDX2(1)+(SR(3)-SR(2))/(X2(3)-X2(2)))
0360 DSDX2(3)=0.5*(SR(3)-SR(2))/(X2(3)-X2(2))+(SR(4)-SR(3))/
0361 *(X2(4)-X2(3))
0362 DSDX2(5)=(SR(5)-SR(4))/(X2(5)-X2(4))
0363 DSDX2(4)=0.5*(DSDX2(5)+(SR(4)-SR(3))/(X2(4)-X2(3)))
0364 DO 40 I=1,5
0365 SR1(I)=SR1(I)*YOLD(I)/YR(I)
0366 SR2(I)=SR2(I)*(YOLD(I)/YR(I))**2
0367 RI2(I)=SR1(I)-SR2(I)
0368 RI3(I)=RI3(I)*(YOLD(I)/YR(I))**2
0369 IF(NS-1) 31,32,32
0370 31 RI4(I)=DSDX2(I)-(DSDX1(I)+DSDX2(I))*C1*HE(I)
0371 * *(COS(BETA2(I))/YR(I))**2
0372 GO TO 40
0373 32 RI4(I)=- (DSDX1(1)+DSDX2(I))*C1*HE(I)*(COS(BETA2(I))/YR(I))**2
0374 RI5(I)=(DSDX1(I)+DSDX2(I))* (SIN(BETA2(I))**2+COS(BETA2(I))**2
0375 **((CL**2+(DR(I)/2.0)**2)/CL**2))-COS(BETA2(I))**2*(2.*CK*RRF*
0376 *DEL(I))/CL**2
0377 RI4(I)=RI4(I)+RI5(I)
0378 40 RI(I)=RI1(I)+RI2(I)+RI3(I)+RI4(I)
0379 SUM1=(RI(1)+RI(2))*(X2(2)-X2(1))/4.
0380 SUM2=(RI(2)+RI(3))*(X2(3)-X2(2))/4.
0381 SUM3=(RI(3)+RI(4))*(X2(4)-X2(3))/4.
0382 SUM4=(RI(4)+RI(5))*(X2(5)-X2(4))/4.
0383 EN1=-(SUM2-SUM1)
0384 EN2=-SUM2
0385 EN4=SUM3
0386 EN5=SUM3+SUM4
0387 DO 50 I=1,5
0388 50 YOLD(I)=YR(I)
0389 YR(1)=EXP(EN1)
0390 YR(2)=EXP(EN2)
0391 YR(3)=1.0
0392 YR(4)=EXP(EN4)
0393 YR(5)=EXP(EN5)
0394 NCOUNT=0
0395 DO 1001 I=1,5
0396 IF(YR(I).GT.2.0) YR(I)=2.0
0397 IF(YR(I).LT.0.2) YR(I)=0.2
0398 1001 CONTINUE

```



```

0399      DO 110 I=1,5
0400      TEST=ABS(YO1D(I)-YR(I))
0401      IF (TEST-TOL4) 110,110,119
0402      NCOUNT=NCOUNT+1
0403      IF (NCOUNT-5) 119,140,119
0404      119 IF (IND-1) 20,120,120
0405      120 IF (J-3) 80,100,30
0406      80 IF (J-6) 90,100,90
0407      90 IF (J-9) 150,100,160
0408      160 IF (J-12) 20,100,20
0409      100 DO 60 I=1,5
0410      123 FORMAT (I4,I7,F10.5,5F8.4)
0411      60 WRITE (6,123) I,INDS1,DSDX2(I),RI2(I),RI3(I),RJ4(I),RI(I),YR(I)
0412      20 CONTINUE
0413      140 DO 70 I=1,5
0414      VA2(I)=YR(I)*VA2(3)
0415      W2(I)=VA2(I)/COS(BETA2(I))
0416      WR2(I)=-VA2(I)*DR(I)/2./CL
0417      W2(I)=SQRT(W2(1)*W2(I)+WR2(I)*WR2(I))
0418      70 T2(I)=TTE(I)-W2(I)**2/(0.24*C)
0419      IF (INDS1-1) 251,149,149
0420      251 INDS1=INDS1+1
0421      DO 250 I=1,5
0422      AMR(I)=W2(I)/SQRT(GAM*ERRE*G*T2(I))
0423      250 CONTINUE
0424      149 DO 190 I=1,5
0425      WU2(I)=VA2(I)*TAN(BETA2(I))
0426      VU2(I)=WU2(I)+U(I)
0427      T2S(I)=TTE(I)-(TTE(I)-T2(I))/(1.-ZETAR(I))
0428      P2(I)=PTE(I)*(T2S(I)/TTE(I)**(GAM/(GAM-1.)))
0429      PRAT2(I)=P2(I)/PTE(I)
0430      190 CONTINUE
0431      150 RETURN
0432      END
0433 C
0434      SUBROUTINE FLOWR (PRAT, ZETAP, X, WI, PTE, PTO, TTE, TTO, AS, ZS, RS, AR, ZR,
0435      *RR, M, WCHAN, UA, WPER, CODE, WLRM, B, R, TIPC, A)
0436      DIMENSION PRAT(10), ZETAP(10), X(10), WI(10), PTE(10), TTE(10),
0437      *VA(10), WPER(10), B(20), A(10), R(10)
0438      COMMON/CUR/COSL(10)
0439      COMMON/TOL/TOL1, TOL2, TOL3, TOL4
0440      COMMON/MAC/IN
0441      COMMON/GAS/CP, GAM, EMME, ERRE, EXP1, EXP2, VIS2, VIS3
0442      COMMON/CSS/CJ, G, Q1
0443      COMMON/ARA/RA17, BLEX
0444      COMMON/IWI/IND, INZ, IWR
0445      IN=20
0446      C=BLEX
0447      A(3)=B(1)+B(2)*R(3)+B(3)*R(3)**2+B(4)*R(3)**3+B(5)*R(3)**4
0448      F1=1./(C+1.)
0449      F2=1./(3.*C+1.)
0450      F3=1./(5.*C+1.)
0451      F4=1./(7.*C+1.)
0452      F5=1./(9.*C+1.)
0453      F6=1./(11.*C+1.)
0454      PRATCR=(2./(GAM+1.))*((GAM/(GAM-1.)))
0455      PHICR=(2./(GAM+1.))*((1./(GAM-1.))*SQRT(2.*GAM/(GAM+1.)))
0456      DO 420 I=1,5
0457      IF (PRATCR-PRAT(I)) 400,402,402
0458      400 XE=1.-PRAT(I)**((GAM-1.)/GAM)
0459      GO TO 404
0460      402 XF=1.-PRATCR**((GAM-1.)/GAM)
0461      404 XF2=XE**2
0462      XF3=XE**3
0463      XF4=XE**4
0464      XFINV=1./(XE-1.)
0465      HNUM=XFINV+F2+XF*F3+XF2*F4+XF3*F5+XF4*F6
0466      HDEN=XFINV+F1+XF*F2+XF2*F3+XF3*F4+XF4*F5
0467      HSTAR=HNUM/HDEN
0468      XI=(HSTAR-1.)/(HSTAR-1.+ZETAP(I))
0469      IF (PRATCR-PRAT(I)) 406,408,408
0470      406 PHI=SQRT(2.*GAM/(GAM-1.))*(PRAT(I)**(2./GAM)-PRAT(I)**
0471      *((GAM+1.)/GAM))
0472      GO TO 410
0473      408 PHI=PHICR
0474      410 A(I)=B(1)+B(2)*R(I)+B(3)*R(I)**2+B(4)*R(I)**3+B(5)*R(I)**4
0475      ARAT=A(I)/A(3)
0476      IF (M-2) 415,412,415
0477      412 TF(I-5) 415,414,414
0478      414 ARAI=ARAT+2.*3.1416*R(5)*TIPC/(7R*AR*FR*(X(5)-X(4)))

```



```

0479 415 IF(IND-1) 420,416,416
0480 416 WRITE(6,418) XI,PHI,ARAT
0481 419 FORMAT(/5H XH=,F6.4,6H PHI=,F7.5,7H ARAT=,F6.4)
0482 420 WI(1)=(PTE(I)/PT0)/SQRT(TTE(I)/T0)*ARAT*XI*PHI*COSL(I)
0483 SUM1=(WI(1)+WI(2))*(X(2)-X(1))/2.
0484 SUM2=(WI(2)+WI(3))*(X(3)-X(2))/2.
0485 SUM3=(WI(3)+WI(4))*(X(4)-X(3))/2.
0486 SUM4=(WI(4)+WI(5))*(X(5)-X(4))/2.
0487 WSUM=SUM1+SUM2+SUM3+SUM4
0488 IF(M-1) 428,426,428
0489 426 WREQ=WCHAN/(AS*ZS*RS)
0490 DIFF=ABS(WREQ-WSUM)
0491 GO TO 430
0492 428 WREQ=WCHAN/(AR*ZR*RR)
0493 DIFF=ABS(WREQ-WSUM)
0494 430 TAL=TOL1*WREQ
0495 IF (DIFF-TAL) 432,432,434
0496 432 VA(3)=VA(3)
0497 CODE=20.
0498 GO TO 442
0499 434 IF(WSUM-WREQ) 436,432,438
0500 436 CONTINUE
0501 IF(PRAT(1),LT,PRATCR,AND,PRAT(5),LT,PRATCR) GO TO 470
0502 VA(3)=VA(3)*(1.00+DIFF/WREQ*1.01)
0503 GO TO 442
0504 438 VA(3)=VA(3)*(1.00-DIFF/WREQ*1.01)
0505 442 WPER(1)=0.
0506 WPER(2)=SUM1/WSUM
0507 WPER(3)=(SUM1+SUM2)/WSUM
0508 WPER(4)=(SUM1+SUM2+SUM3)/WSUM
0509 WPER(5)=1.0
0510 IF(IND-1) 450,423,423
0511 423 WRITE(6,422) (WI(I),I=1,5)
0512 422 FORMAT(/20H FLOW INTEGRAND 1-5, F10.5)
0513 424 WRITE(6,424) SUM1,SUM2,SUM3,SUM4,WSUM
0514 424 FORMAT(/15H Sums 1-4, WSUM, SF10.5)
0515 WRITE(6,440) WSUM,WREQ,VA(3)
0516 440 FORMAT(35H REF FLOWS,COMPUTED-REQUIRED,AX VAL,2F10.4,F10.2)
0517 WRITE(6,444) WCHAN,WLEM
0518 444 FORMAT(/36H REF FLOW RATE CHANNEL-SQUARE INCHES,F8.5,18H FLOW RATE
0519 *LBM/SEC,FR,5)
0520 WRITE(6,446) M
0521 446 FORMAT(/30H STREAMLINE FLOW FRACTIONS, M=12)
0522 WRITE(6,448) X(2),WPER(2),X(3),WPER(3),X(4),WPER(4)
0523 448 FORMAT(6F10.4)
0524 GO TO 450
0525 470 IN=1
0526 450 RETURN
0527 END

```

C

```

0528 SUBROUTINE SLINE (RR,X,DWDX,WPER2,WPER1,HF,U,DHEDX,S,DSDX1,
0529 *ARF,RRF,FC1,FC2,CODE,M,B)
0530 DIMENSION RR(10),X(10),DWDX(10),WI(10),WPER2(10),WPER1(10),HE(10),
0531 *DHEDX(10),S(10),DSDX1(10),U(10),B(20)
0532 COMMON/TOL/TOL1,TOL2,TOL3,TOL4
0533 COMMON/IWI/IND,INZ,IWR
0534 N7=0
0535 SAVE=RR(3)
0536 CODE=1.
0537 DO 700 I=1,4
0538 J=I+1
0539 700 DWDX(I)=(WPER2(J)-WPER2(I))/(X(J)-X(I))
0540 N=0
0541 DO 720 I=2,4
0542 K=I+1
0543 J=I-1
0544 IF (ABS(WPER2(I)-WPER1(I))-TOL2) 716,716,702
0545 702 IF (WPER2(I)-WPER1(I)) 704,716,708
0546 704 XN=X(1)+(WPER1(I)-WPER2(I))/DWDX(J)
0547 IF(M-1) 706,712,706
0548 706 SL=(HE(K)-HE(I))/(X(K)-X(I))
0549 DEL=2.*(SL-DHEDX(I))/(X(K)-X(I))
0550 DHEDX(I)=DHEDX(I)+DF1*(XN-X(I))
0551 HE(I)=HE(I)+DHEDX(I)*(XN-X(I))
0552 SL=(S(K)-S(I))/(X(K)-X(I))
0553 DEL=2.*(SL-DSDX1(I))/(X(K)-X(I))
0554 DSDX1(I)=DSDX1(I)+DF1*(XN-X(I))
0555 S(I)=S(I)+DSDX1(I)*(XN-X(I))
0556 GO TO 712
0557 708 XN=X(1)-(WPER2(I)-WPER1(I))/DWDX(I)

```



```

0559 IF (M-1) 710,712,710
0560 710 SI=(HE(I)-HF(J))/(X(I)-X(J))
0561 DEL=2.*(DHFDX(I)-SI)/(X(I)-X(J))
0562 DHFDX(I)=DHFDX(I)+DEL*(XN-X(I))
0563 HE(I)=HE(I)+DHEDX(I)*(XN-X(I))
0564 SL=(S(I)-S(J))/(X(I)-X(J))
0565 DEL=2.*(DSDX1(I)-SL)/(X(I)-X(J))
0566 DSDX1(I)=DSDX1(I)+DEL*(SN-X(I))
0567 S(I)=S(I)+DSDX1(I)*(XN-X(I))
0568 712 RR(I)=XN*SAVE
0569 GO TO 718
0570 716 N=N+1
0571 IF (N-3) 720,730,720
0572 718 U(I)=U(I)*XN/X(I)
0573 720 CONTINUE
0574 DO 722 I=1,5
0575 722 X(I)=RR(I)/RR(3)
0576 FC1=RR(3)/SAVE
0577 FC2=FC1**2
0578 RRF=RR(3)
0579 ARF=R(1)+R(2)*RRF+B(3)*RRF**2+B(4)*RRF**3+B(5)*RRF**4
0580 IF (IND-1) 732,721,721
0581 721 JF (M-1) 729,732,729
0582 729 WRITE (6,724)
0583 724 FORMAT (/47H SLINE XNEW HENEW DHEDX S-NEW DSDX1)
0584 DO 728 I=1,5
0585 726 FORMAT (I4,F9.4,F9.2,F9.4,F9.6,F9.5)
0586 728 WRITE (6,726) I,X(I),HE(I),DHEDX(I),S(I),DSDX1(I)
0587 GO TO 732
0588 730 CODE=40.
0589 732 RETURN
0590 END
0591 C
0592 SUBROUTINE ALOS1(ZETAS,ZETAPS)
0593 DIMENSION ZETAS(10),ZETAPS(10)
0594 COMMON/AL1/ALFA1(10),V1(10),TTO,RPM,RS(10),SI,TNI,H,D,CI,T1(10),
0595 *P1(10),TO,TEI,ALI,RESP,XX,ANG20,AMS1(10),S,TN,C,TE,AL,SO,TNO,
0596 *CO,TEU,U(10),D11,D10,D21,D20,ANG21,ALFAX,T11,PTO,ALO,AMC
0597 COMMON/AL2/BETA2(10),BETA1(10),BETA0(10),W2(10),TTE(10),U2(10),
0598 *STR,TNR,HR,DZ,CIR,TIPC,SZ,TNR,CR,SOR,TNOR,COR,ALIR,ALR,ALOR,
0599 *P2(10),WU2(10),W1(10),TEIR,TEF,TEOR,DIR,DIOR,BETAZ,BETA1,ANM,
0600 *TIR,TR,TOR,STALI(10)
0601 COMMON/GAS/CP,GAM,EMME,ERKE,EXP1,EXP2,VIS2,VIS3
0602 COMMON/CSS/CJ,G,Q1
0603 COMMON/IWI/IND,INZ,IWR
0604 COMMON/AUS/XCL
0605 COMMON/ARE/REE
0606 COMMON/COZ/ICOR,ICOZ,IINC,IAI,ICL,IAN,ICON
0607 COMMON/ARA/RA17,BLEX
0608 COMMON/TRS/TRAS
0609 DO 6001 MACC=1,5,2
0610 TRA1=90.-ALFA1(MACC)*57.29578
0611 TRA2=V1(MACC)*.3048
0612 TRA3=TTO/1.8
0613 TRA4=RPM*3.14159/30.*RS(MACC)/12.*.3048
0614 IF(MACC-3) 6002,6003,6004
0615 6002 CALL TRAU2 (TRA1,90.,TRA2,TRA3,EMME,GAM,SI,TNI,H,D,TRAS,CI,TRA4,
0616 *0.,TR15,TRA7,TRAB,TRA9,ZETAS(MACC))
0617 GO TO 6001
0618 6003 CALL TRAU2 (TRA1,90.,TRA2,TRA3,EMME,GAM,S,TN,H,D,TRAS,C,TRA4,
0619 *0.,TR26,TRA7,TRAB,TRA9,ZETAS(MACC))
0620 GO TO 6001
0621 6004 CALL TRAU2 (TRA1,90.,TRA2,TRA3,EMME,GAM,SO,TNO,H,D,TRAS,CO,TRA4,
0622 *0.,TR36,TRA7,TRAB,TRA9,ZETAS(MACC))
0623 6001 CONTINUE
0624 IF(ICOZ.I.T.5) GO TO 2026
0625 DO 2027 MACC=1,5,2
0626 XY=ZETAS(MACC)/(1.-ZETAS(MACC))
0627 ZETAS(MACC)=(((1.+XY)/(1.+XY*P1(MACC)/PTO))**EXP2-1.)/
0628 *((PTO/P1(MACC))**EXP2-1.)
0629 IF(ICOZ.FQ.8) ZETAS(MACC)=(((1.+XY)/(1.+XY*BESP))**EXP2-1.)/
0630 *(1./BESP**EXP2-1.)
0631 2027 CONTINUE
0632 2026 CONTINUE
0633 IF(ICON.NE.3) GO TO 31
0634 30 DO 32 I=1,5,2
0635 32 ZETAPS(I)=ZETAS(I)
0636 31 IF(ICON.NE.2) GO TO 33
0637 IF(ICOR.FQ.4) ZETAPS(1)=TR16
0638 IF(ICOR.FQ.4) ZETAPS(3)=TR26

```





```

0639      JF(ICOR.EQ.4) ZETAPS(5)=TR36
0640      33 CONTINUE
0641      JF(ICON.NE.1) GO TO 34
0642      DO 35 I=1,5,2
0643      ZETAPS(I)=.5*ZETAS(I)
0644      34 CONTINUE
0645      DO 66 K=1,5
0646      66 CONTINUE
0647      RETURN
0648      END
0649
C
0650      SUBROUTINE ALOS2(ZETAR,ZETAPR)
0651      DIMENSION ZETAPS(10),ZETAS(10),ZETAPR(10),ZETAR(10)
0652      COMMON/AL1/ALFA1(10),V1(10),TTO,RPM,RS(10),SI,TNI,H,D,CI,T1(10),
0653      *P1(10),TO,TEI,ALI,BESP,XX,ANG20,AMBI(10),S,TN,C,TF,AL,SO,TNO,
0654      *CO,IEQ,U(10),D11,D10,D21,D20,ANG21,ALFAX,TI,T,PTO,ALO,AMC
0655      COMMON/AL2/BETA2(10),BETA1(10),BETA0(10),W2(10),TTE(10),U2(10),
0656      *SIR,TNIR,HR,DZ,CIR,TIPC,SZ,TNR,CR,SOR,TNOR,COR,ALIR,ALK,ALOR,
0657      *P2(10),WU2(10),W1(10),TEIR,TER,TEOR,D1TR,D1OR,BETAZ,BETA1,ANM,
0658      *TTR,TR,TOR,STAL(10)
0659      COMMON/VAR1/RC(10),RSOLD2,RSOLD3,RSOLD4,ASFO,RSFO,RRFO,ARFO,
0660      *RR(10),RROLD2,RROLD3,RROLD4,CV,CK,VA1(10),DALF(10),DBET(10),
0661      *ASF,AMS,R1(20)
0662      COMMON/VAR2/R6(20),ZR,ZS,ARF,R2(20),PR,AMR
0663      COMMON/VAR3/PTE(10),RS1,RS3,RS5,T2(10)
0664      COMMON/VAR4/RR1,RR2,RR3,RR1,RR3,RR5,VA2(10)
0665      COMMON/AHA/BA17,BLEX
0666      COMMON/GAS/CP,GAM,EMME,ERRE,EXP1,EXP2,VIS2,VIS3
0667      COMMON/CSS/CJ,G,Q1
0668      COMMON/IWI/IND,INZ,IWR
0669      COMMON/AUS/XCL
0670      COMMON/ARE/REE
0671      COMMON/COZ/ICOR,ICOZ,IINC,IAI,ICL,IAN,ICON
0672      COMMON/TR5/TRAS
0673      IF(ICOR.NE.4) GO TO 6010
0674      DO 6011 MACC=1,5,2
0675      TRA1=90.+BETA2(MACC)*57.29578
0676      TRAX=90.-BETA1(MACC)*57.29578
0677      GIUD=BETA0(MACC)-BETA1(MACC)
0678      IF(IINC.EQ.1.AND.GIUD.GE.0.) TRAX=90.-BETA0(MACC)*57.29578
0679      TRA2=W2(MACC)*.3048
0680      TRA3=TTE(MACC)/1.8
0681      TRA4=U2(MACC)*.3048
0682      IF(MACC=3) 6012,6013,6014
0683      6012 CALL TRAU2 (TRA1,TRAX,TRA2,TRA3,EMME,GAM,SIR,TNIR,HR,DZ,TRAS,CIR,
0684      *TRA4,TIPC,TR16,TRA7,TRAB,TRA9,ZETAR(MACC))
0685      GO TO 6011
0686      6013 CALL TRAU2 (TRA1,TRAX,TRA2,TRA3,EMME,GAM,SZ,TNR,HR,DZ,TRAS,CR,
0687      *TRA4,TIPC,TR26,TRA7,TRAB,YCL,ZETAR(MACC))
0688      GO TO 6011
0689      6014 CALL TRAU2 (TRA1,TRAX,TRA2,TRA3,EMME,GAM,SOR,TNOR,HR,DZ,TRAS,COR,
0690      *TRA4,TIPC,TR36,TRA7,TRAB,TRA9,ZETAR(MACC))
0691      6011 CONTINUE
0692      DH1=CP*TTO*(1.-(P2(3)/PTO)**EXP2)
0693      PSI=1./((1.-YCL*DH1*G*CJ/U2(3)/WU2(3))
0694      ZEZE=ZETAR(3)
0695      DO 6015 MACC=1,5,2
0696      ZETAR(MACC)=ZETAR(MACC)+(1.-ZEZE)*(1.-PSI*PSI)
0697      6015 CONTINUE
0698      6010 CONTINUE
0699      JF(ICOZ.LT.5) GO TO 2046
0700      DO 2047 MACC=1,5
0701      XY=ZETAR(MACC)/(1.-ZETAR(MACC))
0702      ZETAR(MACC)=(((1.+XY)/(1.+XY*P2(MACC)/PTE(MACC))**EXP2-1.)/
0703      *((PTE(MACC)/P2(MACC))**EXP2-1.))
0704      IF(ICOZ.EQ.8) ZETAR(MACC)=(((1.+XY)/(1.+XY*BESP))**EXP2-1.)/
0705      *(1./BESP**EXP2-1.)
0706      2046 CONTINUE
0707      2047 CONTINUE
0708      IF(ICON.NE.3) GO TO 31
0709      DO 32 I=1,5,2
0710      ZETAPR(I)=ZETAR(I)
0711      31 IF(ICON.NE.2) GO TO 33
0712      IF(ICOR.EQ.4) ZETAPR(1)=TR16
0713      IF(ICOR.EQ.4) ZETAPR(3)=TR26
0714      IF(ICOR.EQ.4) ZETAPR(5)=TR36
0715      33 CONTINUE
0716      IF(ICON.NE.1) GO TO 34
0717      DO 35 I=1,5,2
0718      35 ZETAPR(I)=.5*ZETAR(I)

```



```

0719      34 CONTINUE
0720      ZETAR(2)= ZETAR(1)+(RR(2)-RR1)/(RR3-RR1)*(ZETAR(3)-ZETAR(1))
0721      ZETAR(4) =ZETAR(3)+(RR(4)-RR3)/(RR5-RR3)*(ZETAR(5)-ZETAR(3))
0722      ZETAPR(2)=ZETAPR(1)+(RR(2)-RR1)/(RR3-RR1)*(ZETAPR(3)-ZETAPR(1))
0723      ZETAPR(4)=ZETAPR(3)+(RR(4)-RR3)/(RR5-RR3)*(ZETAPR(5)-ZETAPR(3))
0724      DO 7001 I=1,5
0725      7001 CONTINUE
0726      RETURN
0727      END
C
0729      FUNCTION VAURA(TH,TE,SP)
C
0730      TH=THROAT OPENING
C
0731      TF=TRAILING EDGE THICKNESS
C
0732      SP=BLADE SPACING
C
0733      ARG1=TH/SP
0734      TERM1=ATAN(SQRT(1.-(ARG1**2))/ARG1)
0735      TERM2=TERM1*180./3.14159
0736      TERM3=1.-TERM2/90.
0737      TERM4=(4.*TF/SP)*TERM3
0738      ARG2=(TH/SP)+TERM4
0739      VAURA=ATAN(SQRT(1.-(ARG2**2))/ARG2)
0740      RETURN
0741      END
C
0742      C
0743      C
0744      C
0745      FUNCTION XPO(ANG1,ANG2)
0746      COMMON,TRA/XPO1(5,8),XPO2(6,8),ALF1(8),ALF01(5),ALF02(6),
0747      *Y(10),Y1(10),Q(6),RX(30),RY(30),IR(30),Z(6),C1(4,8),C2(4,8)
0748      IF(ANG2-80.) 1,2,3
0749      1 CONTINUE
0750      DO 4 I=1,8
0751      DO 5 J=1,4
0752      5 Q(J)=C1(J,I)
0753      4 Y(I)=YC(ANG2,Q,3)
0754      GO TO 10
0755      2 CONTINUE
0756      DO 6 I=1,8
0757      6 Y(I)=XPO1(5,I)
0758      GO TO 10
0759      3 CONTINUE
0760      DO 7 I=1,8
0761      DO 8 J=1,3
0762      8 Q(J)=C2(J,I)
0763      7 Y(I)=YC(ANG2,Q,2)
0764      10 CONTINUE
0765      DO 11 I=1,7
0766      IF(ANG1.GE.ALF1(I).AND.ANG1.LE.ALF1(I+1)) GO TO 100
0767      IF(ANG1.LT.ALF1(1)) GO TO 101
0768      IF(ANG1.GT.ALF1(8)) GO TO 102
0769      11 CONTINUE
0770      100 CONTINUE
0771      XPO=Y(I)+(Y(I+1)-Y(I))/(ALF1(I+1)-ALF1(I))*(ANG1-ALF1(I))
0772      IF(ANG2.LT.40) XPO=0.09-(0.09-(XPO1(1,I)+XPO1(1,I+1))/2.)*
0773      *(ANG2-20.)/20.
0774      RETURN
0775      101 XPO=Y(1)
0776      RETURN
0777      102 XPO=Y(8)
0778      RETURN
0779      END
C
0780      C
0781      FUNCTION CSIM(V1,TO,FMME,GAM)
0782      ERRE=848.*9.80665/FMME
0783      AST=SQRT(2.*GAM/(GAM+1.))*ERRE*TO)
0784      AMACH=V1/AST
0785      IF(AMACH.LE.0.8) CSIM=1.
0786      IF(AMACH.LE.0.8) GO TO 1000
0787      IF(AMACH.LE.1.1) CSIM=1.-0.22/0.3*(AMACH-0.8)
0788      IF(AMACH.LT.1.2.AND.AMACH.GT.1.1) CSIM=0.78+0.15/0.1*(AMACH-1.1)
0789      IF(AMACH.GT.1.2) CSIM=0.92+1.5/.2*(AMACH-1.2)
0790      1000 RETURN
0791      END
C
0792      C
0793      SUBROUTINE CID(ANG1,T,DEL,CSID,PSID,PSIF,HM,DM)
0794      DIMENSION X(7),Y1(7),Y2(7)
0795      FF=1.-DEL/T/SIN(ANG1)
0796      DATA X/15.,20.,25.,30.,45.,60.,90./
0797      DATA Y1/1.06,1.1,1.17,1.225,1.63,2.1,2.45/
0798      DATA Y2/0.016,0.0315,0.049,0.072,0.156,0.260,0.4 /

```



```

0799      A=ANG1*180./3.1415
0800      DO 1 I=1,6
0801      IF(A.LE.X(I)) Y=1.+0.06*A/15.
0802      IF(A.GE.X(I).AND.A.LE.X(I+1)) Y=(Y1(I+1)-Y1(I))/(X(I+1)-X(I))*
0803      *(A-X(I))+Y1(I)
0804      IF(A.LE.X(I)) Z=Y2(I)*A/X(I)
0805      IF(A.GE.X(I).AND.A.LE.X(I+1)) Z=(Y2(I+1)-Y2(I))/(X(I+1)-X(I))*
0806      *(A-X(I))+Y2(I)
0807      1 CONTINUE
0808      IF(A.GT.X(7)) Y=1.
0809      IF(A.GT.X(7)) Z=1.
0810      CSID=1.+(Y-1.)*2.*(1.-EF)
0811      PSID=Z*4.*(1.-EF)*(1.-EF)
0812      PSIF=0.025/0.09*HM*HM/DM/DM
0813      RETURN
0814      END
0815      C
0816      FUNCTION CSIW(XPO,CSIP,T,ANG1,AH)
0817      CSIW=XPO*CSIP*T*SIN(ANG1)/AH
0818      RETURN
0819      END
0820      C
0821      FUNCTION CSIR(S,AH,V1,ANG1,UM,XP)
0822      SL=S/AH
0823      IF(SL.LE.0.4) XL=XP*0.65/.4*SL
0824      IF(SL.GT.0.4.AND.SL.LE.0.8) XL=XP*(0.65+0.45/0.4*(SL-.4))
0825      IF(SL.GT.0.8.AND.SL.LE.1.5) XL=XP*(1.1+0.04/0.7*(SL-0.8))
0826      IF(SL.GT.1.5) XL=XP*(1.5+0.6/1.7*(SL-1.5))
0827      ASC=V1*SIN(ANG1)/UM
0828      XRO=0.025+0.015/0.64*ASC*ASC
0829      IF(ASC.LT..2) XRO=.024
0830      IF(ASC.GT..95) XRO=.0475
0831      CSIR=XRO*XL
0832      RETURN
0833      END
0834      C
0835      FUNCTION ALEAK(DELBET,DM,AL,CLE,ALFA1)
0836      C1=0.82-0.075*DELBET
0837      ALEAK=C1*(DM+AL)*CLE/DM/AL/COS(ALFA1)
0838      RETURN
0839      END
0840      C
0841      C
0842      SUBROUTINE CHBFT(X,Y,N,A,M,RX,RH,R)
0843      C DESCRIPTION OF PARAMETERS:
0844      C X ARRAY OF ABSCISSAE DIMENSIONED REAL*4 X(N)
0845      C Y ARRAY OF ORDINATES DIMENSIONED REAL*4 Y(N)
0846      C N NUMBER OF SAMPLE POINTS (INTEGER)
0847      C A ARRAY OF THE OUTPUTTED POLYNOMIAL COEFFICIENTS
0848      C DIMENSIONED AT LEAST A(M+2) (REAL*4)
0849      C M ORDER OF DESIRED APPROXIMATING POLYNOMIAL
0850      C RX WORK ARRAY DIMENSIONED AT LEAST REAL*4 RX(M+2)
0851      C RH WORK ARRAY DIMENSIONED AT LEAST REAL*4 RH(M+2)
0852      C R INTEGER WORK ARRAY DIMENSIONED AT LEAST R(M+2)
0853      C
0854      C NOTE: DIVIDED DIFFERENCES AND NEWTON'S INTERPOLATING FORMULA IS
0855      C USED FOR COMPUTING THE POLYNOMIAL COEFFICIENTS.
0856      C
0857      REAL NEXTHI
0858      INTEGER RI,RJ,R(1)
0859      DIMENSION X(1),Y(1),A(1),RX(1),RH(1)
0860      MPLUS1=M+1
0861      MPLUS2=M+2
0862      PREVH=0.0
0863      C DETERMINE INDEX VECTOR FOR INITIAL REFERENCE SET
0864      R(1)=1
0865      R(MPLUS2)=N
0866      D=(N-1)/MPLUS1
0867      H=D
0868      DO 1 I=2,MPLUS1
0869      R(I)=H+1.0
0870      H=H+D
0871      2 H=-1.0
0872      C SELECT M+2 REFERENCE PAIRS AND SET ALTERNATIVE DEVIATION VECTOR
0873      DO 3 I=1,MPLUS2
0874      RJ=R(I)
0875      RX(I)=X(RI)
0876      A(I)=Y(RI)
0877      H=-H
0878      3 RH(I)=H

```



```

0879 C COMPUTE M+1 LEADING DIVIDED DIFFERENCES
0880 DO 4 J=1,MPLUS1
0881 I1=MPLUS2
0882 AI1=A(I1)
0883 RH11=RH(I1)
0884 T=MPLUS1
0885 5 DENOM=RX(I1)-RX(I-J+1)
0886 AI=A(I)
0887 RH1=RH(I)
0888 A(I1)=(AI1-AI)/DENOM
0889 RH(I1)=(RH11-RH1)/DENOM
0890 I1=I
0891 AI1=AI
0892 RH11=RH1
0893 I=I-1
0894 IF(I-J) 4,5,5
0895 4 CONTINUE
0896 C EQUATE (M+1) THE DIFFERENCE TO ZERO TO DETERMINE H
0897 H=-A(MPLUS2)/RH(MPLUS2)
0898 C WITH H KNOWN, COMBINE THE FUNCTION AND DEVIATION DIFFERENCES
0899 DO 6 I=1,MPLUS2
0900 6 A(I)=A(I)+RH(I)*H
0901 C COMPUTE POLYNOMIAL COEFFICIENTS
0902 J=M
0903 7 XJ=RX(J)
0904 I=J
0905 AI=A(I)
0906 JPLUS1=J+1
0907 DO 8 I1=JPLUS1,MPLUS1
0908 AI1=A(I1)
0909 A(I)=AI-XJ*AI1
0910 AI=AI1
0911 8 I=I1
0912 J=J-1
0913 IF(J-1) 9,7,7
0914 9 CONTINUE
0915 C IF THE REFERENCE DEVIATION IS NOT INCREASING MONOTONICALLY
0916 C THEN EXIT
0917 HMAX=ABS(H)
0918 IF(HMAX.GT.PREXH) GO TO 29
0919 A(MPLUS2)=-HMAX
0920 RETURN
0921 C FIND THE INDEX, IMAX, AND VALUE, HIMAX, OF THE LARGEST ABSOLUTE
0922 C ERROR FOR ALL SAMPLE POINTS
0923 29 A(MPLUS2)=HMAX
0924 PREXH=HMAX
0925 IMAX=R(1)
0926 HIMAX=H
0927 J=1
0928 RJ=R(J)
0929 DO 110 I=1,N
0930 IF(I.EQ.RJ) GO TO 11
0931 XI=X(I)
0932 HI=A(MPLUS1)
0933 K=M
0934 12 HI=HI*XI+A(K)
0935 K=K-1
0936 IF(K-1) 112,12,12
0937 112 HI=Y(I)
0938 ARSHI=ABS(HI)
0939 IF(ARSHI.LE.HMAX) GO TO 11
0940 HMAX=ARSHI
0941 HIMAX=HI
0942 IMAX=I
0943 GO TO 110
0944 11 IF(J.GE.MPLUS2) GO TO 110
0945 J=J+1
0946 RJ=R(J)
0947 110 CONTINUE
0948 C IF THE MAXIMUM ERROR OCCURS AT A NONREFERENCE POINT, EXCHANGE THIS
0949 C POINT WITH THE NEAREST REFERENCE POINT HAVING AN ERROR OF THE
0950 C SAME SIGN AND REPEAT
0951 IF(IMAX.EQ.R(1)) RETURN
0952 DO 14 I=2,MPLUS2
0953 IF(IMAX.LT.R(I)) GO TO 15
0954 14 CONTINUE
0955 I=MPLUS2
0956 15 NEXTHI=H
0957 IF((1-I/2)*H.NE.0) NEXTHI=-H
0958 IF(HIMAX*NEXTHI.GE.0) GO TO 115

```





```

0959     IF(IMAX.GE.R(1)) GO TO 116
0960     J1=MPLUS2
0961     J=M
0962     117 R(J1)=R(J)
0963     J1=J
0964     J=J-1
0965     IF(J-1) 118,117,117
0966     118 R(1)=IMAX
0967     GO TO 2
0968     116 IF(IMAX.LE.R(MPLUS2)) GO TO 120
0969     J=1
0970     DO 121 J1=1,MPLUS2
0971     R(J)=R(J1)
0972     121 J=J1
0973     R(MPLUS2)=IMAX
0974     GO TO 2
0975     115 R(I)=IMAX
0976     GO TO 2
0977     120 R(I-1)=IMAX
0978     GO TO 2
0979     END
0980
0981 C     SUBROUTINE TRAU1
0982     COMMON/TRA/XPO1(5,8),XPO2(6,8),ALF1(8),ALFO1(5),ALFO2(6),
0983     *Y(10),Y1(10),Q(6),RX(30),RY(30),IR(30),Z(6),C1(4,8),C2(4,8)
0984 C
0985     DO 6 I=1,8
0986     DO 7 J=1,5
0987     7 Y(J)=XPO1(J,I)
0988     DO 8 J=1,6
0989     8 Y1(J)=XPO2(J,I)
0990     CALL CHBFT(ALFO1,Y,5,Q,3,RX,RY,IR)
0991     CALL CHBFT(ALFO2,Y1,6,Z,3,RX,RY,IR)
0992     DO 12 J=1,4
0993     C1(J,I)=Q(J)
0994     12 C2(J,I)=Z(J)
0995     6 CONTINUE
0996     RETURN
0997     END
0998 C
0999     SUBROUTINE TRAU2 (ANG1,ANGO,V1,TO,EMME,GAM,T,DEZ,HM,DM,CSIP,S,UM,
1000     *CL,RPRO,R2,R3,YCL,RTOT)
1001     CSIP=1
1002     R=XPO(ANG1,ANGO)
1003     R1=CSIM(V1,TO,EMME,GAM)
1004     ANGZ=ANG1*3.1415/180
1005     CALL CID(ANGZ,T,DEZ,CSID,PSID,PSIF,HM,DM)
1006     R2=CSIW(R,CSIP,T,ANGZ,HM)
1007     R3=CSIR(S,HM,V1,ANGZ,UM,CSIP)
1008     RPRO=R*CSIP*R1*CSID+PSIF+PSID
1009     IF(CL.LE.0.) YCL=0
1010     IF(CL.LE.0.) GO TO 1000
1011     DEL=3.1416-(ANGO+ANG1)*3.1416/180
1012     ALF1=1.5708-ANGZ
1013     YCL=ALEAK(DEL,DM,HM,CL,ALF1)
1014     1000 RTOT=RPRO+R2+R3
1015 C
1016     RETURN
1017     END
1018     FUNCTION YC(XBAR,Q,M)
1019     DIMENSION Q(6)
1020     YC=0
1021     IF(XBAR.EQ.0.) YC=Q(1)
1022     IF(XBAR.EQ.0.) GO TO 10
1023
1024     M1=M+1
1025     DO 1 I=1,M1
1026     1 YC=YC+Q(I)*XBAR**(I-1)
1027     10 CONTINUE
1028     1000 RETURN
1029     END

```



&SHORT T=00003 IS ON CR00025 USING 00024 BLKS R=0000

```
0001 FTN4,L
0002 PROGRAM SHORT(5)
0003 DIMENSION INAM(3)
0004 DIMENSION NAME(3)
0005 C
0006 C
0007 COMMON/ABA/BA17,BLEX
0008 COMMON/CUR/COSL(10)
0009 COMMON/TOL/TOL1,TOL2,TOL3,TOL4
0010 COMMON/TR5/TRAS
0011 COMMON/GAS/CP,GAM,EMME,ERF,EXP1,EXP2,VIS2,VIS3
0012 COMMON/COZ/ICOR,ICOZ,INC,IAI,ICL,IAN,ICON
0013 COMMON/MAC/IN
0014 COMMON/IWI/IND,INZ,IWR
0015 COMMON/AUS/XCL
0016 COMMON/CSS/CJ,G,Q1
0017 COMMON/VAR1/RC(10),RSOLD2,RSOLD3,RSOLD4,ASFO,RSFO,RRFO,ARFO,
0018 *RR(10),RROLD2,RROLD3,RROLD4,CV,CK,VA1(10),DALF(10),DBET(10),
0019 *ASF,AMS,R1(20)
0020 COMMON/VAR2/B6(20),ZR,ZS,ARF,R2(20),PR,AMR,VU1(10)
0021 COMMON/VAR3/PTE(10),RS1,RS3,RS5,T2(10)
0022 COMMON/VAR4/BR1,BR2,RR3,RR1,RR3,RR5,UA2(10)
0023 COMMON/VAR5/PRAT1(10),RINCI(10),ALFA11(10),BETA11(10),ZETA1(10),
0024 *V2(10),ALFA22(10),BETA22(10)
0025 COMMON/VAR6/PT2(10),TT2(10),PT1(10),DELH(10),ALFA2(10),VU2(10),
0026 *WR2(10),T2S(10),T2IS(10)
0027 COMMON/VAR7/TTIS(5),RETAT(5),ETAT(5),ETAI(10),ETAS(10),ETAR(10),
0028 *RSTAR(10),AKIS(10),PSIR(10)
0029 COMMON/VAR8/DR1(10),AMU1(10),AMU2(10),BETET(10),PRAT1T(10),AMR2(
0030 *10),YS(10),X1(10),AREA1(10),ZETAPS(10),WPER1(10),YR(10),X2(10)
0031 COMMON/VAR9/ZETAR(10),ZETAPR(10),AS(10),AR(10),SI1(10),SI2(10),
0032 *S1(10),DSDX1(10),WI1(10),HE(10)
0033 COMMON/VAR10/WU1(10),DHEDX(10),DSDX2(10),RI1(10),RI2(10),
0034 *RI3(10),RI4(10),RI(10),SR1(10),SR2(10)
0035 COMMON/VAR11/YOLD(10),AA(10),SR(10),PRAT2(10),WPER2(10),
0036 *DWDX(10),T1IS(10),PRAT3(10),SS(10),ALFA(10)
0037 COMMON/VAR12/BETA(10),DELK(10),WPER0(10),ZETAS(10),ZETAR1(20),
0038 *ZETAR3(20),ZETAR5(20),R1(20),A1(20),T10(20)
0039 COMMON/VAR13/ST1(20),IRR(20),R2(20),A2(20),RINC(20),DR(10),
0040 *BETO(10),STALII(10),AREA2(10),VR1(10)
0041 COMMON/VAR14/WLBM,PRATS,OMEG
0042 COMMON/AL1/ALFA1(10),V1(10),TTO,RPM,RS(10),SI,TNI,H,D,CI,T1(10),
0043 *P1(10),TO,TEI,ALI,BESP,XX,ANG20,AMS1(10),S,TN,C,TE,AL,SO,TNO,
0044 *CO,TEO,U(10),D1I,D10,D2I,D20,ANG2I,ALFAX,TI,T,PTO,A10,AMC
0045 COMMON/AL2/BETA2(10),BETA1(10),BETA0(10),W2(10),TTE(10),U2(10),
0046 *SIR,TNIR,HR,DZ,CIR,TIPC,SZ,TNR,CR,SOR,TNOR,COR,ALIR,ALR,ALOR,
0047 *P2(10),WU2(10),W1(10),TEIR,TER,TEOR,D1IR,D1OR,BETAZ,BETA1,ANM,
0048 *TIR,TR,TOR,STALI(10)
0049 COMMON/ARE/REE
0050 COMMON/TRA/XPO1(5,8),XPO2(6,8),ALF1(8),ALF01(5),ALF02(6),
0051 *Y(10),Y1(10),Q(6),RX(30),RY(30),IR(30),Z(6),C1(4,8),C2(4,8)
0052 DATA INAM /2HSH,2HOR,2HT /
0053 DATA NAME /2HPA,2HRT,2H2 /
0054 CALL TRAU1
0055 XX=1.25
0056 RLEX=0.15
0057 XCL=1.35
0058 C
0059 C
0060 BESP=(1.+(GAM-1.)/2.*.64)**(-GAM/(GAM-1.))
0061 C
0062 C
0063 C
0064 C
0065 C *****OPERATING CONDITIONS*****
0066 PTO=38.22
0067 TIO=626.18
0068 RPM=12000.
0069 PR=2.6
0070 C *****
0071 C
0072 C
0073 C *****INITIAL APPROXIMATIONS*****
0074 AMC=.2247
0075 AMS=.9
0076 AMR=.7
0077 VA1(3)=262.58
0078 VA2(3)=262.58
```



```

0079 C *****
0080 C
0081 C
0082 C *****SPECIAL INPUT DATA*****
0083 TOL1=.01
0084 TOL2=.01
0085 TOL3=.01
0086 TOL4=.01
0087 C
0088 IND=0
0089 INZ=0
0090 IWR=0
0091 ICOR=4
0092 IAI=0
0093 C
0094 IAN=2
0095 ICL=0
0096 IINC=1
0097 ICOZ=6
0098 ICON=3
0099 C
0100 *****
0101 C
0102 C *****TURBINE GEOMETRY*****
0103 A1(1)=.2126
0104 A1(2)=.22145
0105 A1(3)=.23035
0106 A1(4)=.23925
0107 A1(5)=.24815
0108 A1(6)=.25705
0109 A1(7)=.26595
0110 A1(8)=.27485
0111 A1(9)=.28375
0112 A1(10)=.2926
0113 C
0114 A2(1)=.1912
0115 A2(2)=.20305
0116 A2(3)=.21495
0117 A2(4)=.22685
0118 A2(5)=.23875
0119 A2(6)=.25065
0120 A2(7)=.26255
0121 A2(8)=.27445
0122 A2(9)=.28635
0123 A2(10)=.2983
0124 C
0125 AL=1.088
0126 ALI=1.088
0127 ALO=1.088
0128 C
0129 C=1.003
0130 CI=1.003
0131 CO=1.003
0132 C
0133 E=2.8065
0134 EI=2.8065
0135 EO=2.8065
0136 C
0137 T=.2252
0138 TI=.2252
0139 TO=.2252
0140 C
0141 TE=.03
0142 TEI=.03
0143 TEO=.03
0144 C
0145 TN=.0186
0146 TNI=.0186
0147 TNO=.0186
0148 C
0149 ALR=1.088
0150 ALIR=1.088
0151 ALOR=1.088
0152 C
0153 CR=1.003
0154 CIR=1.003
0155 COR=1.003
0156 C
0157 FR=2.45
0158 FIR=2.45

```



```

0159      EOR=2.45
0160      C
0161      TR=.2252
0162      TIR=.2252
0163      TOR=.2252
0164      C
0165      TER=.03
0166      TEIR=.03
0167      TEOR=.03
0168      C
0169      TNR=.0186
0170      TNIR=.0186
0171      TNOR=.0186
0172      C
0173      RC(1)=2.764
0174      RC(5)=3.627
0175      C
0176      RS(1)=2.764
0177      RS(5)=3.627
0178      C
0179      RR(1)=2.693
0180      RR(5)=3.837
0181      C
0182      CV=.885
0183      CK=5.0
0184      TIPG=.01
0185      ZS=31.
0186      ZR=32.
0187      C *****
0188      C
0189      C
0190      RC(2)=SQRT(RC(5)*RC(5)/4.+3./4.*RC(1)*RC(1))
0191      RC(3)=SQRT(RC(5)*RC(5)/2.+RC(1)*RC(1)/2.)
0192      RC(4)=SQRT(3./4.*RC(5)*RC(5)+RC(1)*RC(1)/4.)
0193      RS(2)=SQRT(RS(5)*RS(5)/4.+RS(1)*RS(1)/4.*3.)
0194      RS(3)=(RS(1)+RS(5))/2.
0195      RS(4)=SQRT(((RS(5)**2)*.75)+((RS(1)**2)/4.))
0196      RR(2)=SQRT(RR(5)*RR(5)/4.+3./4.*RR(1)*RR(1))
0197      RR(3)=(RR(1)+RR(5))/2.
0198      RR(4)=SQRT(RR(5)*RR(5)*3./4.+RR(1)*RR(1)/4.)
0199      DO 3300 I=1,10
0200      A=I
0201      R1(I)=RS(1)+(A-1.)/9.*(RS(5)-RS(1))
0202      R2(I)=RR(1)+(A-1.)/9.*(RR(5)-RR(1))
0203      3300 CONTINUE
0204      OI=A1(1)
0205      NO=A1(10)
0206      OIR=A2(1)
0207      OOR=A2(10)
0208      DO 3711 I=1,10
0209      IF(RS(3).LE.R1(I)) GO TO 3712
0210      3711 CONTINUE
0211      3712 CONTINUE
0212      I=I-1
0213      O=A1(I)+(A1(I+1)-A1(I))*(RS(3)-R1(I))/(R1(I+1)-R1(I))
0214      DO 3713 I=1,10
0215      IF(RR(3).LE.R2(I)) GO TO 3714
0216      3713 CONTINUE
0217      3714 CONTINUE
0218      I=I-1
0219      OR=A2(I)+(A2(I+1)-A2(I))*(RR(3)-R2(I))/(R2(I+1)-R2(I))
0220      H=RS(5)-RS(1)
0221      D=2.*RS(3)
0222      S=2.*3.1416*RS(3)/ZS
0223      SI=2.*3.1416*RS(1)/ZS
0224      SO=2.*3.1416*RS(5)/ZS
0225      S7=2.*3.1416*RR(3)/ZR
0226      SIR=2.*3.1416*RS(1)/ZR
0227      SOR=2.*3.1416*RS(5)/ZR
0228      DZ=2.*RR(3)
0229      HR=RR(5)-RR(1)
0230      C
0231      C STATOR OUTLET ANGLES BY VAVRA METHOD
0232      C
0233      ALFA1(3)=VAVRA(O,TN,S)
0234      ANG2I =VAVRA(OI,TNI,SI)
0235      ANG2O =VAVRA(OO,TNO,SO)
0236      C
0237      DALF(1)=ANG2I-ALFA1(3)
0238      DALF(3)=0.

```





```

0239      DALF(5)=ANG20-ALFA1(3)
0240
0241      ROTOR OUTLET ANGLES BY VAURA METHOD
0242
0243      BETA2(3)=-1.*VAURA(OOR,TNR,SZ)
0244      BETAI   =-1.*VAURA(OIR,TNIR,SIR)
0245      BETAZ   =-1.*VAURA(OOR,TNOR,SOR)
0246
0247
0248      DBET(1)=BETAI-BETA2(3)
0249      DBET(3)=0.
0250      DBET(5)=BETAZ-BETA2(3)
0251      X1(I)=RS(I)/RS(3)
0252      X2(I)=RR(I)/RR(3)
0253      RROLD2=RR(2)
0254      RROLD3=RR(3)
0255      RROLD4=RR(4)
0256      RSOLD2=RS(2)
0257      RSOLD3=RS(3)
0258      RSOLD4=RS(4)
0259      RS1=RS(1)
0260      RS3=RS(3)
0261      RS5=RS(5)
0262      RR1=RR(1)
0263      RR3=RR(3)
0264      RR5=RR(5)
0265      CALL CHRFT(R1,A1,10,B1,4,T10,ST1,IRR)
0266      CALL CHRFT(R2,A2,10,B2,4,T10,ST1,IRR)
0267      ASF=B1(1)+B1(2)*RR(3)+B1(3)*RS(3)**2+B1(4)*RS(3)**3+B1(5)*RS(3)**4
0268      ARF=B2(1)+B2(2)*RR(3)+B2(3)*RR(3)**2+B2(4)*RR(3)**3+B2(5)*RR(3)**4
0269      ASF=.2526
0270      ARF=.2447
0271      RSF=RS(3)
0272      ASFO=ASF
0273      RSFO=RSF
0274      RRF=RR(3)
0275      RRFO=RRF
0276      ARFO=ARF
0277      C      INPUT PRINTING
0278
0279      WRITE(6,671)
0280      671 FORMAT(1H1,/,60X,12HINPUT PRINTS//40X,50H      R1      A1
0281      *      R2      A2      /)
0282
0283      DO 72 I=1,10
0284      73 WRITE(6,73) R1(I),A1(I),R2(I),A2(I)
0285      73 FORMAT(40X,F10.3,F10.4,10X,F10.3,F10.4)
0286      72 CONTINUE
0287      WRITE(6,74) ZS,ZR,TIPC,CV,CK
0288      74 FORMAT(/45X,25HNUMBER OF STATOR BLADES =,F8.0/45X,25HNUMBER OF ROT
0289      *OR BLADES =,F8.0/45X,25HROTOR TIP CLEARANCE =,F8.4/45X,25HAXI
0290      *AL DISTANCE L =,F8.2/45X,25HCURVATURE FACTOR K =,F8.2/
0291      *//55X,16HBLADING GEOMETRY//)
0292      WRITE(6,75)
0293      75 FORMAT(/30X,70H      C      E      T      TE      TN
0294      *      AL      R      /)
0295      WRITE(6,76) CI,EI,TI,TEI,TNI,ALI,RS(1),C,E,T,TE,TN,AL,RS(3),CO,EO,
0296      *TO,TEO,TNO,ALO,RS(5)
0297      76 FORMAT(30X,7F10.4/22X,6HSTATOR,2X,7F10.4/30X,7F10.4/)
0298      77 FORMAT(30X,7F10.4/22X,6HROTOR,2X,7F10.4/30X,7F10.4/)
0299      WRITE(6,77) CIR,EIR,TIP,TEIR,TNIR,ALIR,RR(1),CR,ER,TR,TER,TNR,ALR,
0300      *RR(3),COR,EOR,TOR,TEOR,TNOR,ALOR,RR(5)
0301      WRITE(6,78)
0302      78 FORMAT(/40X,52HALL DIMENSIONS INDICATED IN THIS TABLE ARE IN INCHE
0303      *S/)
0304      WRITE(6,79) ICOR,IAT,IAN,ICOZ,IINC,ICL,ICON
0305      79 FORMAT(////,40X,27HCORRELATION SYSTEM      ICOR =,15/61X,6HIAT =,15/
0306      *61X,6HIAN =,15/61X,6HICIZ =,15/61X,6HIINC =,15/61X,6HICL =,15/6
0307      *1X,6HICON =,15)
0308      WRITE(6,81) CP,EMF,GAM,VIS2,VIS3
0309      81 FORMAT(/20X,91HGAS PROPERTIES      CP      MOLECULAR MASS
0310      *GAMM      VISCOSITY (1)      VISCOSITY (2)/38X,10H(RTU/LB F),32X,13
0311      *H(LBM /SEC FT),4X,13H(LBM /SEC FT)//36X,F9.3,5X,F10.3,9X,F7.3,2E15
0312      *.3/)
0313      C      CALL EXEC(8,NAME)
0314      END

```



SPART2 T=00004 IS ON CR00025 USING 00030 BLKS R=0000

```
0001 FTN4,I
0002 PROGRAM PART2(5)
0003 DIMENSION NAME(3)
0004 DIMENSION NAMR(3)
0005 COMMON/ARA/BA17,BLEX
0006 COMMON/CUR/COSL(10)
0007 COMMON/TOL/TOL1,TOL2,TOL3,TOL4
0008 COMMON/TR5/TRAS
0009 COMMON/GAS/CP,GAM,EMME,ERRE,FXP1,EXP2,VIS2,VIS3
0010 COMMON/COZ/TCOR,ICDZ,IINC,IAI,ICL,IAN,ICON
0011 COMMON/MAC/IN
0012 COMMON/IWT/IND,INZ,IWR
0013 COMMON/AUS/XCL
0014 COMMON/CSS/CJ,G,Q1
0015 COMMON/VAR1/RC(10),RSOLD2,RSOLD3,RSOLD4,ASFO,RSFO,RRFO,ARFO,
0016 *RR(10),RROLD2,RROLD3,RROLD4,CV,CK,VA1(10),DALF(10),DBET(10),
0017 *AFF,AMS,R1(20)
0018 COMMON/VAR2/R6(20),ZR,ZS,ARF,R2(20),PR,AMR,VU1(10)
0019 COMMON/VAR3/PTE(10),RS1,RS3,RS5,T2(10)
0020 COMMON/VAR4/BK1,BR2,BR3,RR1,RR3,RR5,VA2(10)
0021 COMMON/VAR5/PRAT1(10),RINCI(10),ALFA11(10),BETA11(10),ZETA1(10),
0022 *V2(10),ALFA22(10),BETA22(10)
0023 COMMON/VAR6/PT2(10),TT2(10),PT1(10),DELH(10),ALFA2(10),VU2(10),
0024 *WR2(10),T2S(10),T2TS(10)
0025 COMMON/VAR7/TTIS(5),BETAT(5),ETAT(5),ETAI(10),ETAS(10),ETAR(10),
0026 *RSTAR(10),AKIS(10),PSIR(10)
0027 COMMON/VAR8/DR1(10),AMW1(10),AMV2(10),RETET(10),PRAT1T(10),
0028 *AMR2(10),YS(10),X1(10),AREA1(10),ZETAPS(10),WPER1(10),YR(10),
0029 *X2(10)
0030 COMMON/VAR9/ZETAR(10),ZETAPR(10),AS(10),AR(10),SI1(10),SI2(10),
0031 *S1(10),DSDX1(10),WI1(10),HE(10)
0032 COMMON/VAR10/WU1(10),DHEDX(10),DSDX2(10),RI1(10),RI2(10),
0033 *RI3(10),RI4(10),RI(10),SR1(10),SR2(10)
0034 COMMON/VAR11/YOLD(10),AA(10),SR(10),PRAT2(10),WPER2(10),
0035 *DWDX(10),T1IS(10),PRAT3(10),SS(10),ALFA(10)
0036 COMMON/VAR12/BETA(10),DELR(10),WPERO(10),ZETAS(10),ZETAR1(20),
0037 *ZETAR3(20),ZETARS(20),R1(20),A1(20),T1(20)
0038 COMMON/VAR13/ST1(20),IRR(20),R2(20),A2(20),RINC(20),DR(10),
0039 *RETO(10),STALII(10),AREA2(10),VR1(10)
0040 COMMON/VAR14/WLRM,PRATS,OMEG
0041 COMMON/AL1/ALFA1(10),V1(10),TTO,RPM,RS(10),SI,TNI,H,D,CI,T1(10),
0042 *P1(10),TO,TFI,ALI,BFSP,XX,ANGP0,AMS1(10),S,TN,C,TF,AL,SO,TNO,
0043 *CO,TEO,U(10),D11,D10,D21,D20,ANG21,ALFAX,TI,T,PTO,AIO,AMC
0044 COMMON/AL2/BETA2(10),BETA1(10),BETA0(10),W2(10),TTE(10),U2(10),
0045 *SIR,TNIR,HR,DZ,CIR,TIPC,SZ,TNR,CR,SOR,TNCR,COR,ALTR,ALR,ALOR,
0046 *P2(10),W02(10),W1(10),TEIR,TER,TEOR,D1IR,D1OR,BETAZ,BETA1,ANM,
0047 *TIR,TR,TOR,STALI(10)
0048 COMMON/ARE/REE
0049 COMMON/TRA/XP01(5,8),XP02(6,8),ALF1(8),ALF01(5),ALF02(6),
0050 *Y(10),Y1(10),Q(6),RX(30),RY(30),IR(30),Z(6),C1(4,8),C2(4,8)
0051 DATA NAME /2HPA,2HRT,2H2 /
0052
0053 DATA NAMR/2HPA,2HRT,2H3 /
0054 DO 67 I=1,5
0055 U(I)=RPM*3.14159/30./12.*RS(I)
0056 DR(I)=0.
0057 DELK(I)=0.
0058 ZETAS(I)=.10
0059 ZETAR(I)=.15
0060 ZETAPS(I)=0.05
0061 ZETAPR(I)=0.05
0062 COSL(I)=1.0
0063 YS(I)=1.0
0064 67 YR(I)=1.0
0065 N9=0.
0066 750 NS=0
0067 N9=N9+1
0068 7750 CONTINUE
0069 100 RS(2)=RSOLD2
0070 RS(3)=RSOLD3
0071 DO 530 I=1,5
0072 530 X1(I)=RS(I)/RS(3)
0073 ASF=ASFO
0074 RSF=RSFO
0075 FS1=1.0
0076 FS2=1.0
0077 CALL CHAN (TTO,AMC,PTO,RC,WLRM,WCHAN,WPERO)
0078 NS=0
```



```

0079      810 DO 801 K=1,15
0080      CALL STATR (ALFA1,X1,TTO,PTO,AMS,T1,P1,U1,VA1,ST1,ST2,YS,S1,
0081      *DSDX1,VU1,PRAT1,T1IS,SS,DALF,RSF,DELR,CV,CK,ZETAPS,RS,RS1,RS3,
0082      *RSS,ZETAS,DR,ZETA1,AMS1,NS,VR1)
0083      CALL ALOS1(ZETAS,ZETAPS)
0084      DO 120 J=1,5
0085      PTE(I)=PTO
0086      120 TTE(I)=TTO
0087      CALL FLOWR (PRAT1,ZETAPS,X1,WI1,PTE,PTO,TTE,TTO,ASF,ZS,RSF,ASF,
0088      *ZR,RSF,1,WCHAN,VA1,WPER1,CODE,WLBM,B1,RS,TIPC,AREA1)
0089      IF(IN.EQ.1) AMC=AMC-.01
0090      IF(IN.EQ.1) GO TO 7750
0091      IF(CODE-20.) 801,802,801
0092      801 CONTINUE
0093      802 CONTINUE
0094      FC1=1.
0095      FC2=FC1**2
0096      ARF=ARFO
0097      RRF=RROLD3
0098      RR(2)=RROLD2
0099      RR(3)=RRF
0100      RR(4)=RROLD4
0101      DO 71 I=1,5
0102      AMS1(I)=U1(I)/SQRT(GAM*ERREX*GT1(I))
0103      X2(I)=RR(I)/RR(3)
0104      71 CONTINUE
0105      CALL ROT01 (VU1,VA1,RPM,U,BETA1,HE,TTE,PTE,X2,P1,T1,W1,WU1,X1,
0106      *RS,ZETAR,ZETAPR,RR,DHEDX,DSDX1,S1,U2,OMFG,BR1,BR2,BR3,FS1,FS2,
0107      *ZETAR,B6,RS1,RS3,RSS,BETO,STALII,RINCI,VR1)
0108      CODE=1.
0109      IMACC=0
0110      201 DO 200 K=1,14
0111      CALL ROT02 (BETA2,HE,DHEDX,DSDX1,DSDX2,VA2,WU2,W2,VU2,V2,X2,U2,
0112      *YR,ZETAR,RI1,RI2,RI3,RI4,RI,SR1,SR2,AA,SR,TTE,PTE,T2,P2,PRAT2,
0113      *T2S,INDS,IBET,RRF,DELR,CV,CK,DR,RR,RR1,RR3,RR5,NS,WR2)
0114      CALL ALOS2(ZETAR,ZETAPR)
0115      IF (INDS-1) 310,320,310
0116      320 WRITE (6,36) ((AA(I),I=1,5)
0117      WRITE(6,36) ((AA(I),ZFTAR(I),VA2(I)),I=1,5)
0118      36 FORMAT(35H ENTROPY INDETERMINATE,PRINT AA 1-5,5E12.4/,25X,10HZETAR
0119      * 1-5,5E12.4/25X,10H VA2 1-5,5E12.4/)
0120      IND=1
0121      310 CALL FLOWR (PRAT2,ZETAPR,X2,WI1,PTE,PTO,TTE,TTO,ASF,ZS,RSF,ARF,
0122      *ZR,RRF,2,WCHAN,VA2,WPER2,CODE,WLBM,B2,RR,TIPC,AREA2)
0123
0124      IF(IN.EQ.1) AMC=AMC-.01
0125      IF(IN.EQ.1) GO TO 7750
0126      200 CONTINUE
0127      130 CONTINUE
0128      IMACC=IMACC+1
0129      IF(IMACC,GE.10) GO TO 220
0130      4322 FORMAT(/20H LOOP IN SLINE ROT//5E10.3)
0131      IF(CODE-40.) 201,220,201
0132      5000 CONTINUE
0133      220 DO 221 I=1,5
0134      DELR(I)=RS(I)-(RC(I)+RR(I))/2.
0135      DR(I)=RC(I)-RR(I)
0136      221 COSL(I)=SQRT(CV*CV/(DR(I)**2+CV*CV))
0137      NS=1
0138      880 DO 881 K=1,15
0139      CALL ALOS1(ZETAS,ZETAPS)
0140      CALL STATR (ALFA1,X1,TTO,PTO,AMS,T1,P1,U1,VA1,ST1,ST2,YS,S1,
0141      *DSDX1,VU1,PRAT1,T1IS,SS,DALF,RSF,DELR,CV,CK,ZETAPS,RS,RS1,RS3,
0142      *RSS,ZETAS,DR,ZETA1,AMS1,NS,VR1)
0143      DO 860 I=1,5
0144      PTE(I)=PTO
0145      860 TTE(I)=TTO
0146      CALL FLOWR (PRAT1,ZETAPS,X1,WI1,PTE,PTO,TTE,TTO,ASF,ZS,RSF,ASF,
0147      *ZR,RSF,1,WCHAN,VA1,WPER1,CODE,WLBM,B1,RS,TIPC,AREA1)
0148      IF(IN.EQ.1) AMC=AMC-.01
0149      IF(IN.EQ.1) GO TO 7750
0150      IF(CODE-20.) 881,822,881
0151      881 CONTINUE
0152      822 CONTINUE
0153      861 CALL ROT01 (VU1,VA1,RPM,U,BETA1,HE,TTE,PTE,X2,P1,T1,W1,WU1,X1,
0154      *RS,ZETAR,ZETAPR,RR,DHEDX,DSDX1,S1,U2,OMFG,BR1,BR2,BR3,FS1,FS2,
0155      *ZETAR,B6,RS1,RS3,RSS,BETO,STALII,RINC,VR1)
0156      CODE=1.
0157      894 DO 896 K=1,10
0158      CALL ALOS2 (ZETAR,ZETAPR)

```



```

0159      CALL ROTOP (BETA2,HE,DHDX,DSDX1,DSDX2,VA2,WU2,W2,UU2,U2,X2,U2,
0160      *YR,ZETAR,RI1,RI2,RI3,RI4,RI,SR1,SR2,AA,AF,TTE,PTE,T2,P2,PRAT2,
0161      *T2S,INDS,DEBT,RRF,DELR,CV,CK,DR,RR,RR1,RR3,RR5,NS,WR2)
0162      IF(INDS=1) 895,320,895
0163      895 CALL FLOWR(PRA12,ZETAPR,X2,WI1,PTE,PTO,TTE,TT0,ASF,ZS,RSF,ARF,ZR,
0164      *RRF,2,WCHAN,VA2,WFER2,CODE,WLBM,R2,RR,TIPC,AREA2)
0165      IF(IN.EQ.1) AMC=AMC-.01
0166      IF(IN.EQ.1) GO TO 7750
0167      IF(CODE=20.) 896,897,896
0168      896 CONTINUE
0169      897 CONTINUE
0170      226 DO 227 I=1,5
0171      227 PRAT3(I)=PTO/P2(I)
0172      IND=0
0173      PRATS=(PRAT3(1)+2.*(PRAT3(2)+PRAT3(3)+PRAT3(4))+PRAT3(5))/8.
0174      WRITE(1,265) PRATS
0175      265 FORMAT(IX,'COMPUTED PRESSURE RATIO=',F6.3)
0176      DIFF=ABS(PR-PRATS)
0177      TAL=TOL3*PR
0178      IF(TAL-DIFF) 920,910,910
0179      910 N11=0
0180      GO TO 223
0181      920 CONTINUE
0182      710 IF(PR-PRATS) 712,712,714
0183      712 AMC=AMC-DIFF/18.
0184      GO TO 750
0185      714 AMC=AMC+DIFF/18.
0186      GO TO 750
0187      223 CONTINUE
0188      CALL EXEC(8,NAMR)
0189      END

```





APART3 T=00004 IS ON CR00025 USING 00042 BLKS R=0000

```
0001 FTN4,L
0002 PROGRAM PART3(S)
0003 DIMENSION NAME(3)
0004 DIMENSION NAMR(3)
0005 COMMON/ABA/BA17,BLEX
0006 COMMON/CUR/COSL(10)
0007 COMMON/TOL/TOL1,TOL2,TOL3,TOL4
0008 COMMON/TR5/TRAS
0009 COMMON/GAS/CP,GAM,FMME,ERRE,EXP1,EXP2,VIS2,VIS3
0010 COMMON/COZ/ICOR,ICOZ,IINC,IAI,ICL,IAN,ICON
0011 COMMON/MAC/IN
0012 COMMON/IWI/IND,INZ,IWR
0013 COMMON/AUS/XCL
0014 COMMON/CSS/CJ,G,Q1
0015 COMMON/VAR1/RC(10),RSOLD2,RSOLD3,RSOLD4,ASFO,RSFO,RRFO,ARFO,
0016 *RR(10),RROLD2,RROLD3,RROLD4,CV,CK,VA1(10),DALF(10),DBET(10),
0017 *ASF,AMS,R1(20)
0018 COMMON/VAR2/B6(20),ZR,ZS,ARF,B2(20),PR,AMR,VU1(10)
0019 COMMON/VAR3/PTE(10),RS1,RS3,RS5,T2(10)
0020 COMMON/VAR4/BR1,BR2,RR3,RR1,RR3,RR5,VA2(10)
0021 COMMON/VAR5/PRA1(10),KINCI(10),ALFA1(10),BETA1(10),ZETA1(10),
0022 *V2(10),ALFA2(10),BETA2(10)
0023 COMMON/VAR6/PT2(10),TT2(10),PT1(10),DELH(10),ALFA2(10),VU2(10),
0024 *WR2(10),T25(10),T2IS(10)
0025 COMMON/VAR7/TTIS(5),BETAT(5),ETAT(5),ETAI(10),ETAS(10),ETAR(10),
0026 *RSTAR(10),AKIS(10),PSTR(10)
0027 COMMON/VAR8/DR1(10),AMW1(10),AMW2(10),BFTET(10),PRAT1T(10),
0028 *AMR2(10),YS(10),X1(10),ARFA1(10),ZETAPS(10),WPER1(10),YR(10),
0029 *X2(10)
0030 COMMON/VAR9/ZETAR(10),ZETAPR(10),AS(10),AR(10),SI1(10),SI2(10),
0031 *S1(10),DSDX1(10),WI1(10),HE(10)
0032 COMMON/VAR10/WU1(10),DHFDX(10),DSDX2(10),RI1(10),RI2(10),
0033 *RI3(10),RI4(10),RI(10),SR1(10),SR2(10)
0034 COMMON/VAR11/YOLD(10),AA(10),SR(10),PRAT2(10),WPER2(10),
0035 *DWDX(10),TIIS(10),PRAT3(10),SS(10),ALFA(10)
0036 COMMON/VAR12/BETA(10),DELR(10),WPERO(10),ZETAS(10),ZETAR1(20),
0037 *ZETAR3(20),ZETARS(20),R1(20),A1(20),T10(20)
0038 COMMON/VAR13/ST1(20),IRR(20),R2(20),A2(20),RINC(20),DR(10),
0039 *RFO(10),STALII(10),ARFA2(10),UR1(10)
0040 COMMON/VAR14/WLRM,PRATS,OMEG
0041 COMMON/AL1/ALFA1(10),V1(10),TTO,RPM,RS(10),SI,TNT,H,D,CI,T1(10),
0042 *P1(10),TO,TEI,ALI,BESP,XX,ANG20,AMS1(10),S,TN,C,TE,AL,SO,TNO,
0043 *CO,TEO,U(10),D1I,D10,D2I,D20,ANG2I,ALFAX,T1,T,PTO,ALO,AMC
0044 COMMON/AL2/BETA2(10),BETA1(10),BETA0(10),W2(10),TTE(10),U2(10),
0045 *SIR,TNIR,HR,DZ,CIR,TIPC,SZ,TNR,CR,SOR,TNOR,COR,ALIK,ALR,ALOR,
0046 *P2(10),W2(10),W1(10),TEIR,TER,TEOR,D1TR,D1OR,BETAZ,BETA1,ANM,
0047 *TIR,TR,TOR,STAL1(10)
0048 COMMON/ARE/REE
0049 COMMON/TRA/XP01(5,8),XP02(6,8),ALF1(8),ALF01(5),ALF02(6),
0050 *Y(10),Y1(10),Q(6),RX(30),RY(30),IR(30),Z(6),C1(4,8),C2(4,8)
0051 DATA NAME /2HPA,2HRT,2H2 /
0052
0053 DATA NAMR/2HPA,2HRT,2H3 /
0054
0055 999 FORMAT(1H1)
0056 WRITE(6,999)
0057 WRITE(6,401)
0058 401 FORMAT(///27X,' SET PAGE RPM TOTAL/STATIC INLET
0059 *TOTAL INLET TOTAL')
0060 WRITE(6,402)
0061 402 FORMAT( 27X,67HNUMBER NUMBER PRESSURE RATIO PRESSU
0062 *RE TEMPERATURE)
0063 403 FORMAT(72X,5H(P5I),7X,8H(DEG. R)/)
0064 J=1
0065 IS=1
0066 WRITE(6,405)J,IS,RPM,PR,PTO,TTO
0067 405 FORMAT(27X,13,I8,F11.1,F14.3,F14.3,F15.2/)
0068 WRITE(6,404)
0069 404 FORMAT(//57X21H STATOR EXIT SOLUTION//)
0070 WRITE(6,406)
0071 406 FORMAT(1X,'STREAM RADIAL X=K/RM RADIAL BLADE Y=VA
0072 */VAM BLADE LOSS ZETA* FLOW RATE')
0073 WRITE(6,407)
0074 407 FORMAT(1X,109H LINE POSITION SHIFT OPENING
0075 * EFFICIENCY COEFFICIENT CONTINUITY FRACTION /)
0076 WRITE(6,411)
0077 411 FORMAT(12X,4H(IN),13X,4H(IN),5X,4H(IN))
0078 DD 408. T=1,S
```



```

0079 PRAT1(I)=1./PRAT1(I)
0080 ALFA11(I)=ALFA1(I)*57.3
0081 BETA11(I)=BETA1(I)*57.3
0082 ALFA2(I)=ATAN(UU2(I)/VA2(I))
0083 V2(I)=VAP(I)/COS(ALFA2(I))
0084 V2(I)=SQRT(V2(I)*V2(I)+WR2(I)*WR2(I))
0085 ALFA22(I)=ALFA2(I)*57.3
0086 BETA22(I)=BETA2(I)*57.3
0087 DELH(I)=(U(I)*UU1(I)-U2(I)*UU2(I))/(G*CJ)
0088 TT2(I)=TTO-DELH(I)/CP
0089 PT2(I)=P2(I)*(TT2(I)/T2(I))**EXP1
0090 PT1(I)=P1(I)*(TTO/T1(I))**EXP1
0091 T2IS(I)=TTO*(P2(I)/PTO)**FXP2
0092 T2S(I)=TTE(I)*(P2(I)/PTE(I))**EXP2
0093 TTIS(I)=TTO*(PT2(I)/PTO)**EXP2
0094 BETAT(I)=PTO/PT2(I)
0095 ETAT(I)=(TTO-TT2(I))/(TTO-TTIS(I))
0096 ETAI(I)=(TTO-TT2(I))/(TTO-T2IS(I))
0097 ETAS(I)=(TTO-T1(I))/(TTO-T1IS(I))
0098 ETAR(I)=(TTE(I)-T2(I))/(TTE(I)-T2S(I))
0099 RSTAR(I)=(T1IS(I)-T2IS(I))/(TTO-T2IS(I))
0100 AKIS(I)=2.*G*CJ*CP*(TTO-T2IS(I))/U(I)**2
0101 PSJK(I)=SQRT(ETAR(I))
0102 DR1(I)=RC(I)-RS(I)
0103 AMW1(I)=W1(I)/SQRT(GAM*ERRE*G*T1(I))
0104 AMS1(I)=V1(I)/SQRT(GAM*ERRE*G*T1(I))
0105 AMV2(I)=V2(I)/SQRT(GAM*ERRE*G*T2(I))
0106 AMR2(I)=W2(I)/SQRT(GAM*ERRE*G*T2(I))
0107 BETET(I)=PTE(I)/P2(I)
0108 PRAT1T(I)=PTO/PT1(I)
0109 408 WRITE(6,409) I,KS(I),X1(I),DR1(I),AREA1(I),YS(I),ETAS(I),ZETA1(I),
0110 *ZETAPS(I),WPER1(I)
0111 DELH(10)=0.
0112 DO 240 I=1,4
0113 L=I+1
0114 240 DELH(10)=DELH(10)+.5*(WPER2(L)-WPER2(I))*(DELH(L)+DELH(I))
0115 HP=DELH(10)*CJ*WLRM/550.
0116 AMOM=HP*550./OMEG
0117 THETA=SQRT(TTO/518.4)
0118 DELTA=PTO/14.7
0119 HP1=HP/(THETA*DELTA)
0120 AMOM1=AMOM/DELTA
0121 RPM=RPM/THETA
0122 WLRM1=WLRM*THETA/DELTA
0123 ETAS=(ETAI(1)+ETAI(5)+2.*(ETAI(2)+ETAI(3)+ETAI(4)))/8.
0124 BETA6=(BETAT(1)+BETAT(5)+2.*(BETAT(2)+BETAT(3)+BETAT(4)))/8.
0125 ETA6=(ETAT(1)+ETAT(5)+2.*(ETAT(2)+ETAT(3)+ETAT(4)))/8.
0126 AKISS=(AKIS(1)+AKIS(5)+2.*(AKIS(2)+AKIS(3)+AKIS(4)))/8.
0127 RSTAR5=(RSTAR(1)+RSTAR(5)+2.*(RSTAR(2)+RSTAR(3)+RSTAR(4)))/8.
0128 409 FORMAT(1X,I4,F12.3,F10.3,F9.4,F9.4,F11.4,F11.4,F14.4,F13.4,F14.4)
0129 WRITE(6,412)
0130 412 FORMAT(///22X,23HABSOLUTE VELOCITY (FPS),27X,23HRELATIVE VELOCITY
0131 *(FPS)///)
0132 413 FORMAT(1X,6HSTREAM,2X,2(50H AXIAL RADIAL TANGENTIAL OVER
0133 *ALL ),7H WHEEL )
0134 WRITE(6,413)
0135 WRITE(6,414)
0136 414 FORMAT(1X,6H LINE 2(50HCOMPONENT COMPONENT COMPONENT VE
0137 *LOCITY ),8HVELOCITY//)
0138 DO 415 I=1,5
0139 415 WRITE(6,416) I,VA1(I),VR1(I),UU1(I),V1(I),VA1(I),VR1(I),WU1(I),W1(
0140 *I),U(I)
0141 416 FORMAT(15,2X,2(F8.2,3F12.2,6X),F8.2)
0142 WRITE(6,418)
0143 418 FORMAT(///7X,113H MACH NUMBER FLOW ANGLE
0144 * TEMPERATURE PRESSURE PRESSURE)
0145 WRITE(6,419)
0146 419 FORMAT( 7X,113H (DEG)
0147 * (DEG. R) (PSI) RATIO /)
0148 WRITE(6,492)
0149 492 FORMAT( 7H STREAM )
0150 WRITE(6,420)
0151 420 FORMAT(7H LINE ,2(24H ABSOLUTE RELATIVE ),2(24H TOTAL
0152 * STATIC ),24H TOT/TOT TOT/STA /)
0153 DO 422 I=1,5
0154 422 WRITE(6,421) I,AMS1(I),AMW1(I),ALFA11(I),BETA11(I),TTO,T1(I),PT1(I)
0155 * ,P1(I),PRAT1T(I),PRAT1(I)
0156 421 FORMAT(14,3X,2F10.2,4X,2F10.2,4X,2F10.3,4X,F11.4,F10.4)
0157 WRITE(6,999)
0158 WRITE(6,401)

```



```

0159      WRITE(6,402)
0160      WRITE(6,403)
0161 452  FORMAT(/57X,21H  ROTOR EXIT SOLUTION///)
0162      IS=2
0163      WRITE(6,405) J,IS,RPM,PR,PTO,TT0
0164      WRITE(6,452)
0165      WRITE(6,406)
0166      WRITE(6,407)
0167      DO 423 I=1,5
0168 423  WRITE(6,409) I,RR(I),X2(I),DR(I),AREA2(I),YR(I),ETAR(I),ZETAR(I),
0169      *ZETAPR(I),WPER2(I)
0170      WRITE(6,412)
0171      WRITE(6,413)
0172      WRITE(6,414)
0173      DO 424 I=1,5
0174 424  WRITE(6,416) I,VA2(I),WR2(I),VU2(I),V2(I),VA2(I),WR2(I),WU2(I),W2(I)
0175      *),U2(I)
0176      WRITE(6,418)
0177      WRITE(6,419)
0178      WRITE(6,492)
0179      WRITE(6,420)
0180      DO 425 I=1,5
0181 425  WRITE(6,421) I,AMV2(I),AMR2(I),ALFA22(I),BETA22(I),TT2(I),T2(I),
0182      *PT2(I),P2(I),BETAT(I),PRAT3(I)
0183      WRITE(6,491)
0184 491  FORMAT(///)
0185      WRITE(6,426)
0186 426  FORMAT(7H STREAM, 41H EQUIVALENT EQUIVALENT EQUIV/STATIC)
0187 427  FORMAT(7H LINE , 38H TEMPERATURE INLET PRESSURE PRESSURE)
0188 428  FORMAT( 7X, 38H PRESSURE PRESSURE PRESSURE)
0189 429  FORMAT( 7X, 22H (DEG. R) (PSI) (PSI) RATIO)
0190      WRITE(6,427)
0191      WRITE(6,428)
0192      WRITE(6,429)
0193      DO 430 I=1,5
0194 430  WRITE(6,431) I,ITE(I),PTE(I),BETET(I)
0195 431  FORMAT(I4,F13.2,F15.3,F11.1)
0196      WRITE(6,999)
0197      WRITE(6,401)
0198      WRITE(6,402)
0199      WRITE(6,403)
0200      IS=3
0201      WRITE(6,405) J,IS,RPM,PR,PTO,TT0
0202      WRITE(6,441)
0203 441  FORMAT(/45X,31H OVERALL TURBINE CHARACTERISTICS///)
0204      WRITE(6,442)
0205 442  FORMAT(102H STREAM PRESSURE RATIO EFFICIENCY
0206      * HEAD BLADE/JET THEORETICAL )
0207      WRITE(6,443)
0208 443  FORMAT(102H LINE TOT/STA TOT/TOT TOT/STA TOT/TOT
0209      * COEFFICIENT SPEED RATIO DEGREE OF REACTION /)
0210      DO 444 I=1,5
0211      BLAJE=1./SQRT(AKIS(I))
0212 444  WRITE(6,445) I,PRAT3(I),BETAT(I),ETAI(I),ETAT(I),AKIS(I),BLAJE,RST
0213      *AR(I)
0214 445  FORMAT(IS,F14.4,F11.4,F11.4,F13.4,F12.4,F15.4,F16.4)
0215      WRITE(6,446)
0216 446  FORMAT(/53X,24H MASS AVERAGED QUANTITIES///)
0217 447  FORMAT(52X,13H HORSE POWER =,F10.2,3X,4H(HP))
0218 448  FORMAT(52X,13H MOMENT =,F10.2,3X,7H(FT-LB))
0219 449  FORMAT(52X,13H FLOW RATE =,F10.2,3X,9H(LB/SEC)///)
0220 461  FORMAT(43X,22H REFERRED RPM =,F10.2)
0221 462  FORMAT(43X,22H REFERRED HORSE POWER =,F10.2,3X,4H(HP))
0222 463  FORMAT(43X,22H REFERRED MOMENT =,F10.2,3X,7H(FT-LB))
0223 464  FORMAT(43X,22H REFERRED FLOW RATE =,F10.2,3X,9H(LB/SEC)///)
0224 465  FORMAT(40X,25H TOTAL/STATIC EFFICIENCY =,F10.4)
0225 466  FORMAT(40X,25H TOTAL/TOTAL EFFICIENCY =,F10.4)
0226 467  FORMAT(36X,29H TOTAL/STATIC PRESSURE RATIO =,F10.4)
0227 468  FORMAT(36X,29H TOTAL/TOTAL PRESSURE RATIO =,F10.4//)
0228 469  FORMAT(34X,31H HEAD COEFFICIENT =,F10.4)
0229 471  FORMAT(34X,31H THEORETICAL DEGREE OF REACTION =,F10.4)
0230 472  FORMAT(34X,31H BLADE/TFT SPEED RATIO =,F10.4)
0231 473  FORMAT(34X,31H MACH NUMBER AT STATION 0 =,F10.4)
0232      WRITE(6,447) HP
0233      WRITE(6,448) AMOM
0234      WRITE(6,449) WLEM
0235      WRITE(6,461) RPM1
0236      WRITE(6,462) HP1
0237      WRITE(6,463) AMOM1
0238      WRITE(6,464) WLEM1

```



```
0239 WRITE(6,465) ETA5
0240 WRITE(6,466) ETA6
0241 WRITE(6,467) PRATS
0242 WRITE(6,468) BETA6
0243 WRITE(6,469) AKISS
0244 BLAJFS=1./SQRT(AKISS)
0245 WRITE(6,472) BLAJFS
0246 WRITE(6,471) RSTARS
0247 WRITE(6,473) AMC
0248 IF(INZ-1) 400,930,930
0249 930 IF(N11-1) 400,400,400
0250 400 CONTINUE
0251 END
```





## LIST OF REFERENCES

1. Vavra, M.H., Axial Turbine Design Data, Report 1174VA1, M.H. Vavra, (Consultant), Pebble Beach, CA., 1974.
2. Macchi, E., Computer Program for Prediction of Axial-Flow Turbine Performance, NPS-57MA70081A, August 1970.
3. Eckert, R.H. Performance Analysis and Initial Tests of a Transonic Turbine Test Rig, AE Thesis, Naval Postgraduate School, Monterey, CA., 1966.
4. Harrison, G.H., An Analysis of Single Stage Axial-Flow Turbine Performance Using Three Dimensional Calculating Methods, AE Thesis, Naval Postgraduate School, Monterey, CA., 1967.
5. Vavra, M.H., Aerothermodynamics and Flow in Turbomachines, John Wiley and Sons, N.Y., Chapter 16, 1960.
6. Ainley, D.G. and Mathieson, G.C.R., A Method of Performance Estimation for Axial-Flow Turbines, Aeronautical Research Council Reports and Memoranda Number 2974, 1957.
7. Traupel, W., Thermische Turbomaschinen, Springer-Verlag, Berlin/Göttingen/Heidelberg, 1962.
8. Dunham, J and Came, P.M., Improvements to the Ainley-Mathieson Method of Turbine Performance Prediction, ASME Paper 70-6T-2, 1970.
9. Balje, O.E. and Binsley, R.L., Axial Turbine Performance Evaluation, Part A-Loss-Geometry Relationships, Journal of Engineering for Power, Transactions of the ASME, 1968.
10. Lonherr, F.K. and Carter, A.F., Correlations of Turbine Blade Total Pressure Loss Coefficients Derived from Achievable Stage Efficiency Data, ASME Paper 68-FE-51, 1968.
11. Geopfarth, R.N., Introductory Guide for Users of RTE-IV, TPL Technical Note 79-01, June 1979.
12. Yahyawi, M., TPL Computer User Guide-1. Operating the Computer to Write and Run a Fortran Program, TPL Technical Note 80-04, August 1980.



13. E. Macchi private communication to Lt. R. Cirone,  
December 1980.
14. Vavra, M.H., Design Report of Hybrid Compressor and  
Associated Test Rig, NPS-57VA 73071A, July 1973.



INITIAL DISTRIBUTION LIST

	No. Copies
1. Defense Technical Information Center Cameron Station Alexandria, Virginia 22314	2
2. Library, Code 0142 Naval Postgraduate School Monterey, California	2
3. Department Chairman, Code 69 Department of Mechanical Engineering Naval Postgraduate School Monterey, California 93940	2
4. Department Chairman, Code 67 Department of Aeronautics Naval Postgraduate School Monterey, California 93940	1
5. Dr. R. P. Shreeve, Code 67Sf Department of Aeronautics Naval Postgraduate School Monterey, California	1
6. Professor Paul F. Pucci, Code 69Pc Department of Mechanical Engineering Naval Postgraduate School Monterey, California 93940	1
7. Dr. E. Macchi Istituto de Macchine Plitecnico Milano, Italy	1
8. Turbopropulsion Laboratory Code 67 Naval Postgraduate School Monterey, California 93940	10
9. LT R. Cirone, USN 32 Pace Drive North Babylon, N.Y. 11703	1



10. Dr. Gerhard Heiche 1  
Research Administrator  
Code 310A  
Naval Air Systems Command  
Navy Department  
Washington, DC 20360
11. Mr. Karl H. Guttman 1  
Code 330C  
Naval Air Systems Command  
Navy Department  
Washington, DC 20360
12. Dr. A.D. Wood 1  
Office of Naval Research  
Eastern/Central Regional Office  
666 Summer Street  
Boston, MA 02210
13. Commanding Officer 1  
Naval Air Propulsion Test Center  
Attn: Mr. Vernon Lubosky  
Trenton, N.J. 08628









192395

Thesis  
C47897  
c.1

Cirone

Computer evaluation  
of the on-and-off-  
design performance of  
an axial air turbine.

192395

Thesis  
C47897  
c.1

Cirone

Computer evaluation  
of the on-and-off-  
design performance of  
an axial air turbine.

Computer evaluation of the on-and-off de

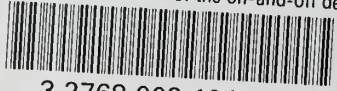

3 2768 002 10449 9  
DUDLEY KNOX LIBRARY